

Renault  
Group

# IMPLEMENTATION GUIDE OF RENAULT GROUP MULTI-BRAND SITES

Edition v1 • January 2025

# Contents

<b>1</b>	<b>Introduction</b>	<b>3</b>
<b>2</b>	<b>Surroundings and customer parking</b>	<b>10</b>
<b>3</b>	<b>Facades of showrooms</b>	<b>34</b>
<b>4</b>	<b>Showrooms</b>	<b>50</b>
<b>5</b>	<b>Common areas</b>	<b>76</b>
<b>6</b>	<b>After-sales service</b>	<b>116</b>
<b>7</b>	<b>24/7 customer services</b>	<b>131</b>
<b>8</b>	<b>renew</b>	<b>166</b>
<b>9</b>	<b>Renault Pro+</b>	<b>183</b>
<b>10</b>	<b>Back-office areas</b>	<b>194</b>
<b>11</b>	<b>Renault Dacia Alpine multi-brand sites</b>	<b>202</b>

# 1

## INTRODUCTION

## 1.1 Preamble

**The challenge of multi-branding is crucial for Renault Group brands, which must, more than ever, offer a more efficient customer relationship, develop new services and demonstrate their commitment to respecting the environment.**

This document defines the implementation rules to be respected within Renault Group multi-brand sites, when the implementation of separate buildings by brand is not possible.

**The identity standards of the Renault & Dacia brand network must be applied** in all situations.

The application rules must allow the deployment of multi-brand sites while:

- **offering customers the most readable paths for a consistent customer experience** regardless of the nature of the site,
- **ensuring a balanced presence of the brands,**
- **respecting the identity of the brands** thanks to clear separation rules and the strict organization of cases of cohabitation within common areas.

## 1.2 Limits of the current approach

- 1 Outdoor exhibition areas occupy too much space in front of the showrooms.  
**First priority should be given to customer parking and the ease of reading the façade.**
- 2 Cohabitation of brand universes in common areas disrupts customer perception.  
**The brand universes must be reinforced near the products on display.**
- 3 Integration of new mobility services is a major challenge for the years to come.  
**Their implementation leads to a redistribution of outdoor surfaces.**
- 4 Identity systems were designed independently of each other.  
**The simple juxtaposition of brands on the façades and in the showrooms shows its limits.**
- 5 Pooling of functions is a necessary way to reduce costs.  
**It cannot be done by simply reallocating surfaces in the Renault part.**

### 1.3 Overview of a Renault Group multi-brand site



# 1.4 Key elements of a Renault Group multi-brand site



Customer parking on the main facade



Balanced and harmonious facades



renew & UV offers visible from the outskirts of the site



Dedicated showrooms to the universes of brands



Highly visible spaces shared by brands



24/7 services perfectly integrated into the site

## 1.5 Fundamental rules to remember

- 1 Site is identified by the use of the signage systems of the different brands.**
- 2 Customer car parks are dedicated to each of the brands,** clearly separated from each other.  
As an option, a customer car park shared by the different brands is possible.
- 3 Facades of the showrooms are identified by the signage of each of the brands,** separated by a white vertical zone.
- 4 Each showroom has a dedicated entrance.**
- 5 Delivery of vehicles is done in an exclusive space** dedicated to the Renault and Dacia brands only.
- 6 Waiting lounge is exclusive to the Renault and Dacia brands.**
- 7 Workshop bays of the Renault Dacia after-sales facade are identified by the brand signage.**  
Workshop bays dedicated to brands outside the Renault Group are strictly separated.
- 8 After-sales area (and its 24/7 services) are exclusive** to customers of Renault and Dacia brands.
- 9 Multi-brand service reception is exclusive** to the Renault and Dacia brands.
- 10 Renew and UV outdoor exhibitions** are integrated into the general plan.



## 1.6 Reference documents

### GENERAL PRINCIPLE

Specific components to the different brands and their methods of application in the different formats of points of sale are not presented in this guide, the purpose of which is to describe the conditions for cohabitation of brand universes within the Renault Group multi-brand sites.

### THE DIFFERENT BRAND DOCUMENTS

In order to discover or learn more about the rules and standards to be applied to a multi-brand point of sale, a set of documents describes the components specific to the different brands and their terms of use.

- The architectural guidelines group together in a single document the different components present on the facades and the interior design methods.
- The renew and Renault Pro+ sites have a specific architectural guideline.
- The specifications present all the technical and aesthetic requirements useful for the manufacture of each of the components.

All these documents are available on:  
<https://brandstores.renault.com>



Standardization documents and technical specifications for Renault sites



Standardization documents and technical specifications for Dacia sites



Standardization documents and technical specifications for Alpine sites



Standardization documents and technical specifications for Mobilize sites

# 2

## SURROUNDINGS AND CUSTOMER PARKING AREAS

2.1

PRESIGNAGE

## 2.1.1 Fundamentals

### **Generic implementation rule**

Presignage of Renault Dacia multi-brand sites use common supports available in different formats.

### **Don't**

It is recommended not to implement dedicated supports to each brand in order to minimize insertion into the environment.

## 2.1.2 Presignage of Renault Group multi-brand sites



### PRINCIPLES

Pre-signage panels of Renault Group multi-brand sites include the signatures of the different brands presented in a balanced manner.

The directional information is personalized for each situation.

They appear in neutral Renault Group typography.

Different formats are available to meet the implementation cases covered by strict regulations.

- 1 Multi-brand site with 2 brands.
- 2 Multi-brand site with 3 brands.

## 2.1.3 Not allowed

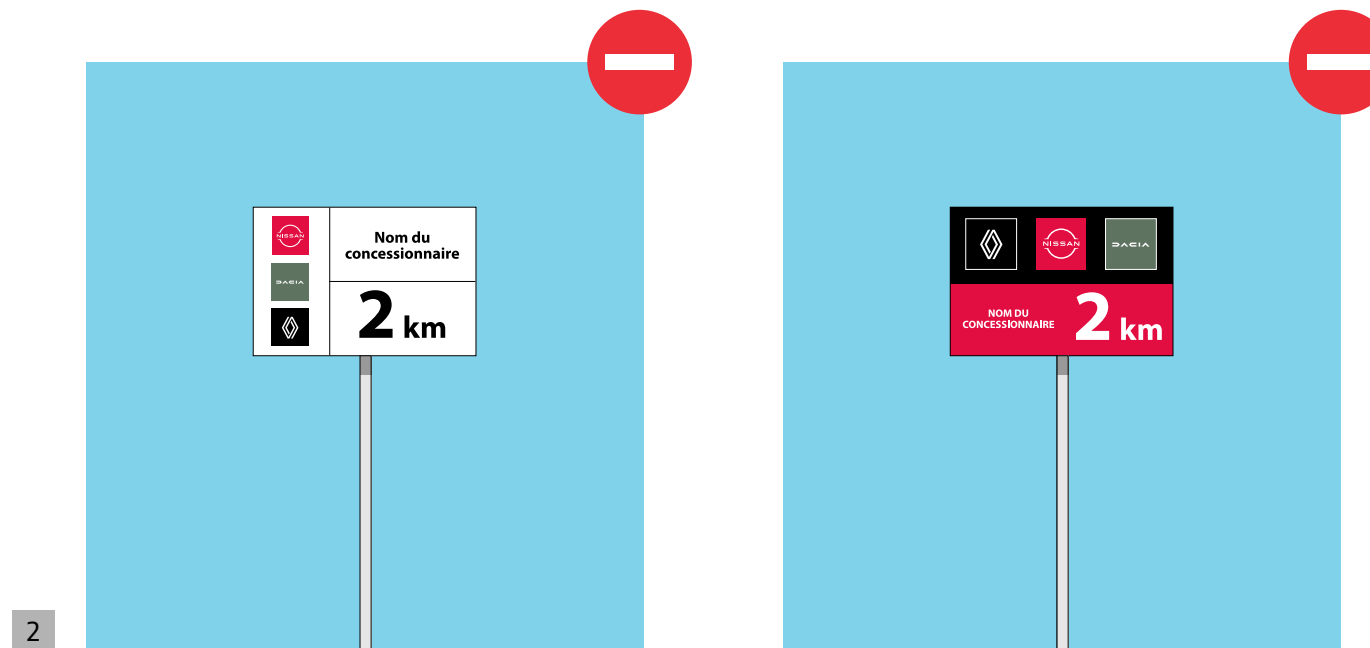
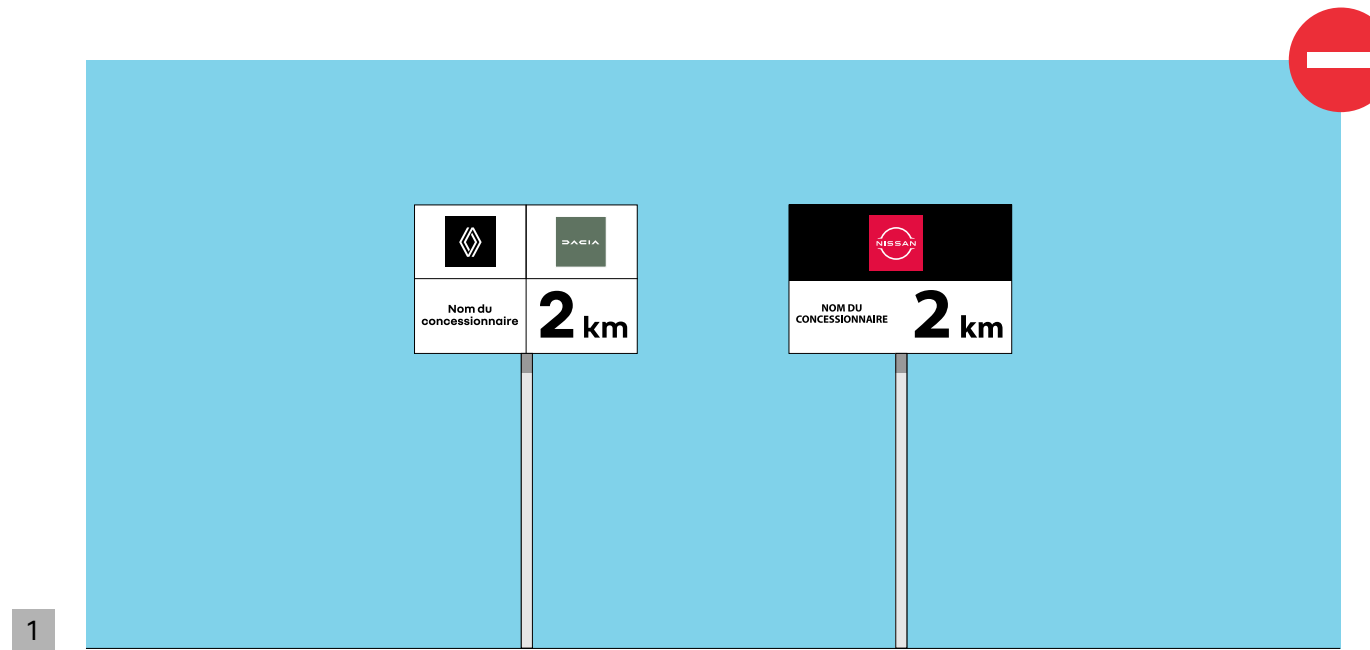

### MAIN PROHIBITIONS

- 1 Cohabitation of 2 pre-signage panels containing the different brand identities.
- 2 Change in the proportions of graphic elements.
- 3 Mixing of brand identity codes on the same panel.

# 2.2

## FLAGS AND TOTEMS

## 2.2.1 Fundamentals

### **Generic implementation rule**

On a Renault Dacia multi-brand site, the flags of the 2 brands are arranged separately in groups of 3 or 5 on either side of the site.

The totems or signs on masts are specific to each brand. They are installed in front of the entrance to the respective showrooms.

### **Don't**

In the dealership network, it is forbidden to use multi-brand signs on masts reserved for the R2 sales network.



## 2.2.2 Flags of Renault Group multi-brand sites

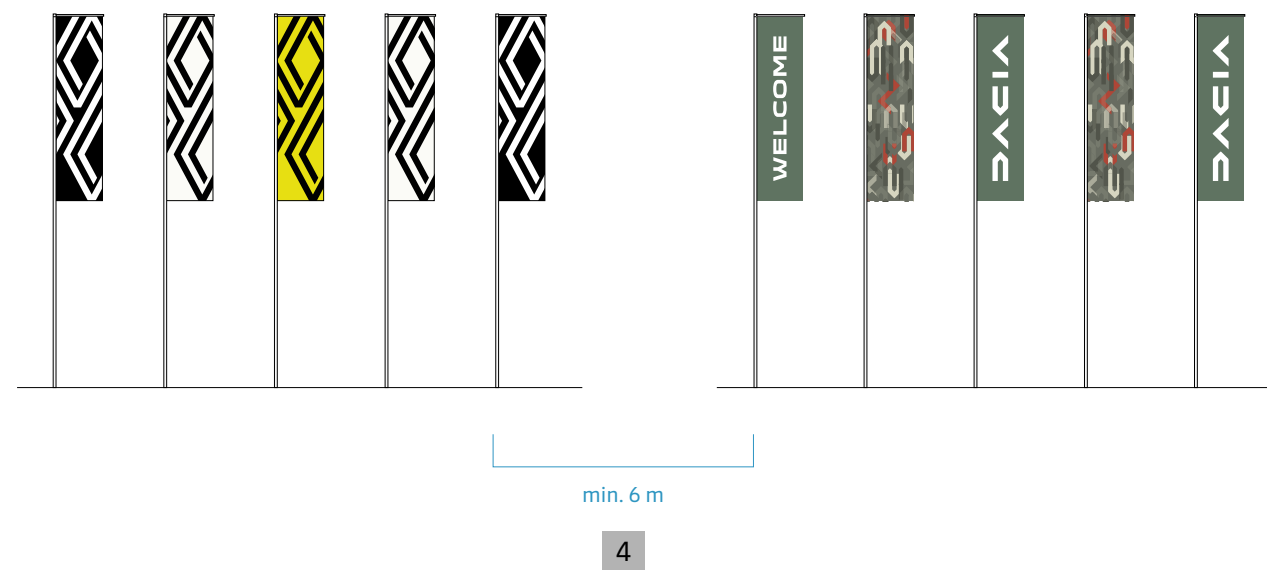
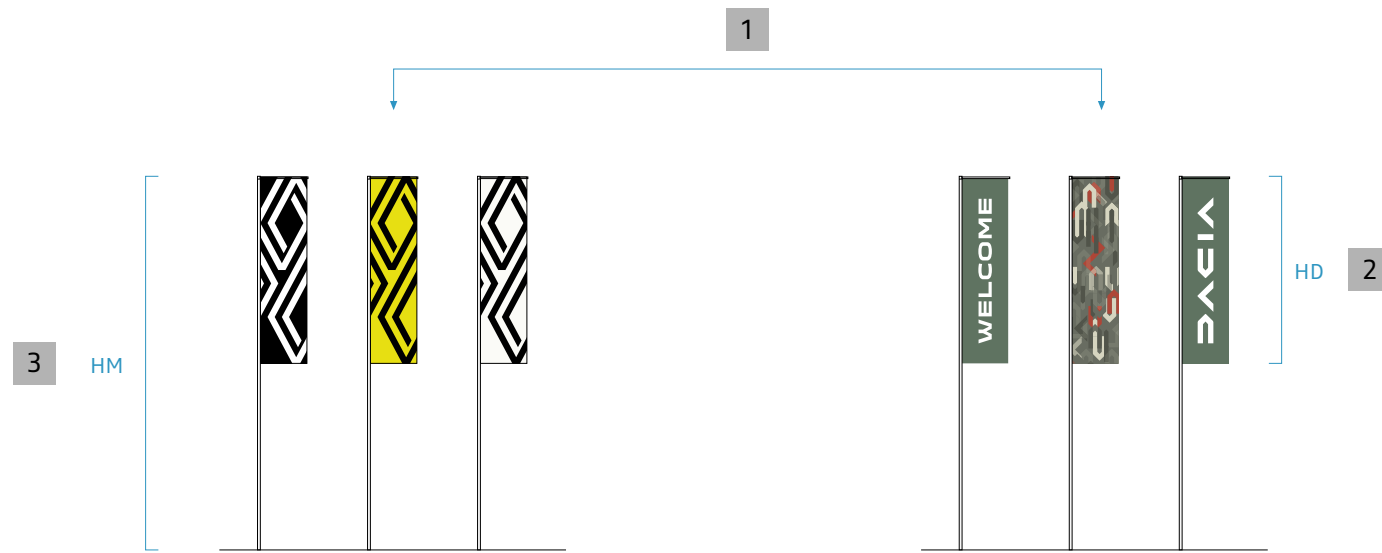

### PRINCIPLES

- 1 Number of flags is identical for each of the brands present on the site.  
The flags of each brand are presented in groups of 3 or 5.
- 2 Dimensions of the flags are the same for each of the brands.
- 3 Heights of the masts are the same for each of the brands.

## 2.2.3 Implementation principles in a multi-brand site

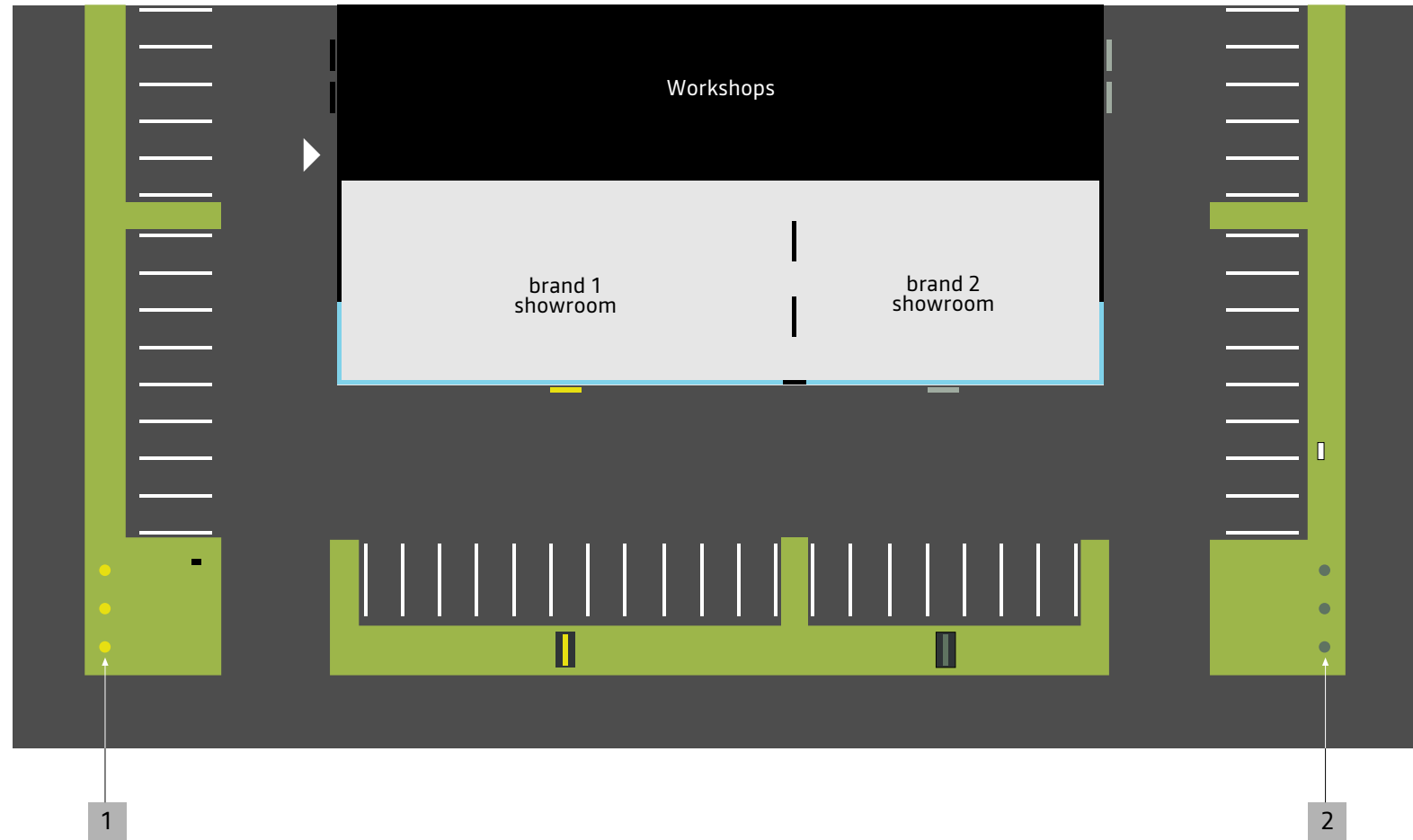

### PRINCIPLES

- 1 Flags of brand 1 are implanted next to the dedicated showroom to this brand.
- 2 Flags of brand 2 are implanted next to the dedicated showroom to this brand.

## 2.2.4 Flag grouping rules

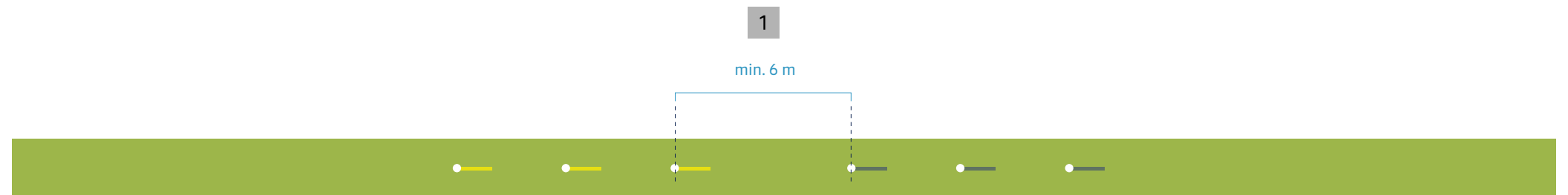
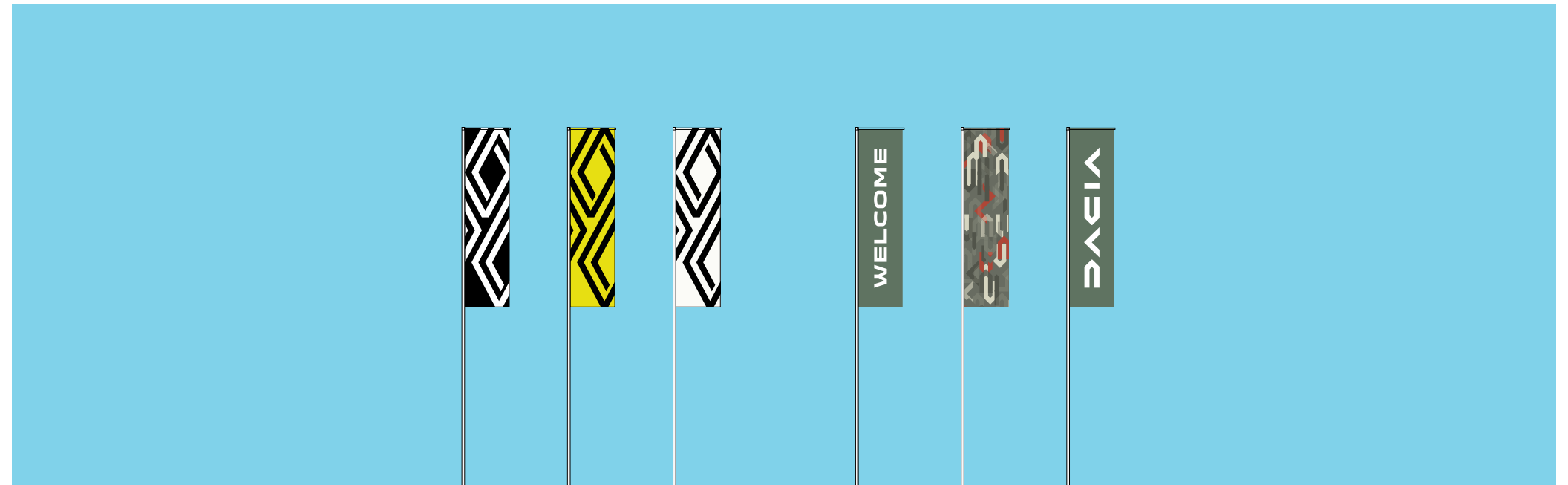

### SPECIAL CASE

When groups of flags cannot be placed on either side of the building, it is possible to place them in a line.

- 1 Groups of flags of Renault Group brands are separated by at least 6 m.

## 2.2.5 SPECIAL CASES & DON'T

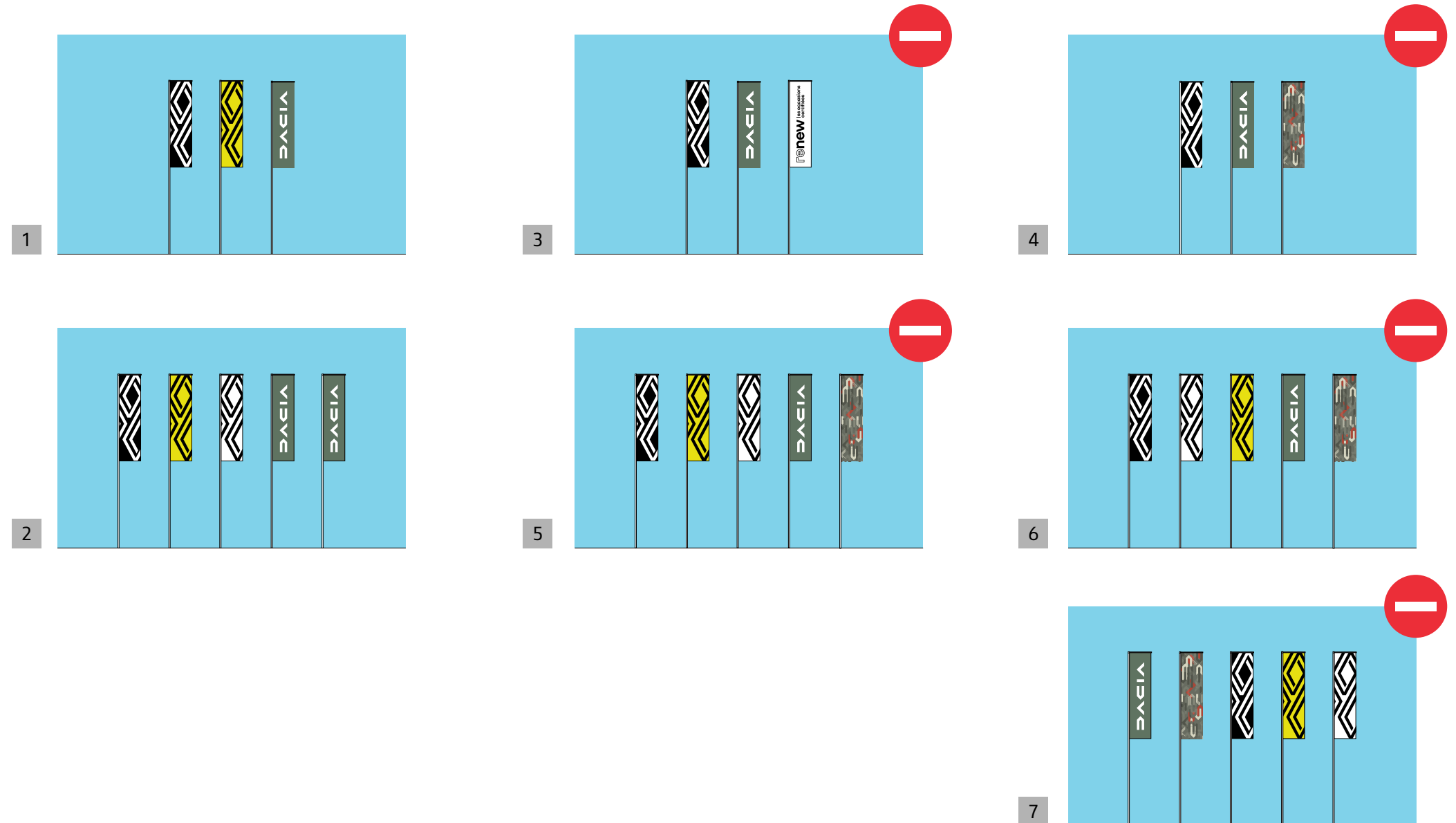

### SPECIAL CASES

When it is not possible to install separate groups of Renault and Dacia flags, it will be possible to mix the flags according to the diagrams shown opposite.

- 1 Mixed group of 3 flags.
- 2 Mixed group of 5 flags.

### DON'T

- 3 Associate a renew flag with the Renault and Dacia flags.
- 4 Associate 2 Dacia flags with a single Renault flag.
- 5 Use a Dacia "pattern" flag within the multi-brand flag group.
- 6 Use a Dacia "pattern" flag within the multi-brand flag group and change the order of the Renault flags.
- 7 Invert the positions of the Renault and Dacia flags in the multi-brand flag group.

## 2.2.6 Totems

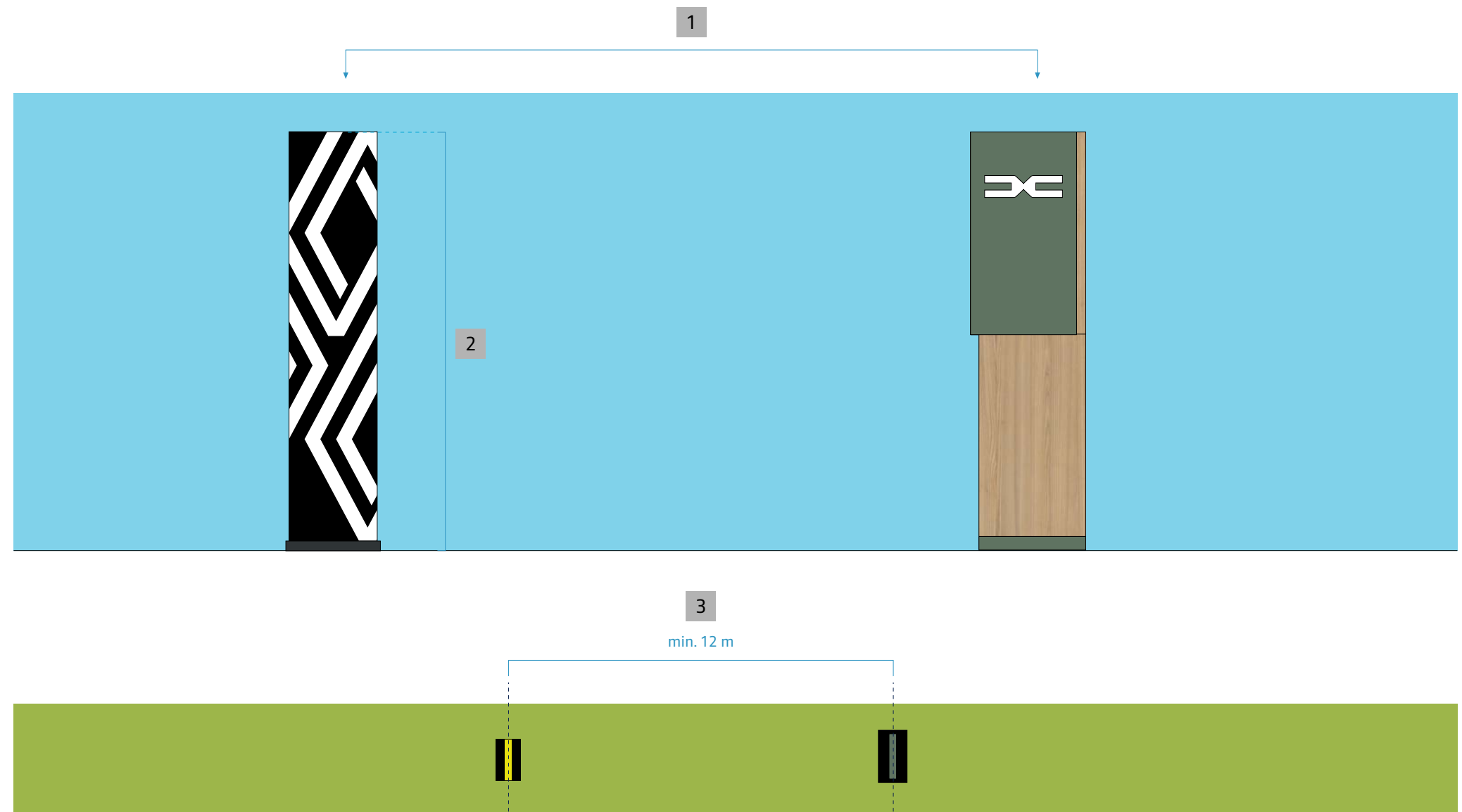

### PRINCIPLES

- 1 The totem of each brand is installed in front of the dedicated showroom.
- 2 The totems of the different brands have a similar size and impact.
- 3 The minimum distance to be respected between 2 totems is 12 m.

## 2.2.7 Flag insignias on mast

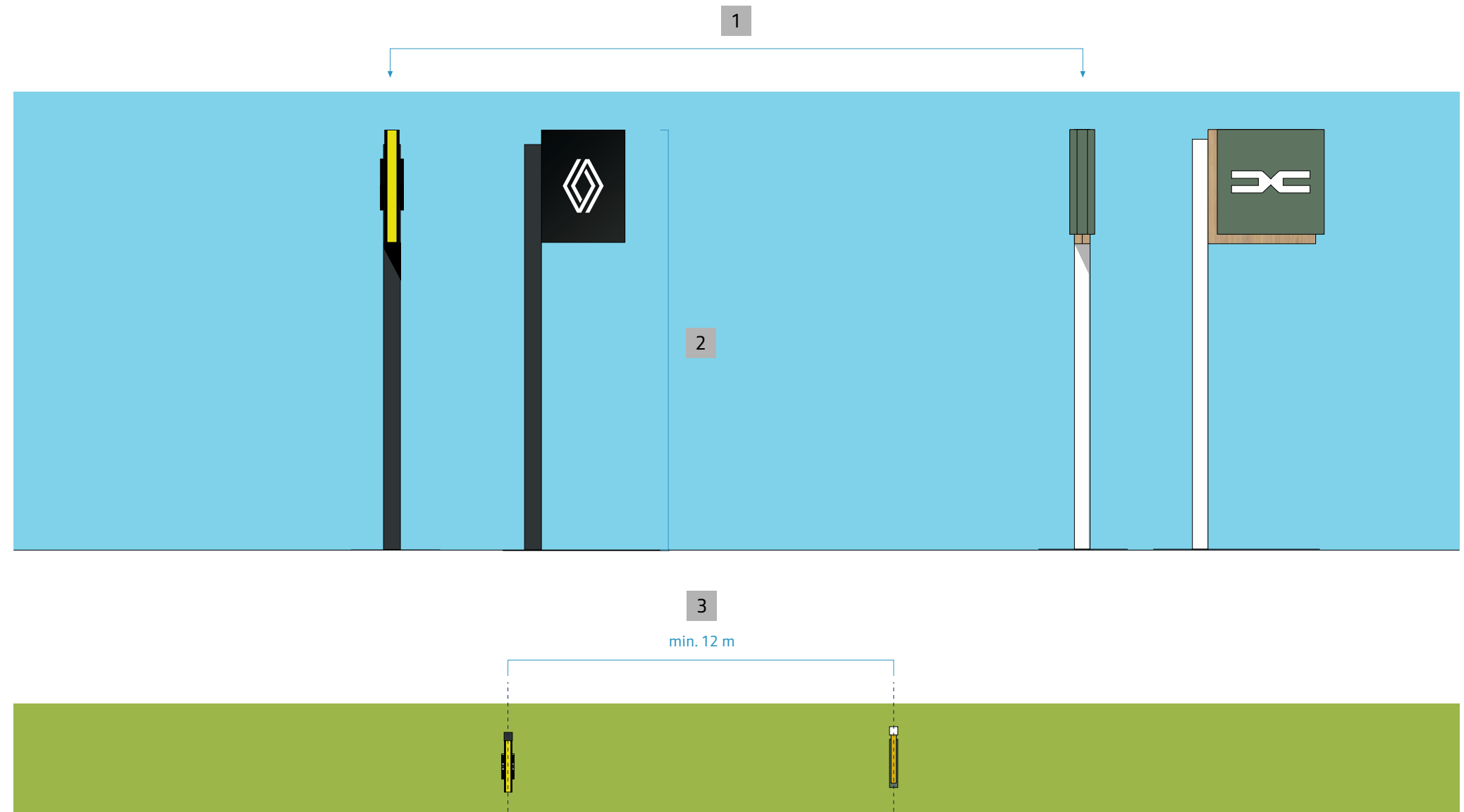

### PRINCIPLES

- 1 Signs are used in urban sites or where totems cannot be installed.
- 2 Sign masts must be the same size (4.5 or 6.5 m masts), signs must have a similar impact.
- 3 Minimum distance between 2 flag insignias on mast is 12 m.

## 2.2.8 Totems and flag insignias • Don't

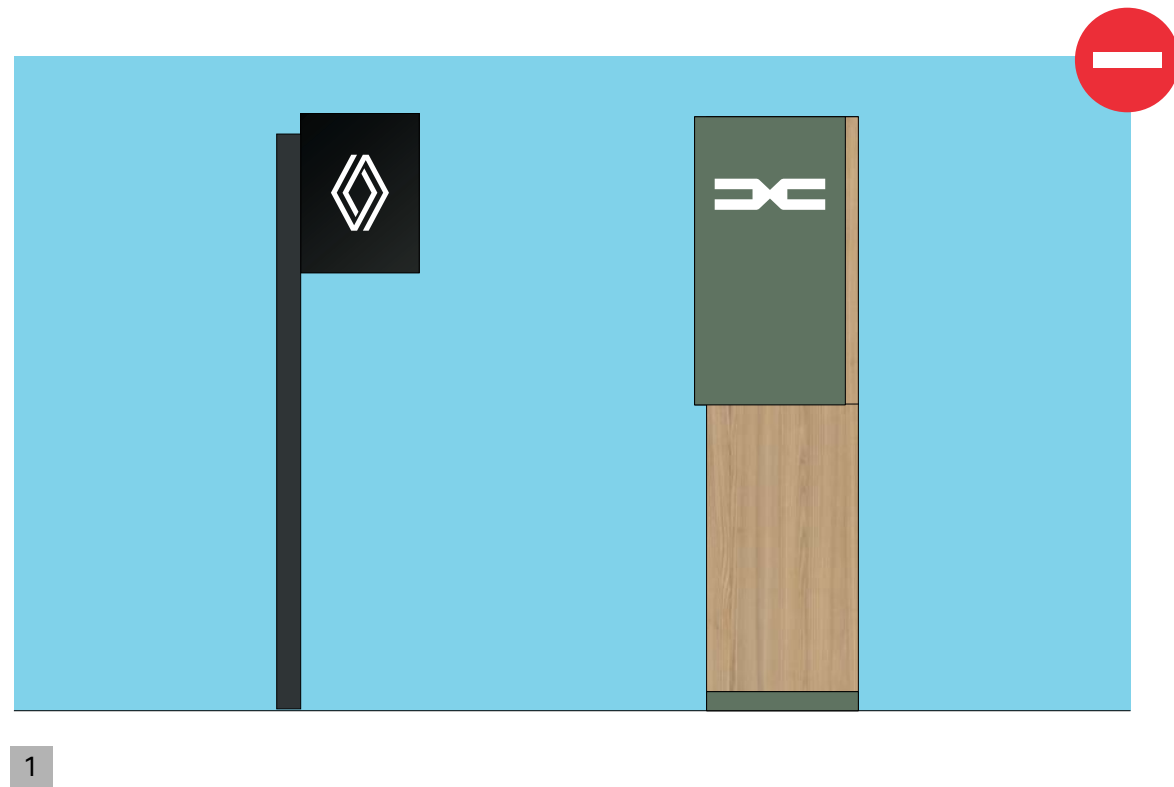

### MAIN PROHIBITIONS

- 1 Signs on masts must not be used in combination with a brand totem.
- 2 Multi-brand signs mounted on masts are reserved for the R2 commercial network.

# 2.3

## CUSTOMER PARKINGS



## 2.3.1 Fundamentals

### **Generic implementation rule**

On a Renault Dacia multi-brand site, customer parking lots are dedicated to each brand and located in front of the facades of the respective showrooms.

It is recommended to give priority to customer parking lots and, if necessary, to relocate test drive areas and product areas to the side facades.

Common directional signage guides customers, helping to connect the different areas to the brand showrooms.

### **Possible adaptation**

It is possible to create a common customer parking lot associated with a common Renault Dacia test drive area.

### **Don't**

With the exception of parking lots dedicated to the different brands, it is advisable to avoid the presence of brand identity signs in the different common areas.

## 2.3.2 Hierarchy of components

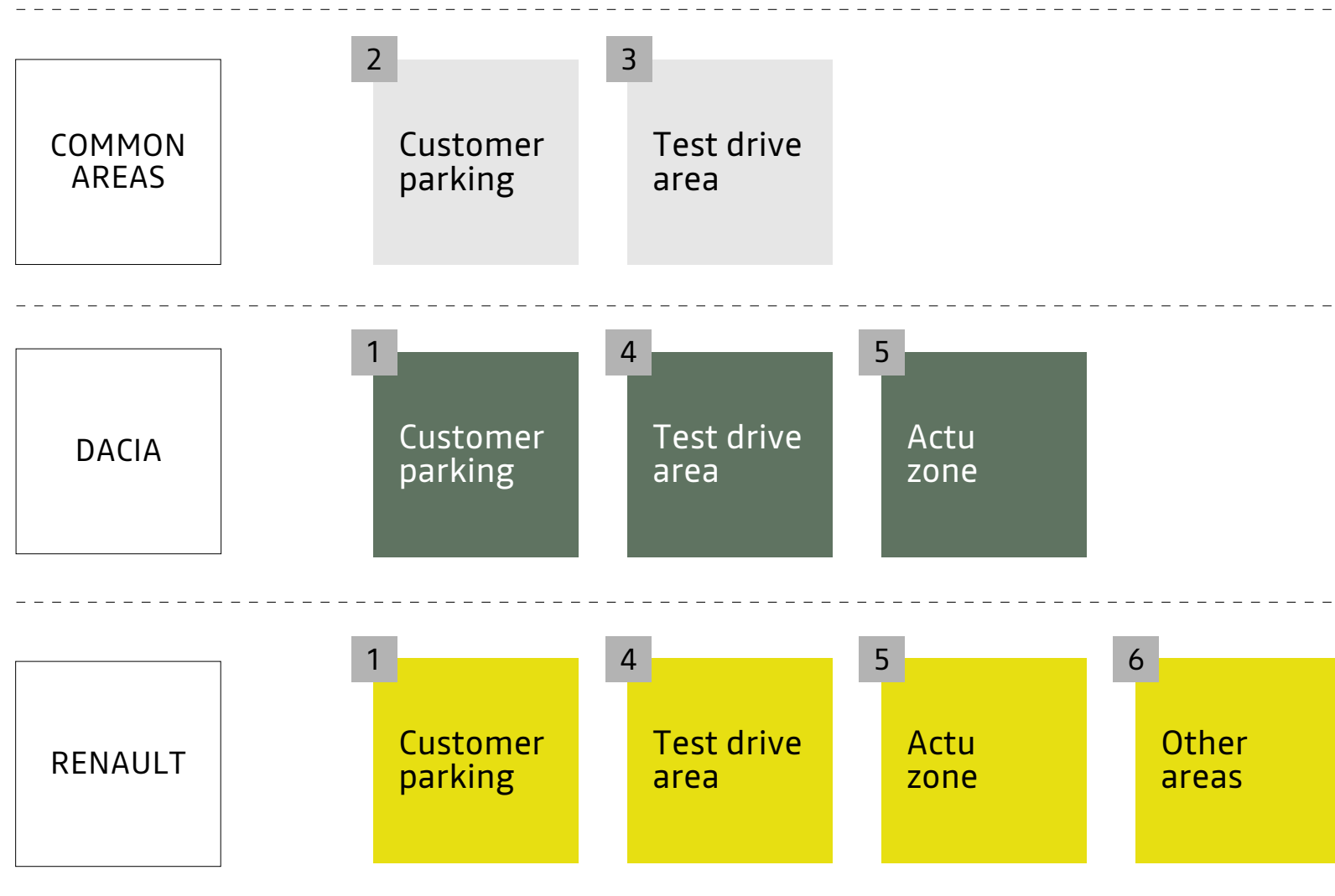

### GENERIC RULE

**Priority must be given to the installation of the customer car park(s).**

The table opposite indicates the priority between the components of the surroundings of the sites that must be respected during a new installation.

### PRINCIPLE OF ADAPTATION

In the case of the transformation of a site, the priorities can be modified according to the economic constraints of the site and must be treated on a case-by-case basis.

## 2.3.3 General layout

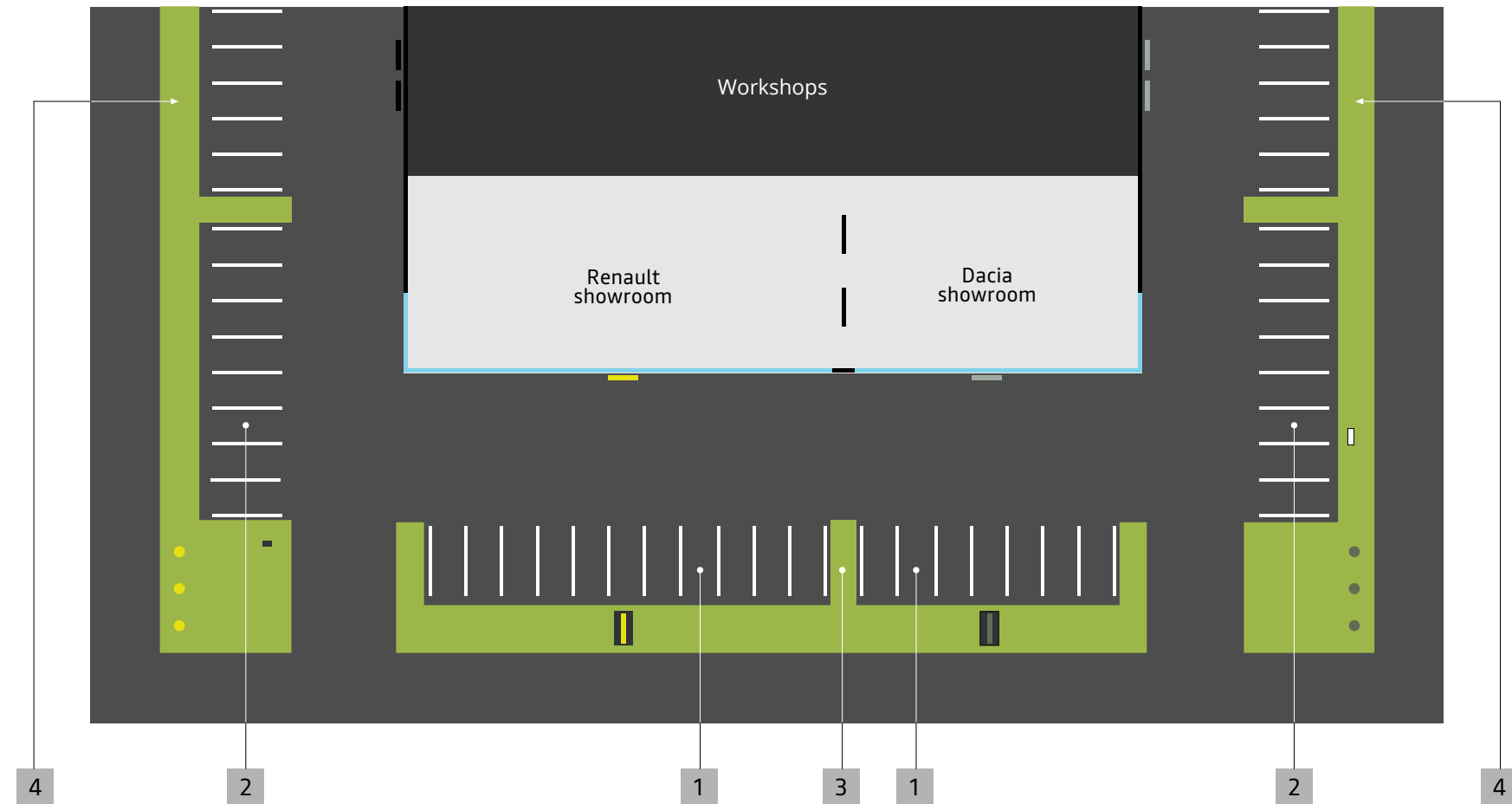

### IMPLEMENTATION PRINCIPLES

- 1 Customer parking lots are separate for each brand. As a priority, they are located in front of the showrooms
- 2 In addition, parking lots can also be arranged on the sides of the building.
- 3 Where possible, a central reservation creates a separation between the different parking lots dedicated to each brand.
- 4 On the after-sales facade, the after-sales parking lots are located near the workshop bays dedicated to each brand.

## 2.3.4 Separate customer parkings

### PRINCIPLE

As far as possible, it is recommended to install parking lots dedicated to each brand in front of the facade of the showrooms.

### DESCRIPTION OF COMPONENTS

- 1 Pedestrian passages, marked out in white paint, in accordance with the Highway Code, connect the parking spaces to the entrances of the showrooms.
- 2 The priority spaces for PRMs are in accordance with the Highway Code. At a minimum, one PRM space is provided in each parking area.
- 3 The spaces, in the standard European format 2300 x 5000 mm, do not have any distinctive signs specific to the brands. They are marked out on the ground using two-component white epoxy paint.
- 4 Optional separation of the parking lots dedicated to each brand.

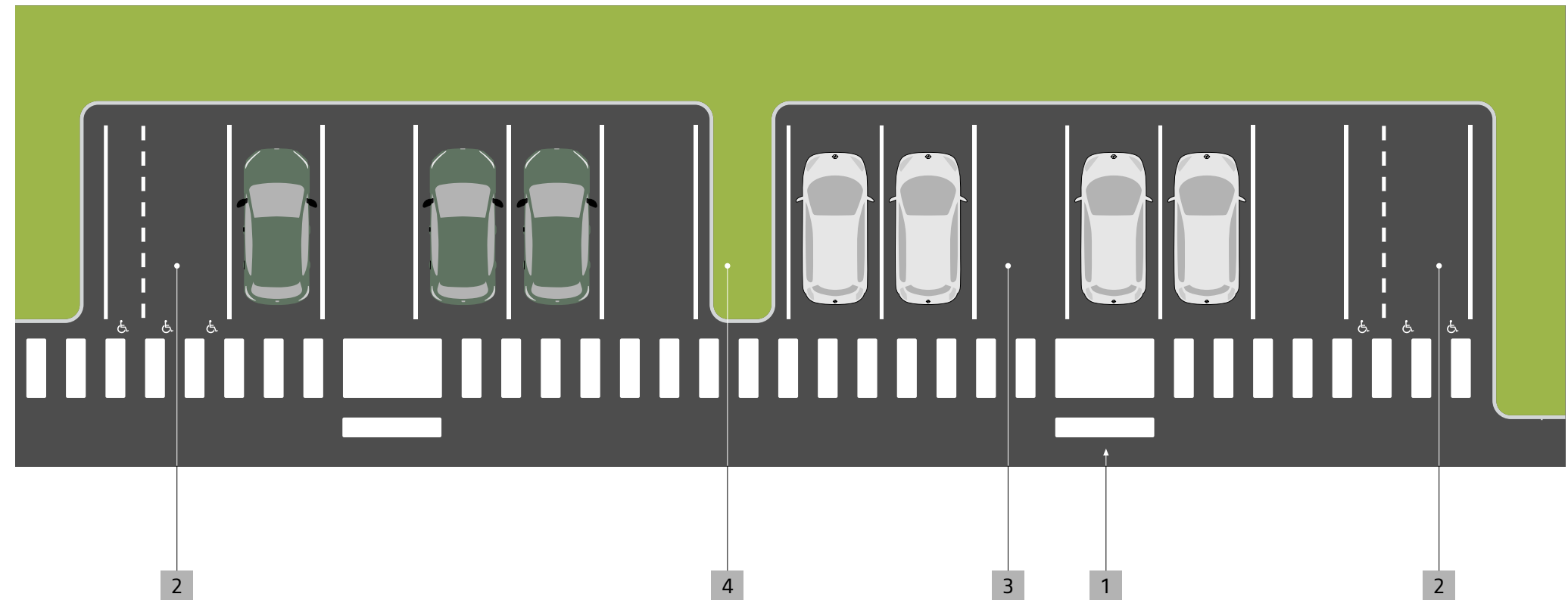

## 2.3.5 Parking lot shared by the different brands

### PRINCIPLE

Where it is not possible to set up separate car parks for each brand, it will be possible to create a common car park.

### DESCRIPTION OF COMPONENTS

- 1 Pedestrian passages, marked out in white paint, in accordance with the Highway Code, connect the parking spaces to the entrances of the showrooms.
- 2 The priority spaces for PRMs are in accordance with the Highway Code. At a minimum, one PRM space is provided in each parking area.
- 3 The spaces, in the standard European format 2300 x 5000 mm, do not have any distinctive signs specific to the brands. They are marked out on the ground using two-component white epoxy paint.

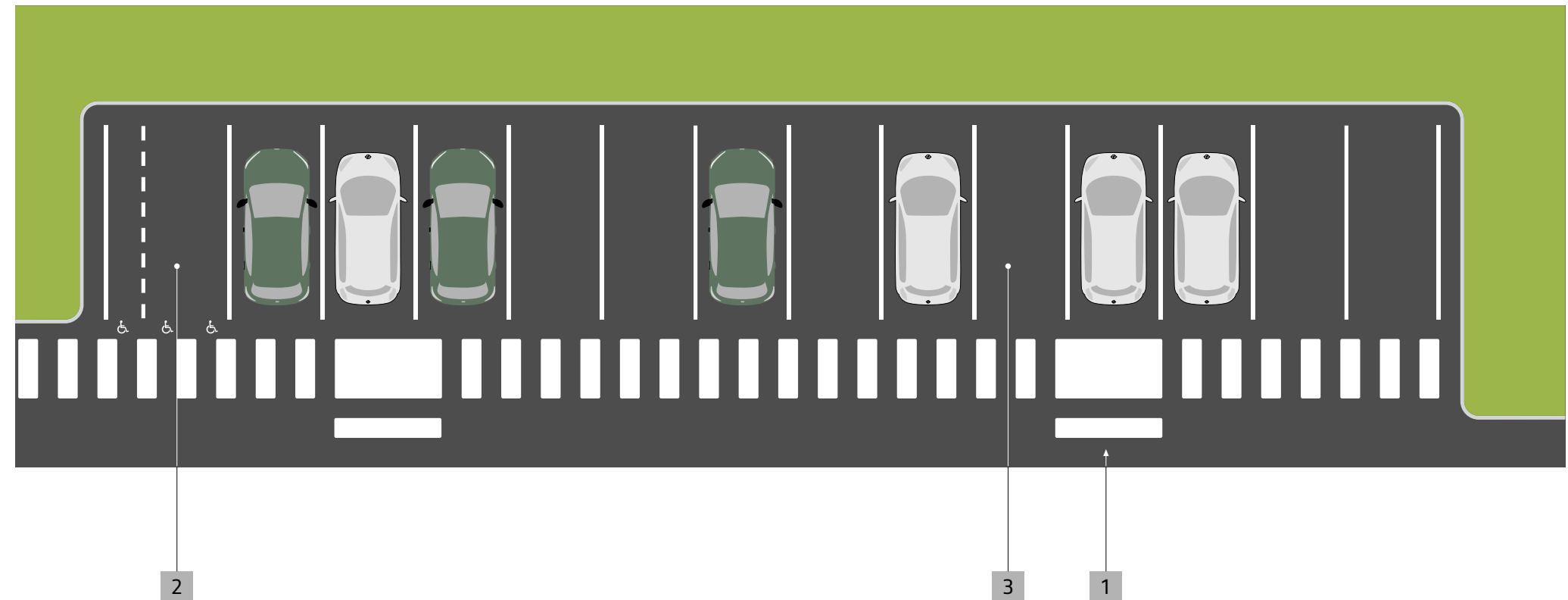

## 2.3.6 Renault Dacia test drive area

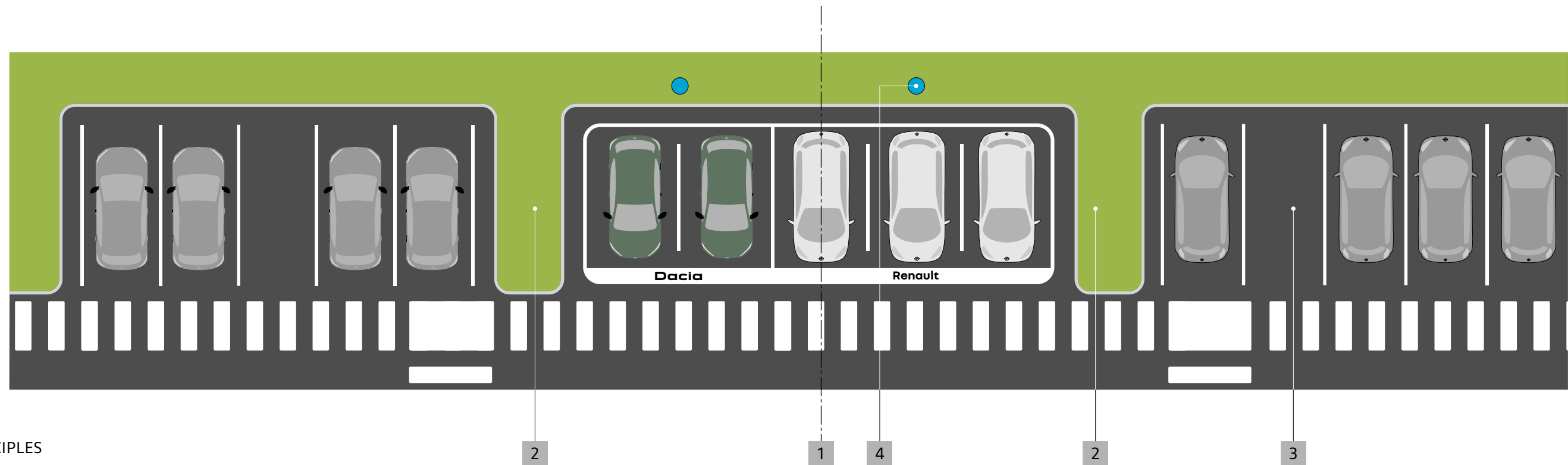

### PRINCIPLES

- 1 The common test drive area, when it exists, must be located in the axis of the separation of the showrooms of the Renault Group brands. **Only Renault or Dacia brand vehicles may be presented in this area.**
- 2 In order to highlight these vehicles, it is recommended to separate the test drive area from the Renault Group brand car parks by central reservations.
- 3 Parking areas are located on either side of the common test drive area in front of their respective showrooms.
- 4 Charging stations are present in the test drive areas, possibly shared between the vehicles present in these zones.

## 2.3.7 Separate test drive areas

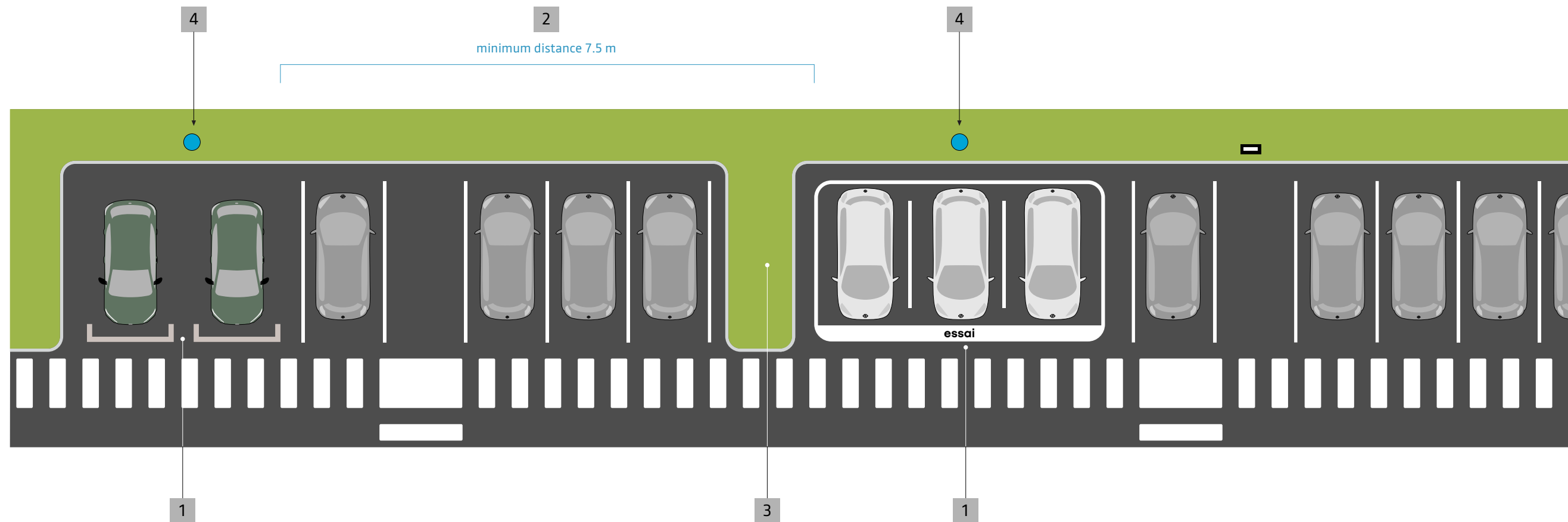

### IMPLEMENTATION PRINCIPLES

Regarding existing sites:

- 1 Specific test drive areas for each brand can be integrated into the customer parking area dedicated to these brands.
- 2 These areas will always be separated by a minimum distance equal to 3 parking spaces (7.5 m).
- 3 Preferably and optionally, the test drive areas are separated by a central reservation.
- 4 Charging stations are present in the test drive zones, possibly shared between the vehicles present in these zones.

## 2.3.8 Directional signage

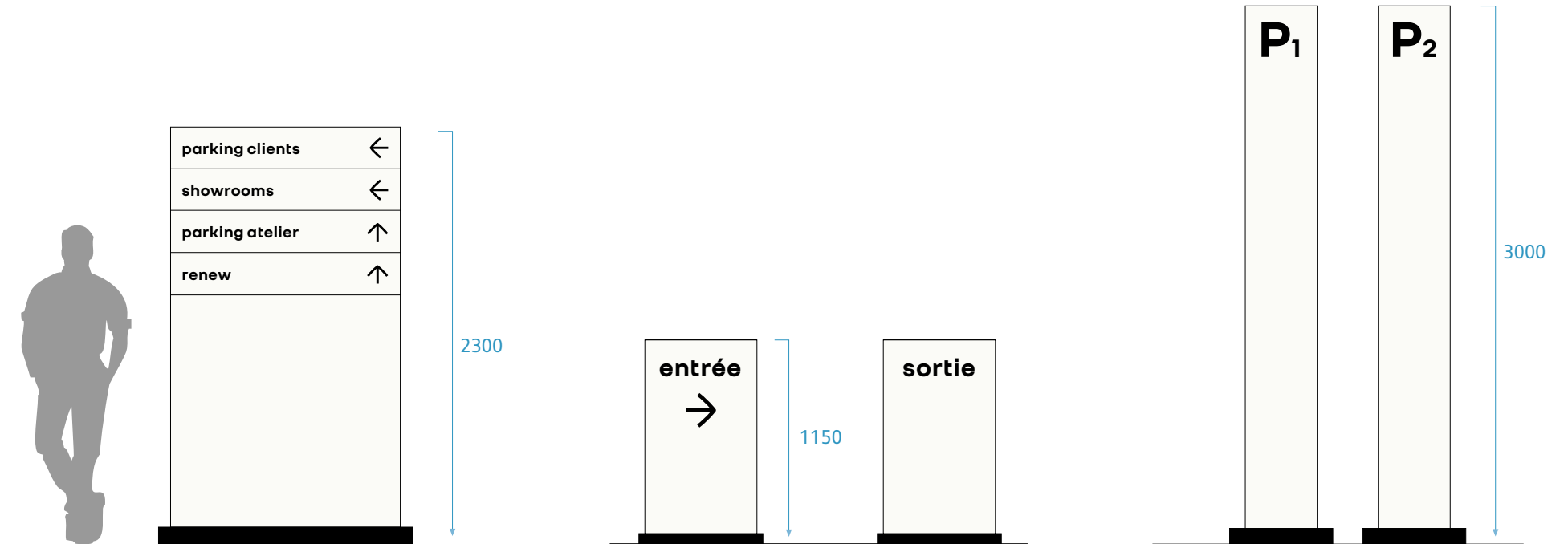

### GENERIC RULE

Multi-brand directional signage must be used.

**No mention of brands (brand name or logotype) must appear on these elements with the exception of the renew and Renault Pro+ names.**



## 2.3.9 Directional signage • Don't

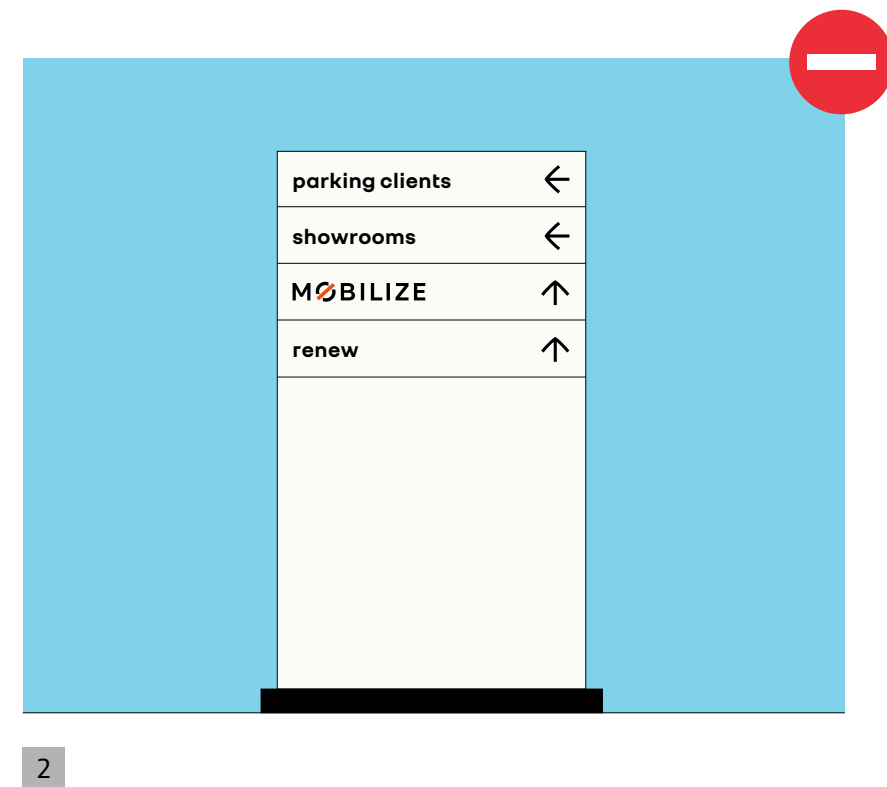
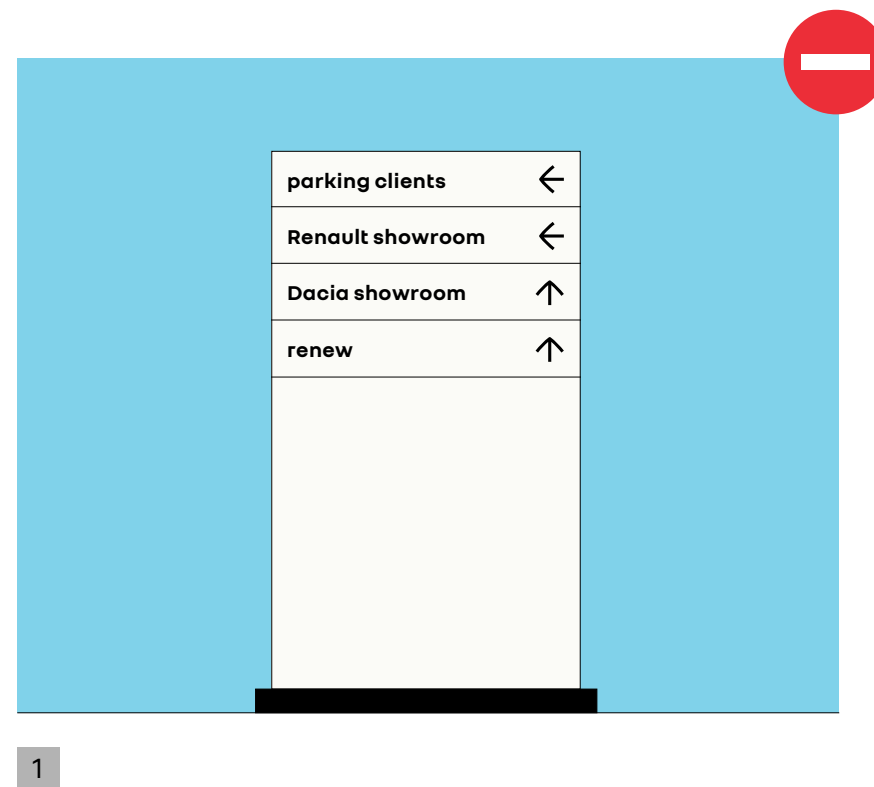

### MAIN PROHIBITIONS

- 1 Use of brand names in titles is prohibited.
- 2 Use of visual identities of brands is prohibited.

# 3

## IDENTIFICATION OF SHOWROOM FACADES

# 3.1

TYPICAL FACADES OF NEW CONSTRUCTIONS

## 3.1.1 Fundamentals

### **Generic rule**

Renault and Dacia Showroom facades are identified by the full application of the signage elements of each brand.

A white separation of 1 m width is recommended to allow harmonious cohabitation of the components of the 2 brands.

Access to each showroom is via a dedicated entrance door.

### **Possible adaptation**

On narrow facades, it is possible to reduce the neutral separation distance between the 2 facades by respecting certain conditions.

### **Don't**

In the case of new constructions or major reorganization of a site, the glazed part of facades cannot be juxtaposed.

### 3.1.2 Typical facade of Renault Dacia multi-brand sites



#### PRINCIPLES

- 1 The visual identity systems of the different brands are applied on the fronts of each of the showrooms, in a balanced manner.
- 2 A white vertical separation with a minimum width of 1 m accentuates the separation between the brands.

### 3.1.3 Reverse configuration

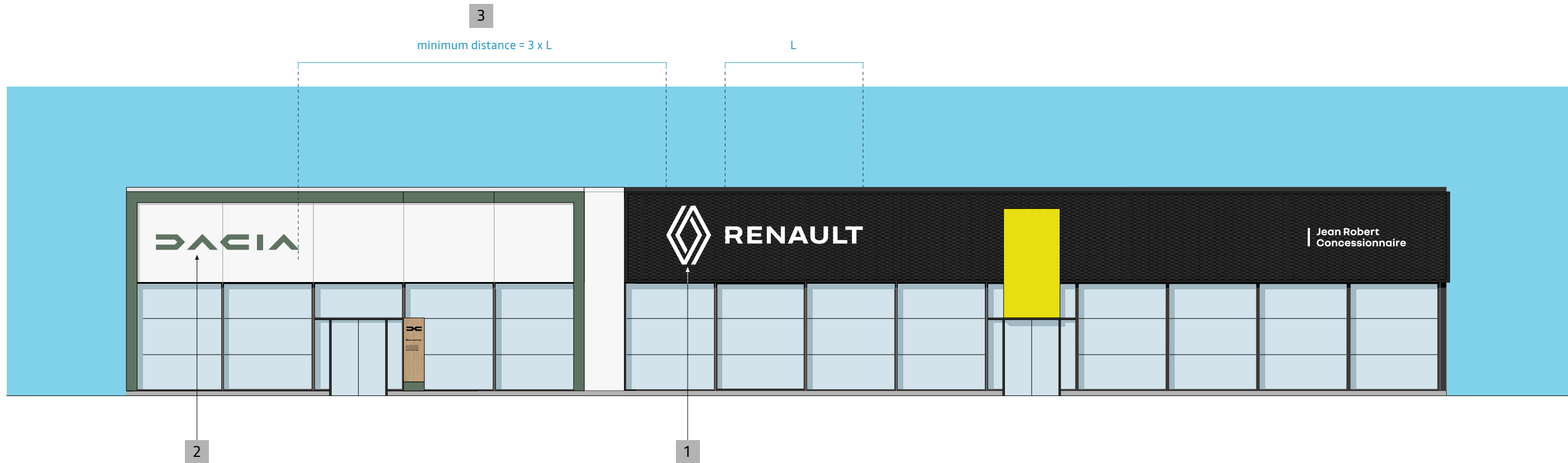

#### PRINCIPLE

- 1 Preferably, the Renault signature is placed on the left of the façade, following the reading direction.
- 2 The Dacia signature is placed on the left of the façade.
- 3 A minimum distance equal to 3 x the length of the Renault logotype must be respected between the signatures.
- 4 In the case of a narrow façade, the Renault signature should be placed opposite the Dacia signature.

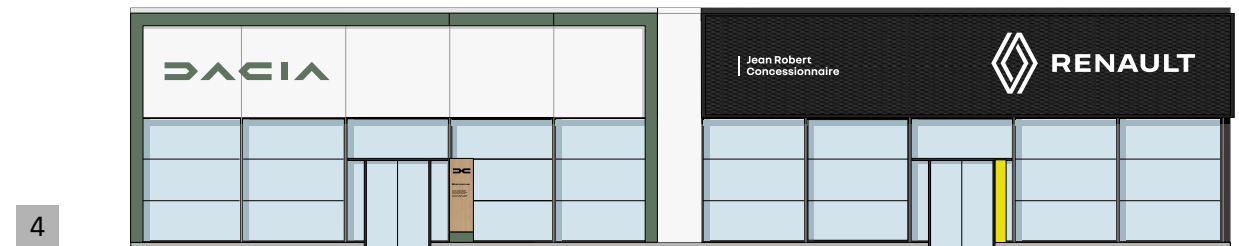

### 3.1.4 Optional reinforcement of the facade unit of a Renault Dacia site



**PRINCIPLE**

- 1 A vertical upright reinforces the unity of the façade while accentuating the separation between the façades.

This dark grey element takes up the dimensions of the outline present on the Dacia façade.

### 3.1.5 Separation optimization for narrow facades

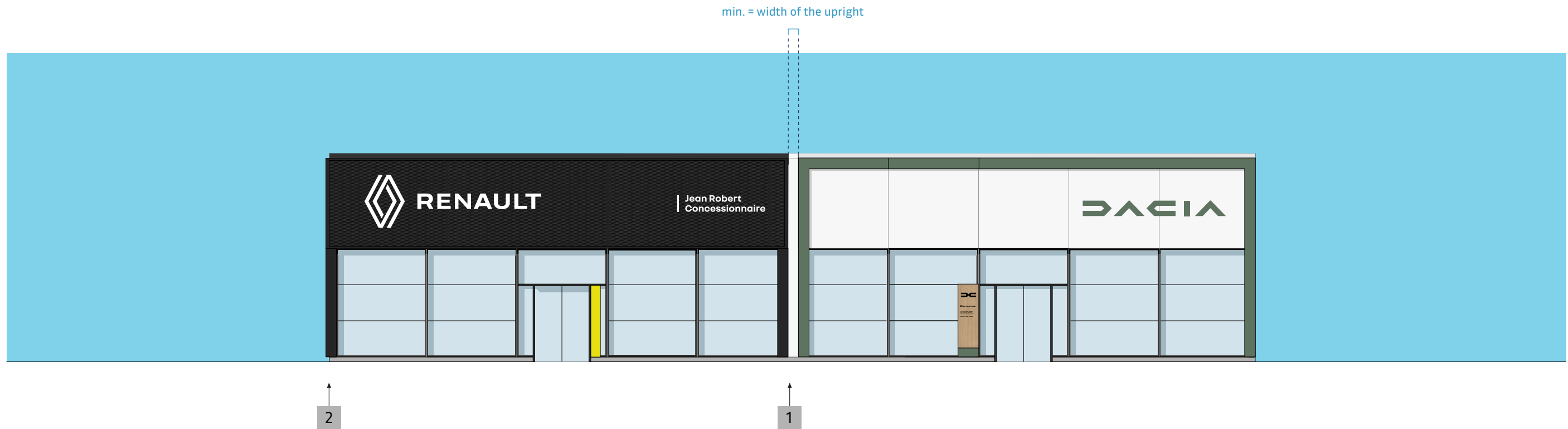

#### PRINCIPLE

- 1 In the case of a narrow façade, it is possible to reduce the separation distance between the 2 façades of the showrooms.  
At a minimum, this distance will be equal to the width of the vertical uprights present on either side.
- 2 In the case of a separation distance of less than 1m, the use of vertical uprights is required.



### 3.1.6 Proportions of the typical facade of Renault Dacia sites



**PRINCIPLE**

The proportions between the facade lengths dedicated to the Renault and Dacia brands must be between 66/34% and 50/50%.

## 3.1.7 Secondary facades

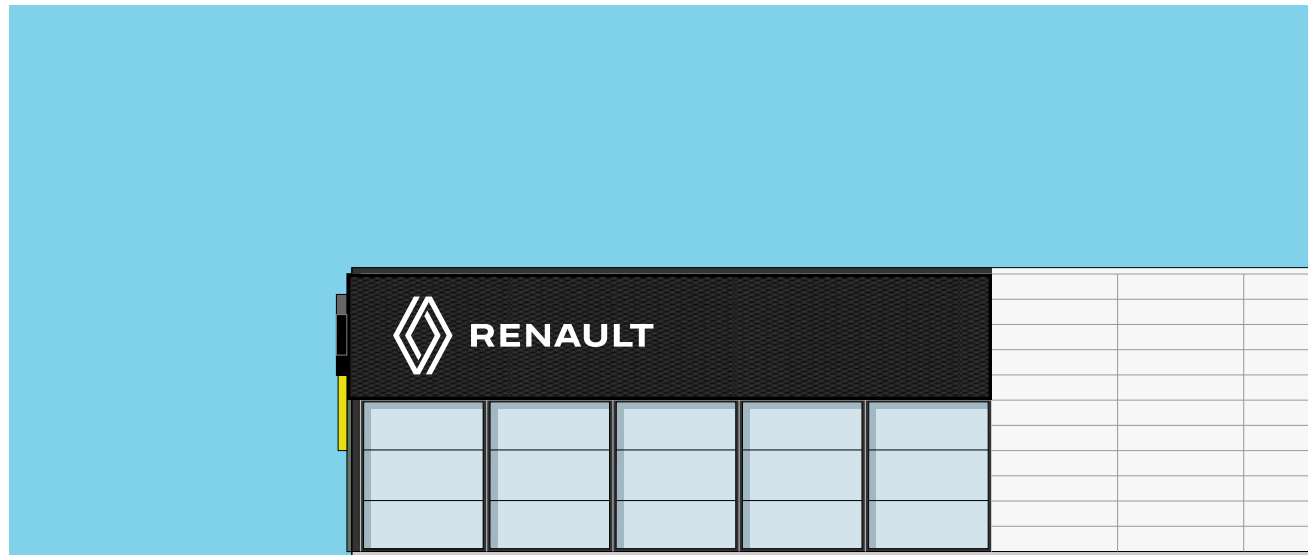

Example of a Renault right side facade

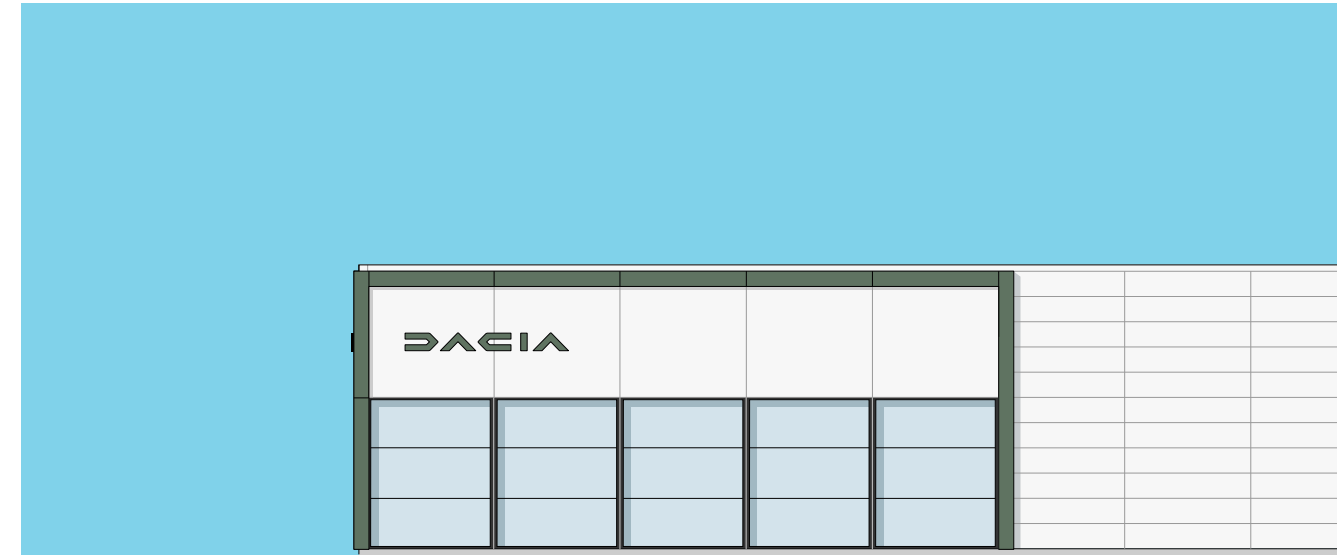

Example of a Dacia right side facade

### PRINCIPLES

- 1 The secondary facades of the different showrooms are identified with their respective system.
- 2 Dimensions of the signatures on the secondary facades are identical to those on the main facade.
- 3 Dealername is never present on a secondary facade.

### 3.1.8 Blind facades

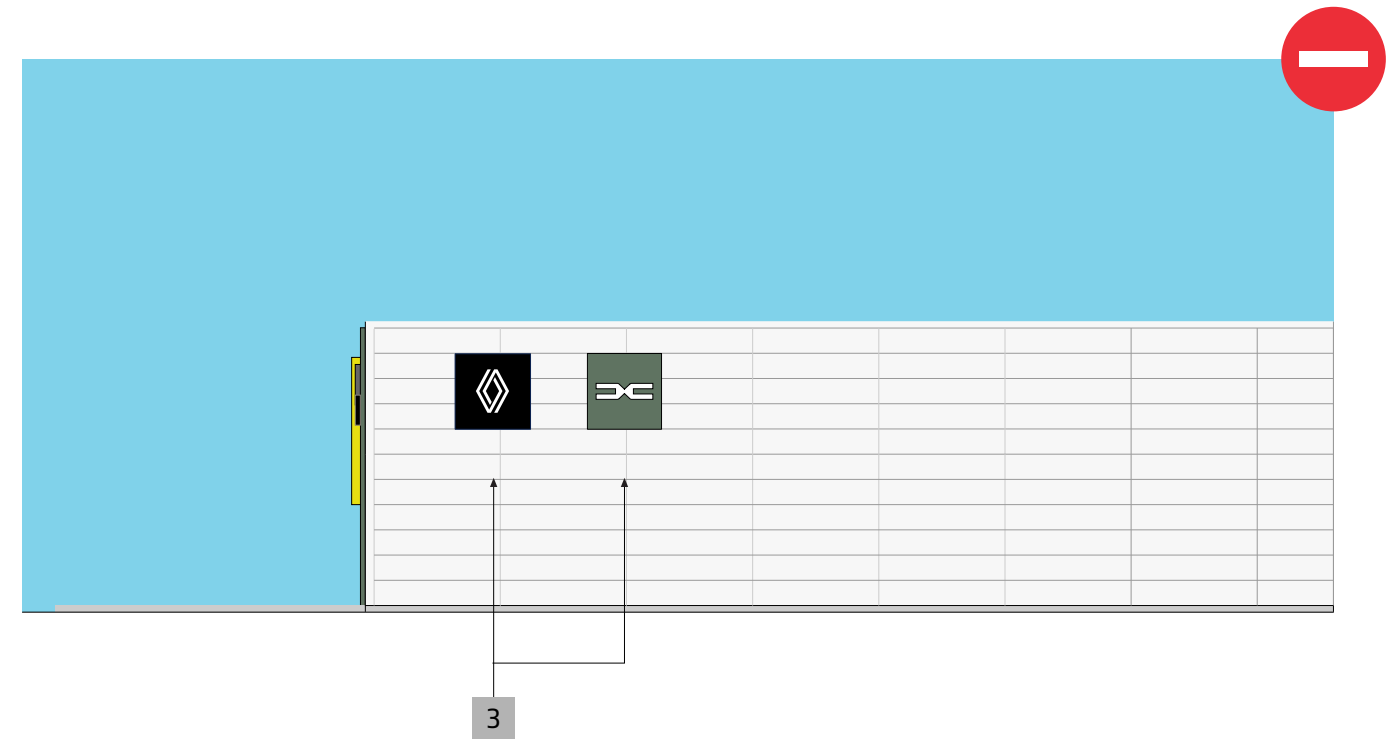
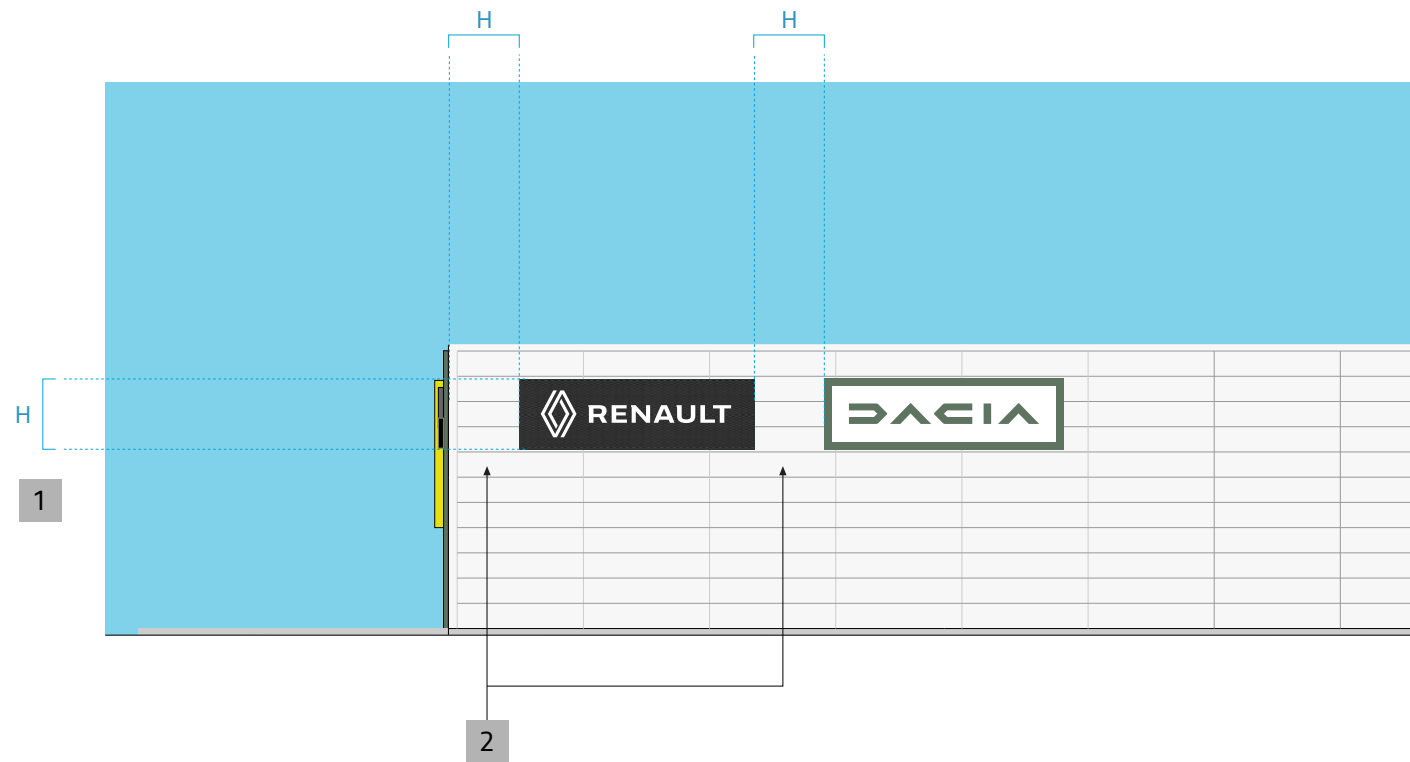

#### PRINCIPLES

- 1 Signatures provide a similar impact creating a harmonious façade thanks to a common height.
- 2 Implantation distance between each signature is identical.
- 3 **Emblems alone must not be used on secondary façades in place of brand signatures.**

### 3.1.9 Not allowed

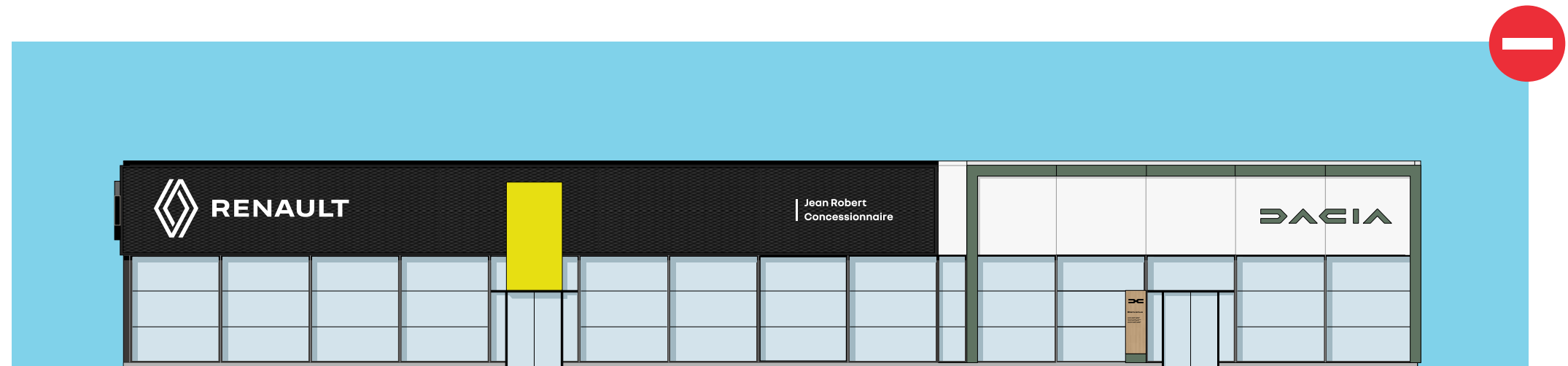
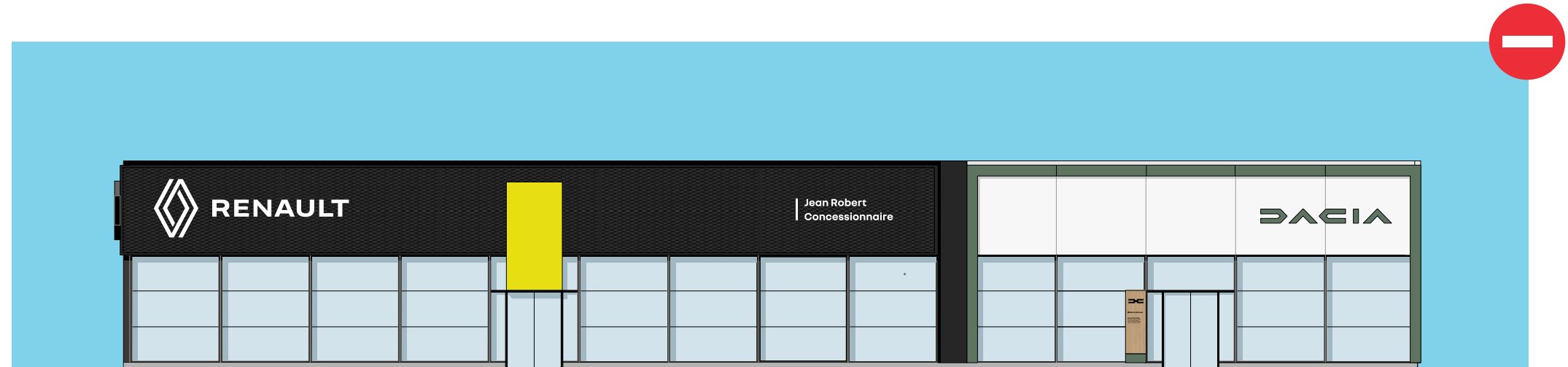

#### MAIN PROHIBITIONS

- 1 Change in color of the separation between the windows.
- 2 Absence of separation or non-compliant separation width.

3.2

SHOWROOMS ENTRANCES

## 3.2.1 Fundamentals

### **Generic implementation rule**

Each showroom has a dedicated entrance fully identified by the identity system of the brand present.

A minimum distance of 12 m (plus the neutral separation between facades) must be observed between each entrance door in order to avoid any confrontation of the identity signs of the brands.

### **Don't**

Neutral common entrances are to be prohibited.

### 3.2.2 Dedicated entrances to each showroom



#### PRINCIPLES

- 1 An entrance is dedicated to access each of the showrooms in order to offer customer journeys specific to each of the brands.
- 2 These entrances are identified by the signage of each of the brands, generally combining identification panel, opening hours and markings of the glass parts.

### 3.2.3 Minimum distance between entrances

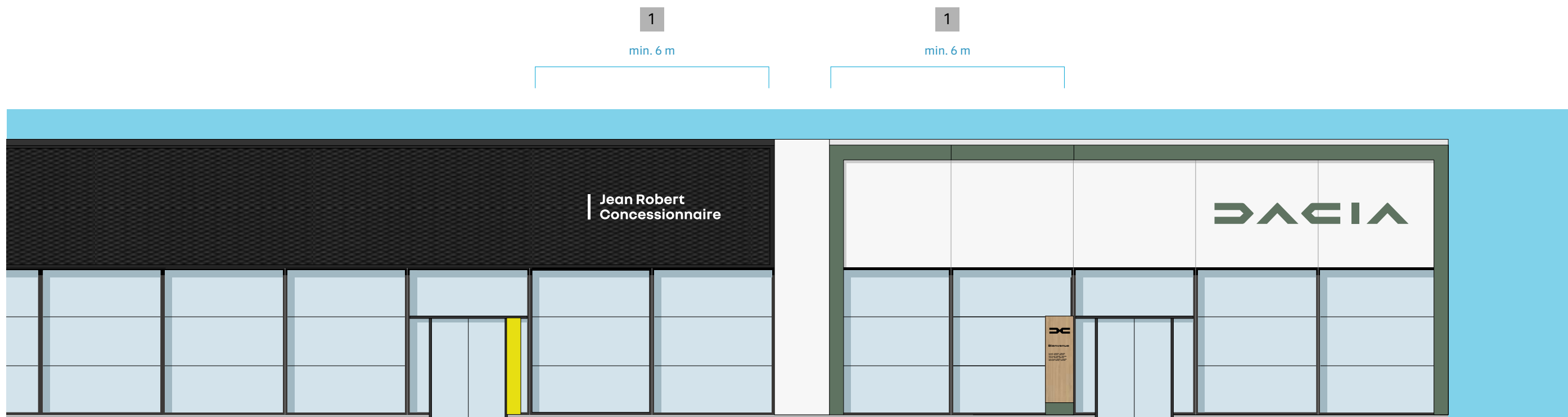

#### PRINCIPLE

- 1 A minimum distance of 6 m should be respected between the edge of the entrance door and the end of the window dedicated to the brand.

This arrangement allows a model of the brand to be presented in the window near the entrance door without interfering with the vision of customers of other brands.



### 3.2.4 Not allowed

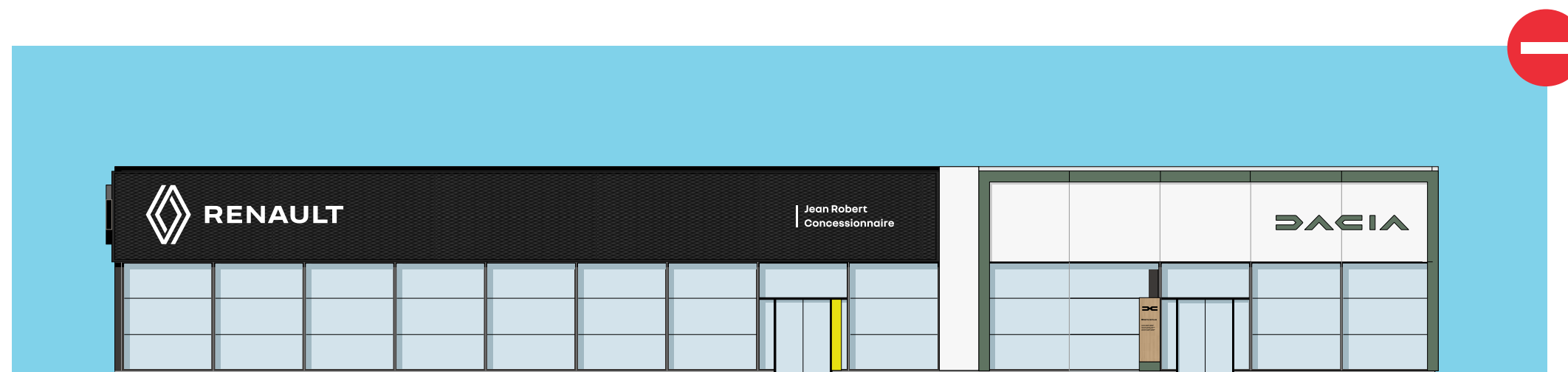

#### MAIN PROHIBITIONS

- 1 Common entrance to the showrooms.
- 2 Entrance to the Renault showroom positioned less than 6 m from the Dacia showroom.

4

SHOWROOMS

# 4.1

## GENERAL IMPLEMENTATION

## 4.1.1 Fundamentals

### **Generic implementation rule**

Brand universes are fully expressed in the respective showrooms of the different brands (refer to the guides of each brand).

In the rear part, the showrooms are open to the common services with neutral tiling. A 2 m wide circulation aisle connects the various interior and exterior common services.

### **Adaptation possible**

It is possible to adapt the width of the circulation aisle according to the surfaces available in each of the sites.

### **Special case**

For any new construction or construction not meeting the current Dacia standards, the use of the same tiling ("Renault") for the Renault and Dacia exhibition areas is recommended.

## 4.1.2 Tiling of Renault Dacia multi-brand showrooms

### Case 1. New constructions or major renovation

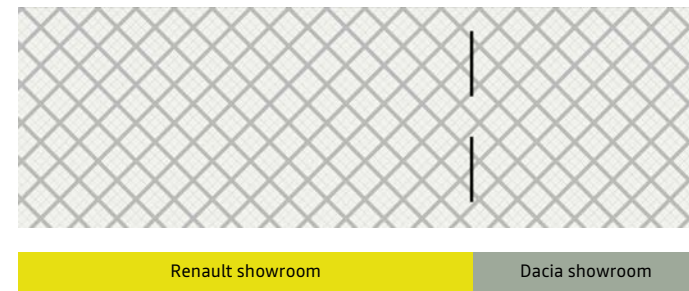

### Case 2. Retrofit of New'R Store sites

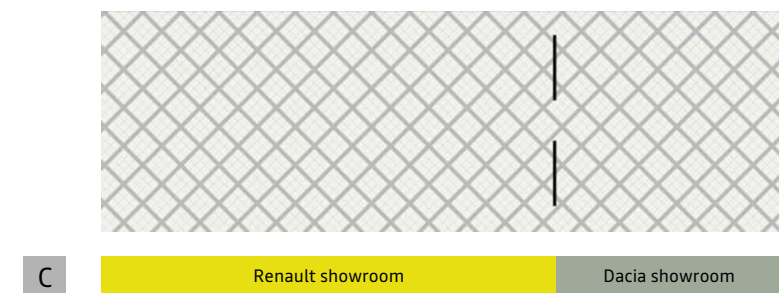
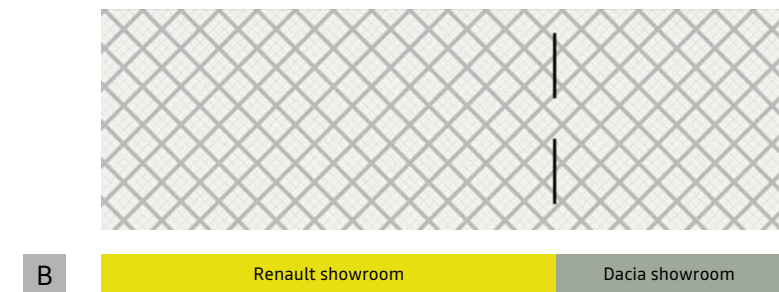
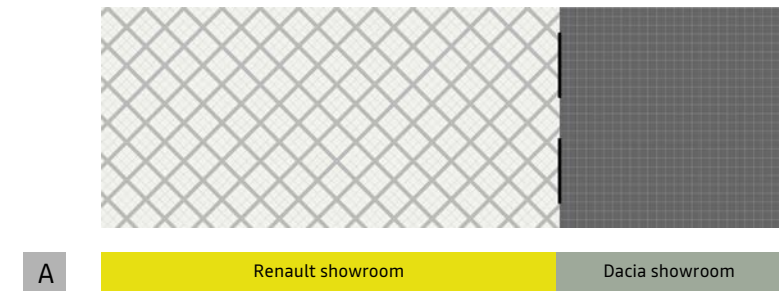

#### IMPLEMENTATION PRINCIPLES

##### Case 1. New constructions or major renovation

Les surfaces d'exposition utilisent le même carrelage blanc et gris clair disposé à 45°.

##### Case 2. Retrofit of New'R Store sites

- A. If the Dacia showroom complies with current standards, dark grey tiles are used for the Dacia showroom.
- B. If the Dacia showroom does not comply with current standards, white and light grey tiles arranged at 45° are used for the Renault & Dacia showrooms.
- C. For the Mini format, white and light grey tiles arranged at 45° are used for the Renault & Dacia showrooms.

## 4.1.3 Generic principles

### IMPLEMENTATION PRINCIPLES

**Brand universes are fully expressed in the respective showrooms of the different brands.**

The identity components (including tiling) contribute to brand recognition and the delimitation of the affected areas.

- 1 White and light grey tiling arranged at 45° identifies and delimits the surface dedicated to the presentation of Renault vehicles.
- 2 As an option, dark grey tiling identifies and delimits the surface dedicated to the presentation of Dacia vehicles.
- 3 Transparent self-supporting partitions separate the Dacia and Renault showrooms. They are specific to these 2 brands and cannot be used with other brands.
- 4 Brand walls located opposite each other identify the respective showrooms.
- 5 A circulation aisle with specific tiling separates the common areas of the showrooms.
- 6 Renault sales offices are located on the edge of the Renault showroom in order to optimize the presentation of vehicles in the showroom.
- 7 The common areas (waiting lounge and service reception) are open to the showrooms so as to be visible from the entrances of each of the brands.



### 4.1.4 Standard showroom surfaces

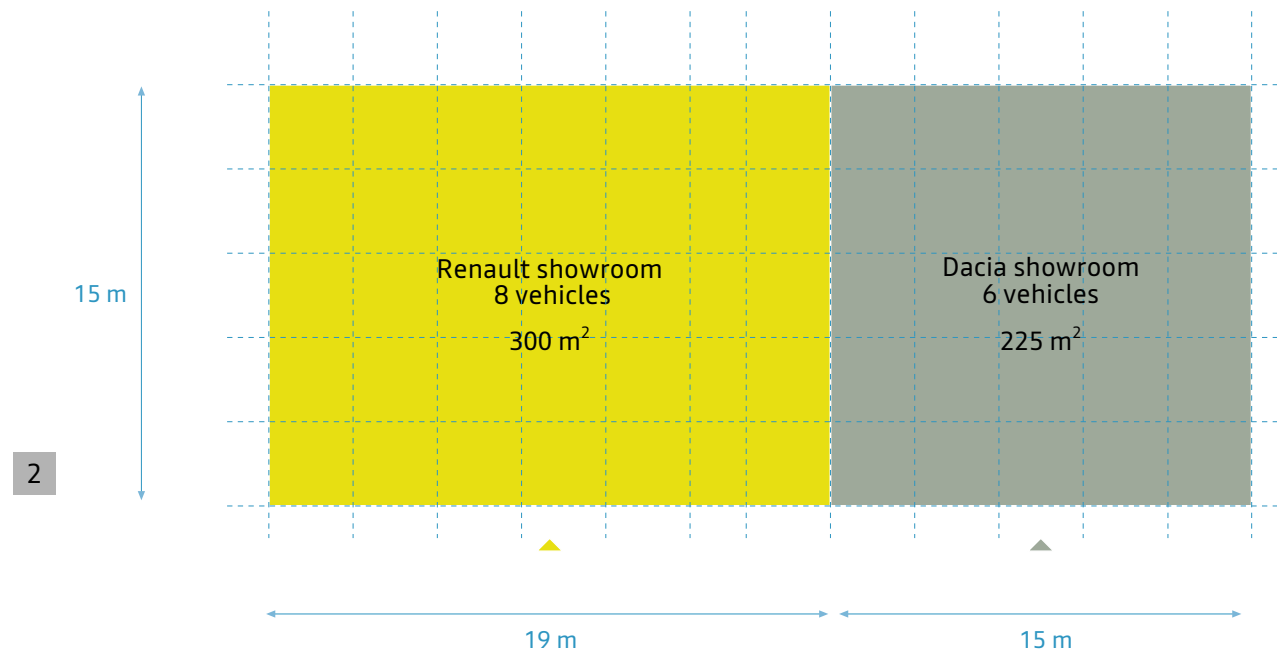
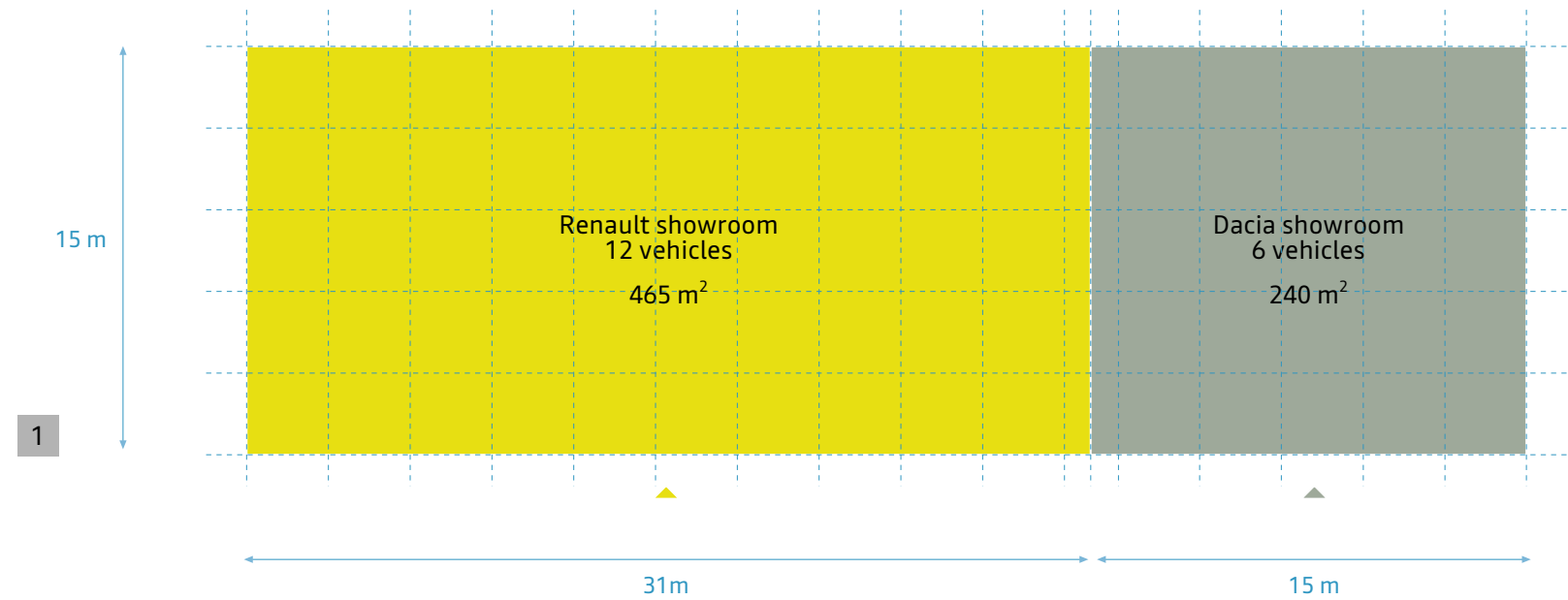

**PRINCIPLES**

The challenge for the Renault and Dacia brands is to display all the models in their ranges.

The examples opposite illustrate the standard areas allocated to the showrooms of the 2 brands.

- 1 Configuration combining 12 Renault vehicles with 6 Dacia vehicles.
- 2 Configuration combining 8 Renault vehicles with 6 Dacia vehicles.

## 4.1.5 Proportions between showrooms

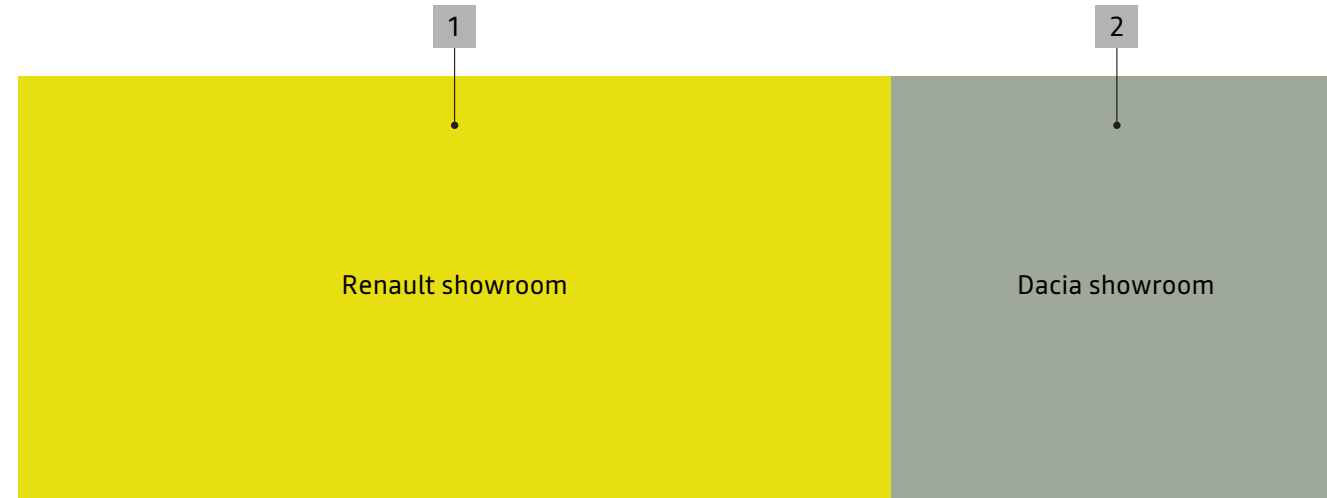

### PRINCIPLES

The examples opposite illustrate the common proportions between the surfaces allocated to the showrooms of the 2 brands.

Please note that the respective position of the showrooms can be reversed.

- 1 Standard configuration based on a proportion of around 70% - 30%.
- 2 In some countries, the proportion between the surfaces of the 2 showrooms can be 50% - 50% (reversed configuration in the example).



## 4.1.6 General organization of a multi-brand site

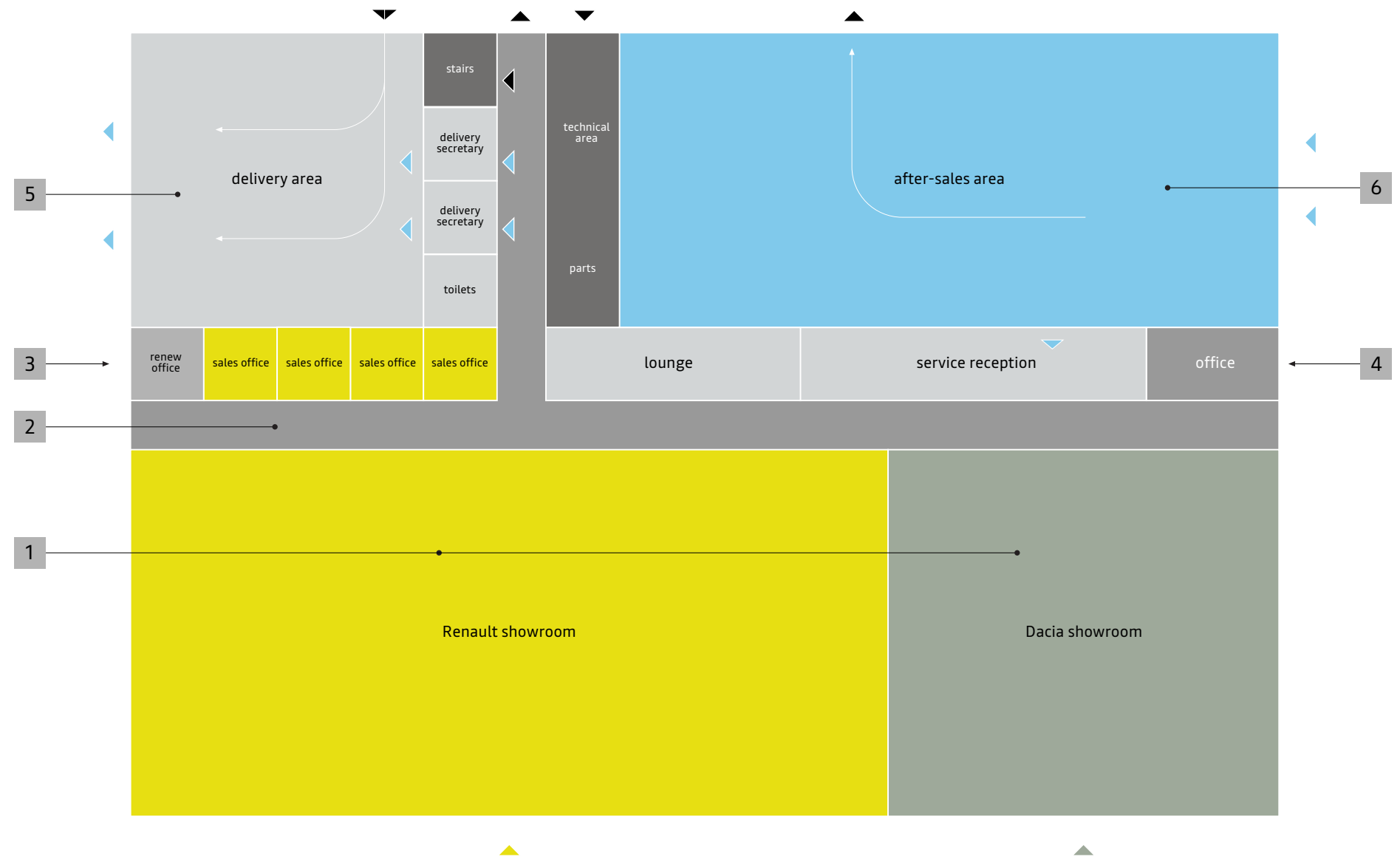

### PRINCIPLES

- 1 Showrooms are always located in the foreground.
- 2 Circulation aisles provide a link between the different spaces. They help to highlight the brands' universes by creating a clear separation of the common areas.
- 3 Sales offices are located in line with the areas dedicated to common services (waiting lounge, service reception, etc.).
- 4 Common services are organized around the service reception itself linked to the after-sales area.
- 5 Delivery area shared between the Renault and Dacia brands is located separately from the showrooms.
- 6 After-sales area allows customers to be welcomed aboard their vehicles. It is connected to the service reception.

## 4.1.7 General layout of a Renault showroom

### PRINCIPLES

Layout rules are common to Renault single-brand sites.

Refer to the Renault interior architectural charter to learn more about the rules.

- 1 The vehicles are laid out in an orthogonal layout.
- 2 Customers are welcomed in a meeting point area with a high table and stools positioned on a dark grey carpet.
- 3 Communication materials inform customers about the USPs of the vehicles presented in the showroom.
- 4 The floor is entirely covered with white and light grey tiles laid at a 45° angle to the façade.
- 5 Glass partitions mounted on plates demarcate the Renault and Dacia showrooms.



## 4.1.8 General layout of a Dacia showroom

### PRINCIPLES

The implementation rules are common with Dacia single-brand sites.

Refer to the Dacia implementation guide for more detailed rules.

- 1 Floor is fully tiled (either identical to that of Renault showrooms or dark grey).
- 2 Glazed partitions mounted on plates demarcate the Renault and Dacia showrooms.
- 3 Vehicles are arranged according to a 45° grid in relation to the facade.
- 4 A sales office is located in the heart of the showroom, visible from the entrance and from the Welcome area.
- 5 A green brand wall with the Dacia logo identifies the showroom.
- 6 A Welcome area directly accessible from the entrance is present in the center of the Dacia showroom.
- 7 Large-format panels present the USPs of the vehicles.



- 1
- 2
- 3
- 4
- 5
- 6
- 7

# 4.2

## SEPARATION OF SHOWROOMS

## 4.2.1 Fundamentals

### **Generic implementation rule**

Renault and Dacia showrooms are separated by transparent self-supporting partitions covering at least 1/3 of the depth of the showroom.

These partitions can also be used to separate the Renault and Renew showrooms.

### **Possible adaptation**

Depending on the height under the ceiling, these partitions can be taken up on the floor and the ceiling.

### **Don't**

These partitions cannot be used to separate a showroom from another brand.

## 4.2.2 Separation principle of showrooms



### PRINCIPLES

The challenge is to allow a complete expression of the brands' universes around the products without offering a confrontation.

- 1 Self-supporting transparent partitions separate the Dacia and Renault showrooms. They are specific to these 2 brands and cannot be used with other brands.

### 4.2.3 Partition walls in showrooms

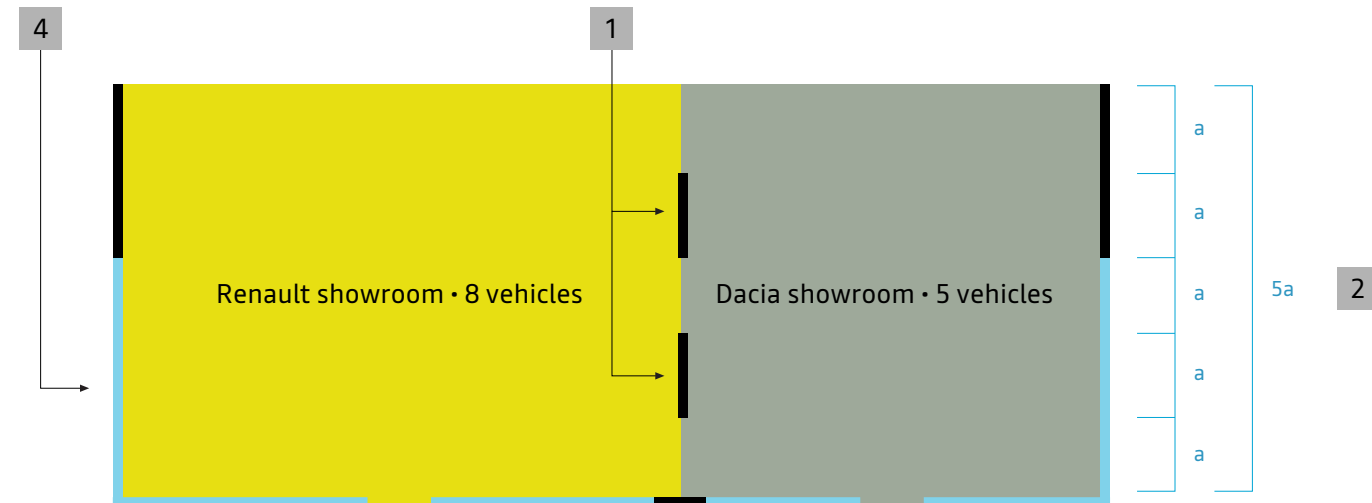
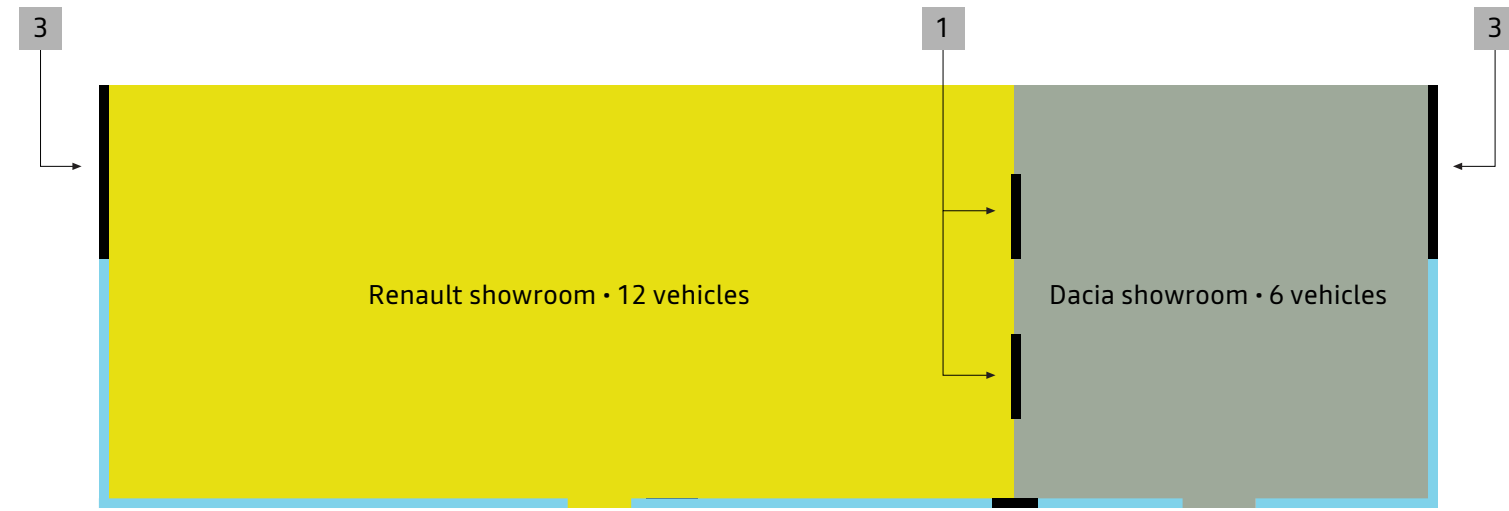

#### PRINCIPLES

- 1 Self-supporting transparent partitions separate the Dacia and Renault showrooms. They have a minimum height of 2.3 m.
- 2 These modular partitions ideally cover 2/5 of the depth of the showroom and at least 1/3 of its depth.
- 3 Some of the side facades are solid to allow the installation of brand walls.
- 4 Some of the side facades are glazed, almost the entire main facade is also glazed.

# 4.3

RENAULT & DACIA BRAND WALLS



## 4.3.1 Fundamentals

### **Generic implementation rule**

Brands' signatures are present and highlighted on one of the peripheral walls of the showrooms.

They are installed symmetrically and are visible from the showroom entrances.

Standardized formats allow for a balanced impact between these 2 signatures.

### **Possible adaptation**

The standard format of 3 x 6 m can be adapted according to the ceiling heights and depths of the showrooms.

### **Don't**

The implantation of these signatures must never be done on the same visual plane in order to avoid any confrontation of identity signs.

## 4.3.2 Renault & Dacia brand walls



### PRINCIPLES

**Renault and Dacia brand signatures are present on the adjacent walls of the showrooms.**

**They are always arranged in an opposite manner, not offering a direct confrontation of identity signs.**

1 Black Renault brand wall with white identity frame.

2 Green Dacia brand wall with white Dacia logotype.



### 4.3.3 Dimensions of Renault & Dacia brand walls

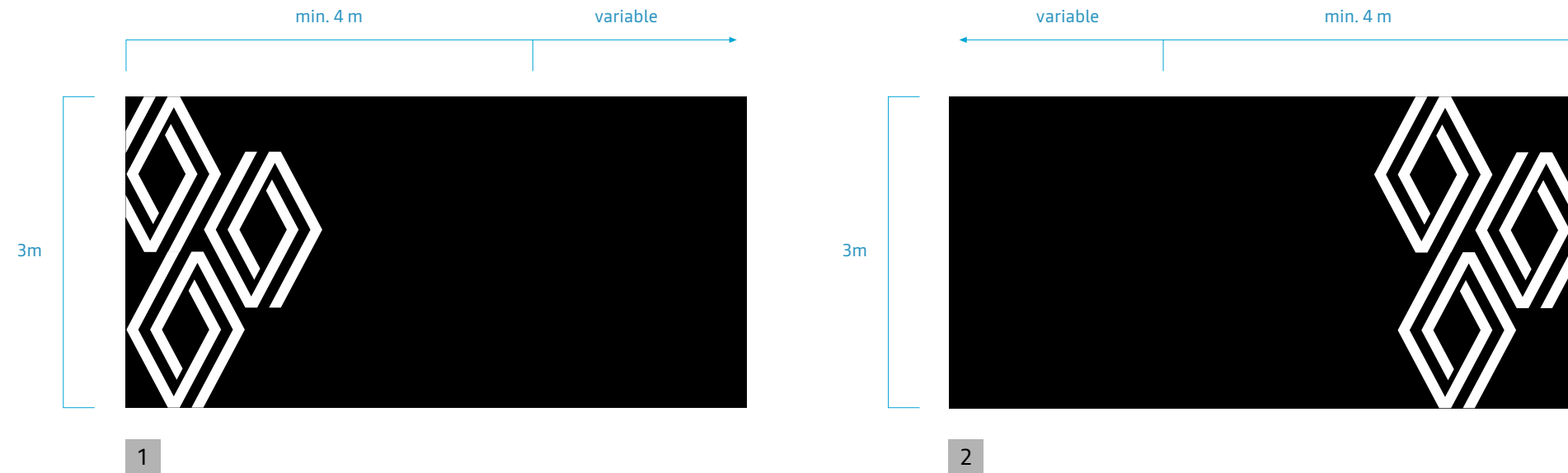

#### PRINCIPLES

In order to provide a similar and proportionate impact in relation to the different components of the showrooms, it is recommended to have brand walls of an identical height of 3 m and a minimum length of 4 m.

**Adaptations are possible for the walls of showrooms of smaller dimensions and ceiling heights of less than 3 m.**

- 1 Renault brand wall when the signature is installed on the left side wall.
- 2 Renault brand wall when the signature is installed on the right side wall.
- 3 Dacia brand wall with signature centered in the length of the wall.



4.4

DUO & BENTO DISPLAY AREA

## 4.4.1 Fundamentals

### **Generic implementation rule**

Duo & Bento display area is integrated into the Renault showroom in the rear part of it.

With a standardized format, it is equipped with merchandising furniture to communicate on this range and to highlight the products exhibited.

### **Possible adaptation**

Different standardized configurations allow to adapt the presentation to the surfaces available in the showrooms.

### **Don't**

Duo & Bento display area must never be partially or completely installed in the Dacia showroom.

## 4.4.2 Integration of the Duo & Bento display area into the Renault showroom



### PRINCIPLES

The Duo & Bento display area is integrated into the Renault showroom in the rear part close to the other 100% electric models.

- 1 This area has a carpet and POS supports to present a vehicle arranged diagonally in the area. The front of the vehicle is oriented towards the entrance door.
- 2 A neutral zone must be created around the area to allow customers to circulate around this space.

2

1

2

## 4.5.2 Layout principle

### PRINCIPLES

The Duo & Bento display area will be located in the rear part of the Renault showroom and near the Dacia showroom.

**It is forbidden to locate the Duo & Bento area in the center or in the front part of the Renault showroom.**

In order to highlight this area and allow harmonious cohabitation with the other components of the showrooms, a neutral space must be observed:

- 1 A minimum distance of 1.4 m width must be provided between the edges of the Duo & Bento area and the vehicles exhibited in the Renault showroom.
- 2 A minimum distance of 1 m must be respected between the edge of the Duo Bento area and the Dacia showroom.
- 3 A minimum distance of 0.6 m must be respected between the back of the Duo & Bento area and the circulation aisle adjoining the common areas.



4.5

SALES OFFICES



## 4.5.1 Fundamentals

### **Generic implementation rule**

Renault sales offices are located in the rear part of the brand showroom. They are separated by the neutral circulation aisle.

The Dacia sales office is located in the brand exhibition area.

These offices are always arranged opposite the access doors of the respective showrooms.

### **Possible adaptation**

It is possible to integrate a Renew and/or Renault Pro+ sales office at one end of the closed office block.

### **Don't**

Renault sales offices cannot be set up separately from the Dacia showroom.

Merchandising furniture cannot be used to separate the 2 showrooms.

## 4.5.2 Integration of Renault sales offices



### PRINCIPLES

Renault sales offices are located on the edge of the Renault showroom in order to optimize the presentation of vehicles in the showroom.

- 1 Sales offices are grouped and located in alignment forming the background of the Renault showroom.
- 2 A circulation aisle with neutral tiling separates the sales offices from the Renault showroom.

### 4.5.3 Integration of Dacia sales offices

#### PRINCIPLES

We will favor the Dacia sales office at the heart of the dealership, visible from the entrance and from the Welcome area (Dacia & me). It is oriented obliquely at 45° in relation to the facade.

The layout components are standard.

1. We will favor an orientation that will allow the sales advisor to have a view of the dealership and avoid potential reflections on the screen.
2. A Welcome area directly accessible from the entrance is present in the center of the Dacia showroom. It is a reception area but also an informal exchange area between the Sales Advisor and the customer.

Customers wait for after-sales operations in the shared waiting lounge.



2

1

5

COMMON AREAS

5.1

WAITING LOUNGE

## 5.1.1 Fundamentals

### **Generic implementation rule**

Waiting lounge is accessible to Renault & Dacia customers. It has a neutral visual universe unrelated to the universes of the 2 brands.

It is located in the background of the showrooms on which it is open and adjoins the service reception.

It is backed by the after-sales area allowing customers to see their vehicle during work.

### **Possible adaptation**

Different configurations are possible in order to adapt the reception capacity to each site, based on a minimum depth of 4 m.

### **Don't**

Waiting lounge cannot be closed.

It must remain open to the showrooms in order to invite waiting customers to browse the exhibition areas.

## 5.1.2 Presentation

### PRINCIPLES

**Waiting lounge allows after-sales customers and customers waiting to take charge of their vehicle to wait in a warm environment.**

- 1 The layout codes are neutral, with no brand identity signs present in this common area.
- 2 A circulation path with neutral tiling connects this space to the Renault & Dacia brand showrooms.
- 3 A glass section allows customers to see the vehicles being serviced
- 4 Waiting lounge is adjacent to the service reception. It is separated from it by a full-height glass partition.



### 5.1.3 Standard configurations

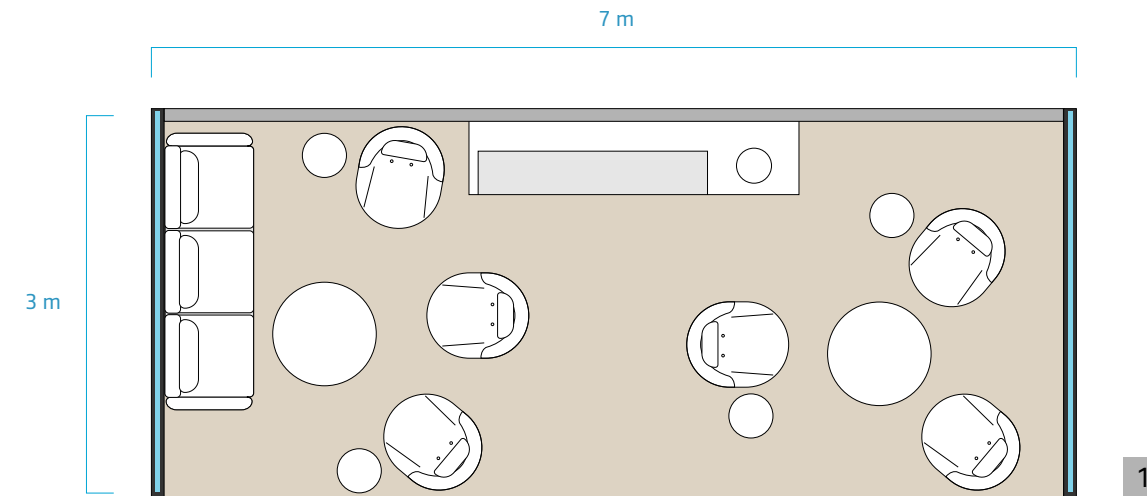

#### PRINCIPLE

2 standard formats are defined in order to meet the different implementation constraints including the following areas:

- relaxation area,
- co-working area,
- beverage area,
- entertaining area.

1 21 m<sup>2</sup> format

2 45 m<sup>2</sup> format



## 5.1.4 Variations of the 21 m<sup>2</sup> configuration

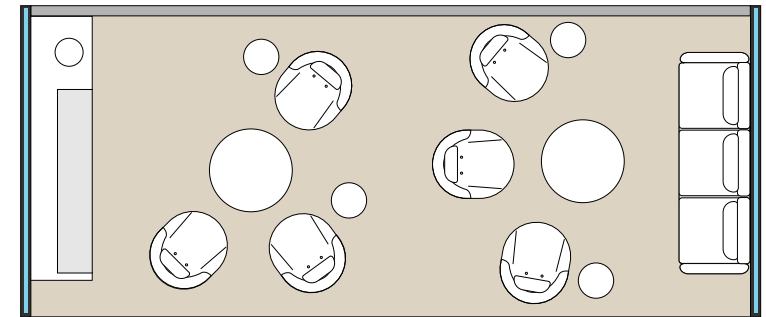
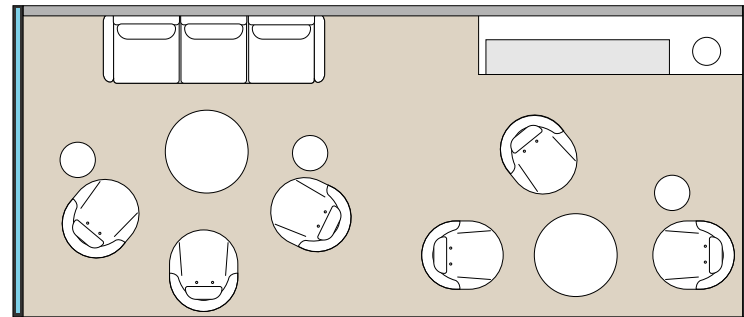
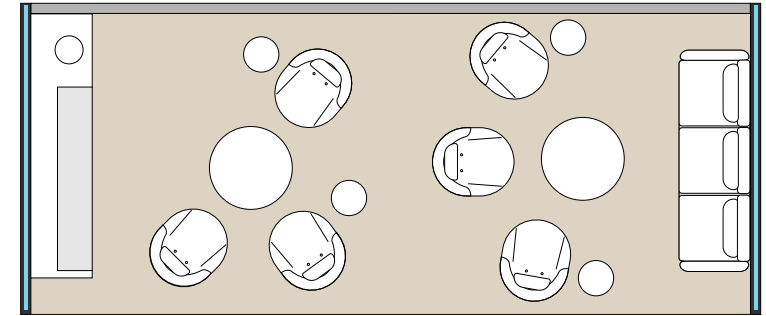
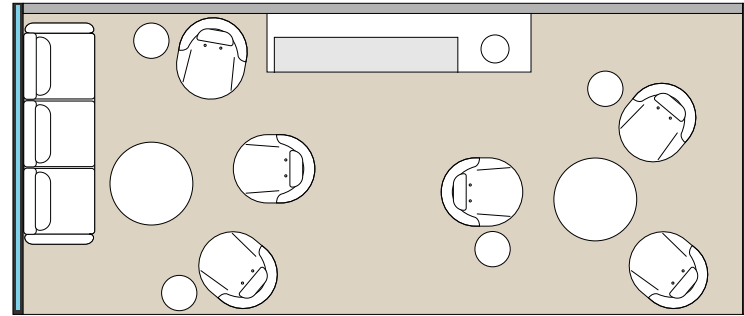

### MODULAR LAYOUT

Different layout options are possible, allowing up to 9 people to be accommodated.

## 5.1.5 Variations of the 45 m<sup>2</sup> configuration

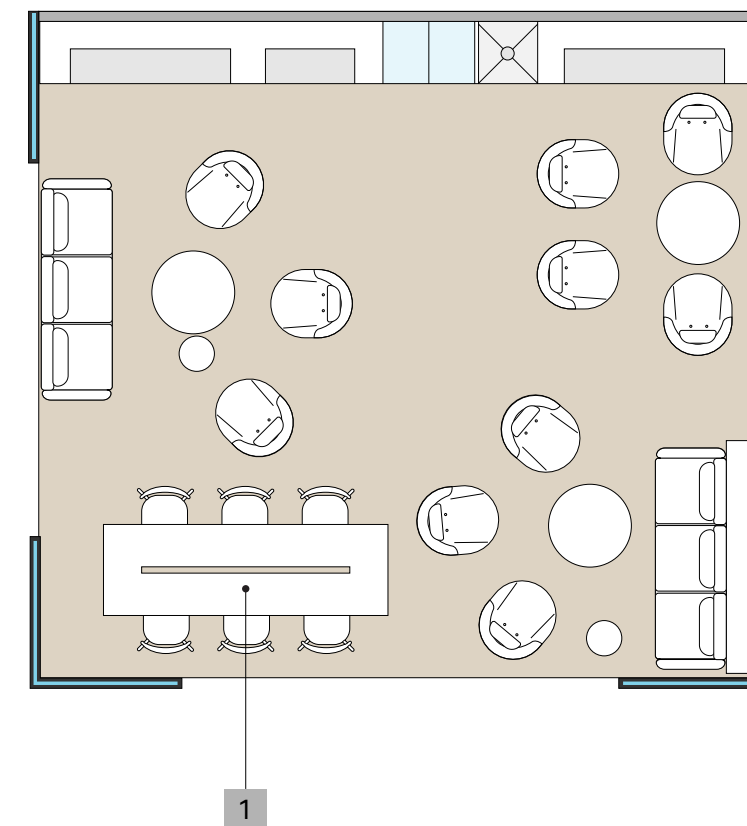
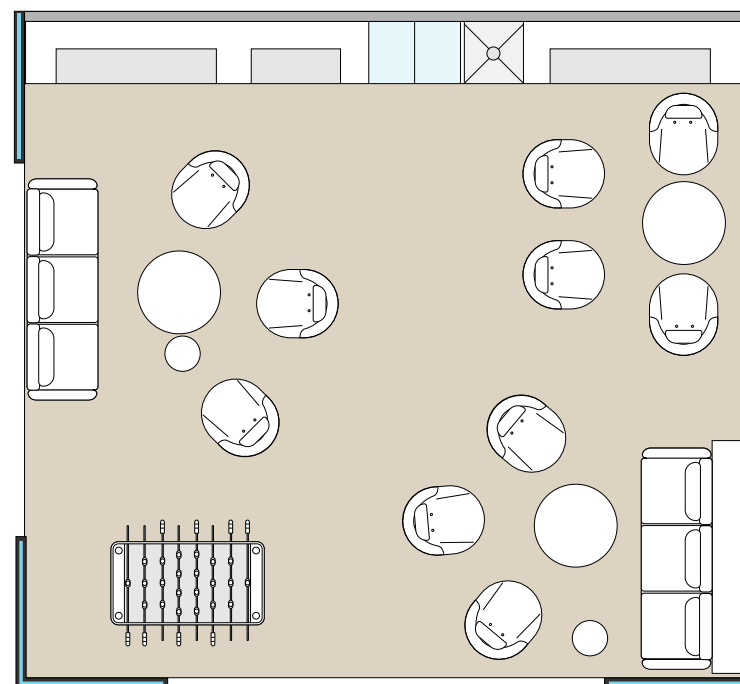

### MODULAR LAYOUT

Different layout variants are possible, allowing up to 16 people to be accommodated.

- 1 A co-working table can increase this capacity to 22 people.

5.2

CARE SERVICE RECEPTION

## 5.2.1 Fundamentals

### **Generic implementation rule**

The after-sales reception is common to the 2 brands present on the site.

The brands are present on the wall of this space in a similar way to that used for the identification of common workshop bays.

A Mobilize location customer reception can be integrated into this space according to different modalities.

### **Possible adaptation**

Renault furniture, composed of reception and storage modules, is used and allows different configurations adapted according to the number of service advisors.

### **Don't**

Configurations with separate receptions by brand are to be avoided.

## 5.2.2 Presentation

### PRINCIPLES

Care service reception is integrated into the background of the showrooms in the form of an open space welcoming the after-sales customers.

- 1 Back wall is white.
- 2 A part painted in dark grey includes the identification of this space, the signatures of the Renault & Dacia brands.
- 3 As an option, a screen presents to customers the schedule of interventions and their state of completion.
- 4 Floor receives a neutral treatment common to the shared spaces including the circulations.
- 5 Reception furniture modules (with storage furniture) are common to both brands. A customization of the activity of each counter is possible.
- 6 A full-height glazed part visually links the service reception to the after-sales space.
- 7 Ceiling is painted in matt black

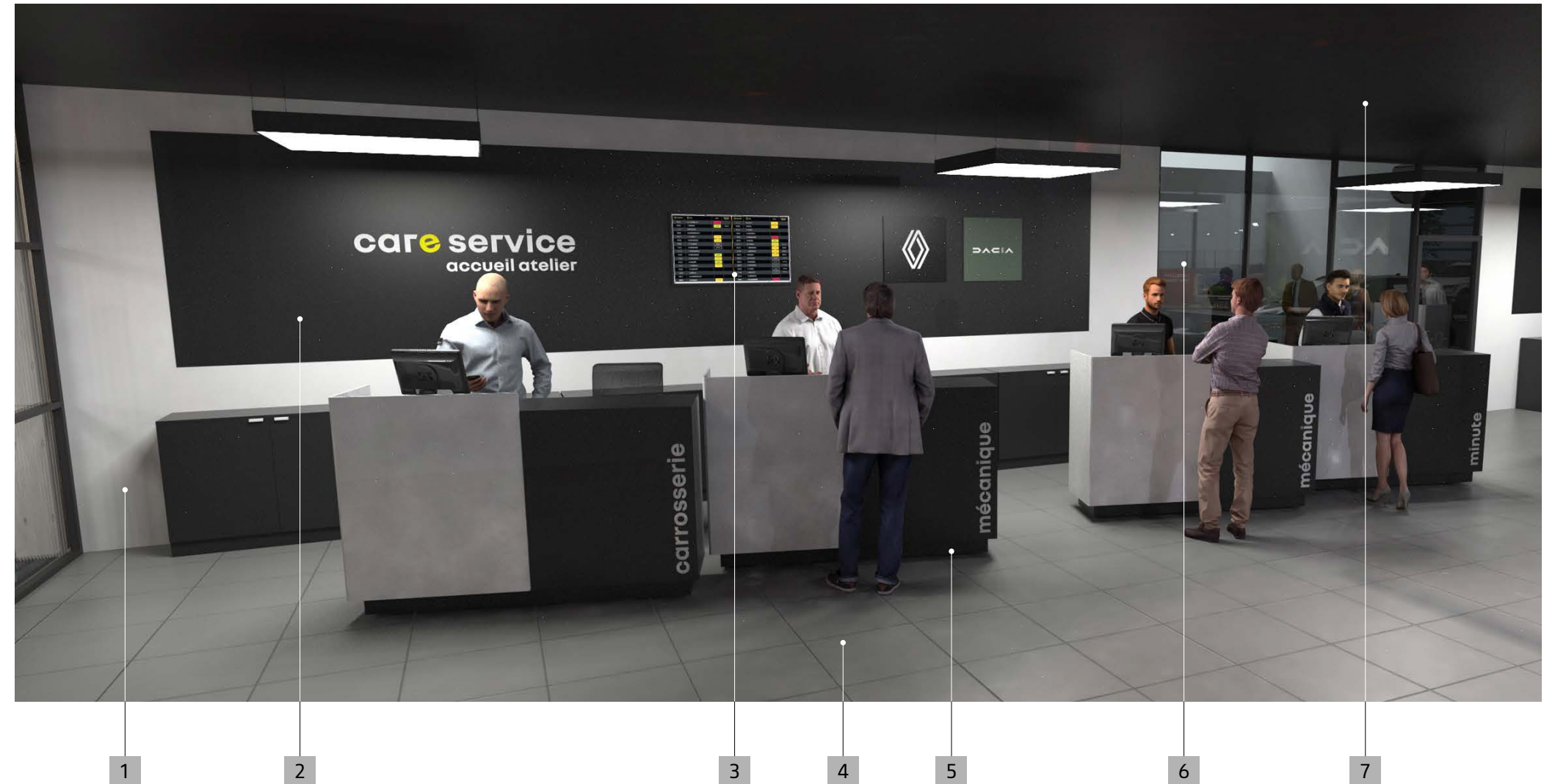

## 5.2.3 Description

### DESCRIPTION

- 1 Dark grey wall RAL 7021 matt finish, (canvas or fine texture paint for easy cleaning),
- 2 Texts "care service" and "accueil atelier" in Renault Group Bold typography, white and yellow matt adhesive, aligned to the right.
- 3 After-sales reception furniture.
- 4 43" video screen installed in the central part of the wall.
- 5 Matt black square RAL 9005 with white Renault diamond, matt adhesive finish.
- 6 Khaki square pantone 5615 C with Dacia logo in white, matt adhesive finish.
- 7 Possible extension of the length of the dark grey wall.

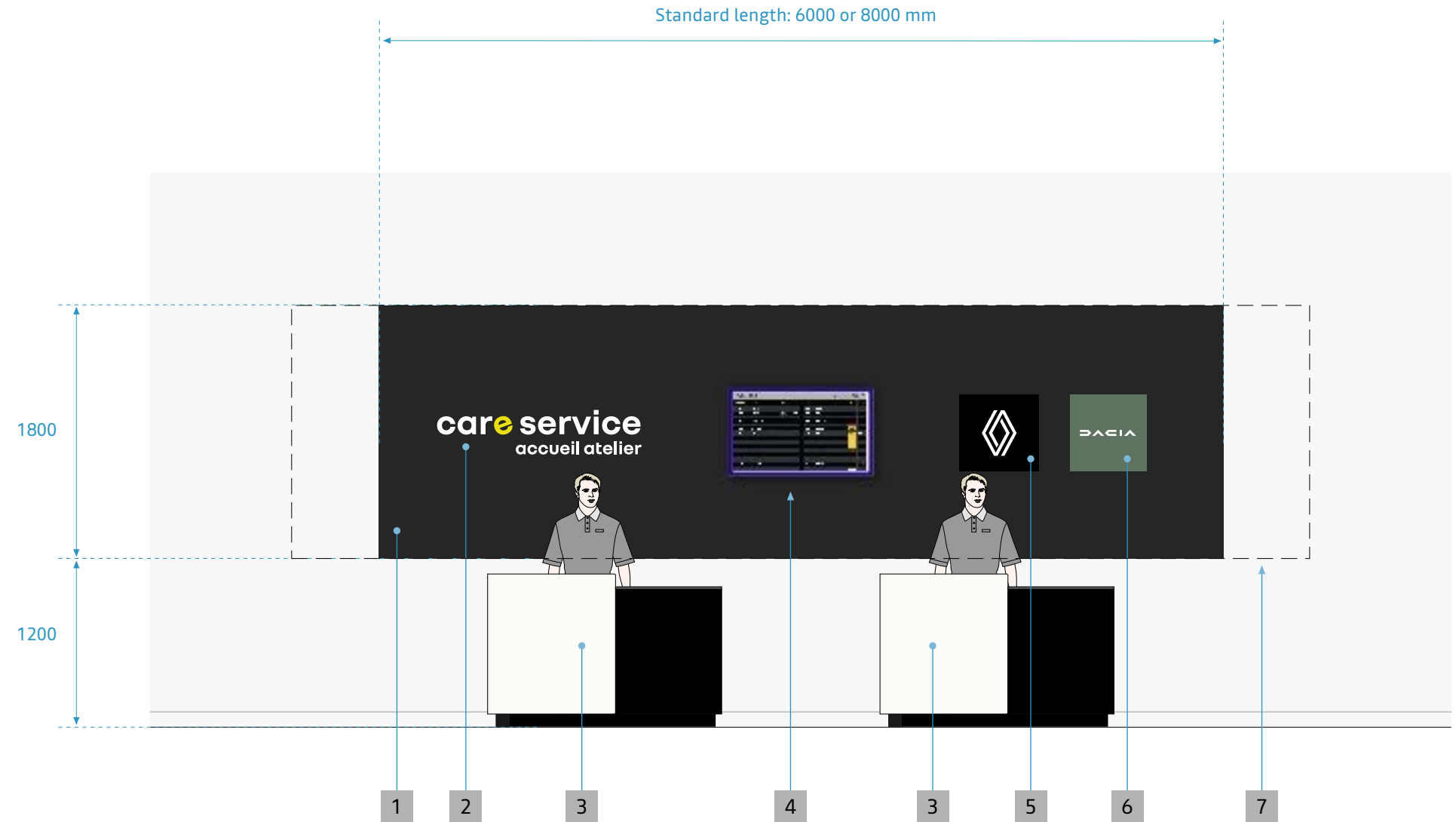

## 5.2.4 Variations

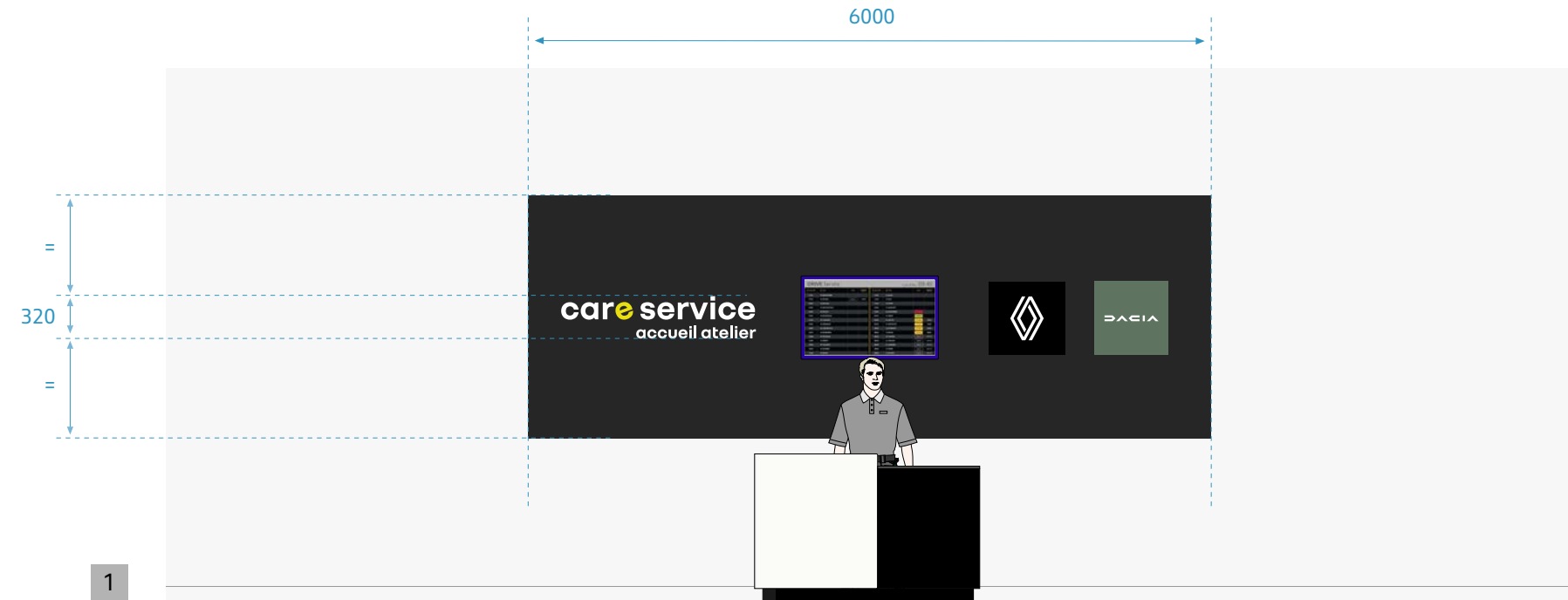

### PRINCIPLES

The adaptation to the number of advisors is done by:

- the extension of the length of the dark grey wall.
- the number of furniture modules.
- the distances between the components on the dark grey wall are always the same regardless of the total length of the wall.
- the adjustment to the length of the dark grey wall is also done on either side of the central part of 4000 mm.

1 Configuration with Single Service advisor.

2 Extended configuration.

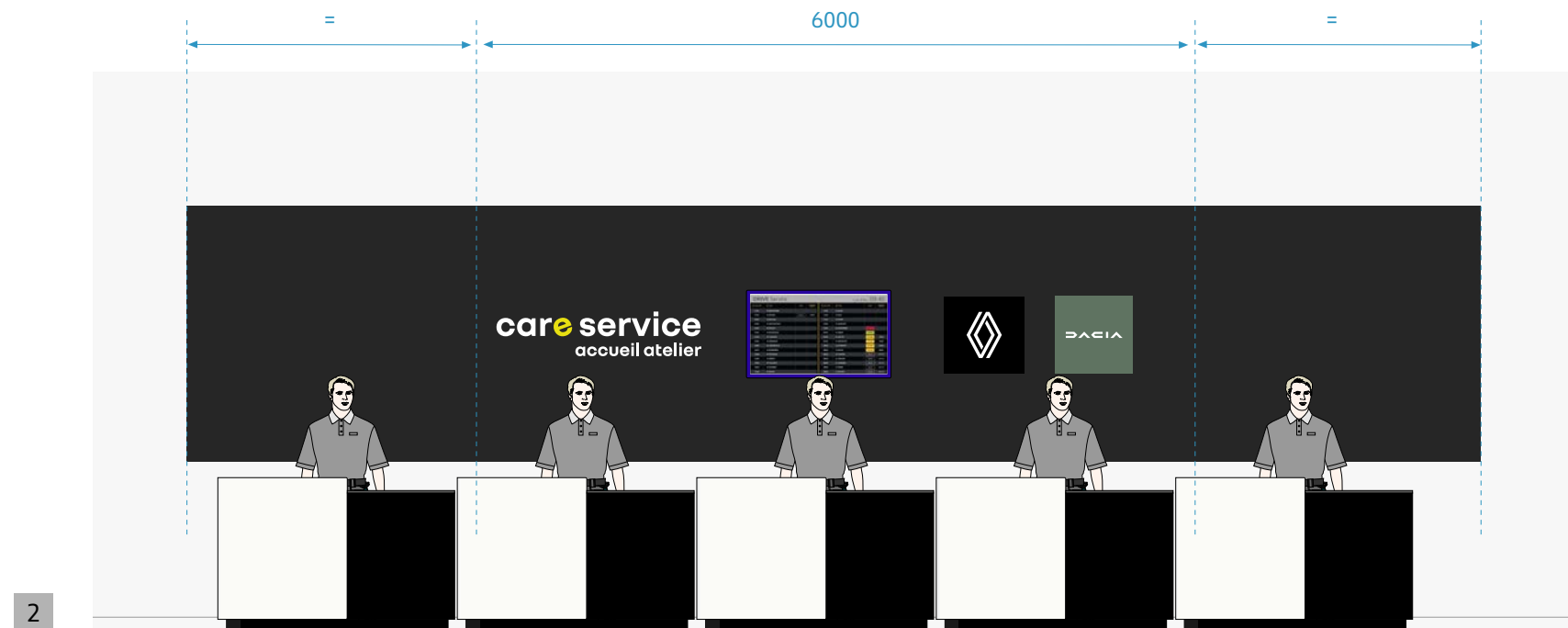

## 5.2.5 4 m wall

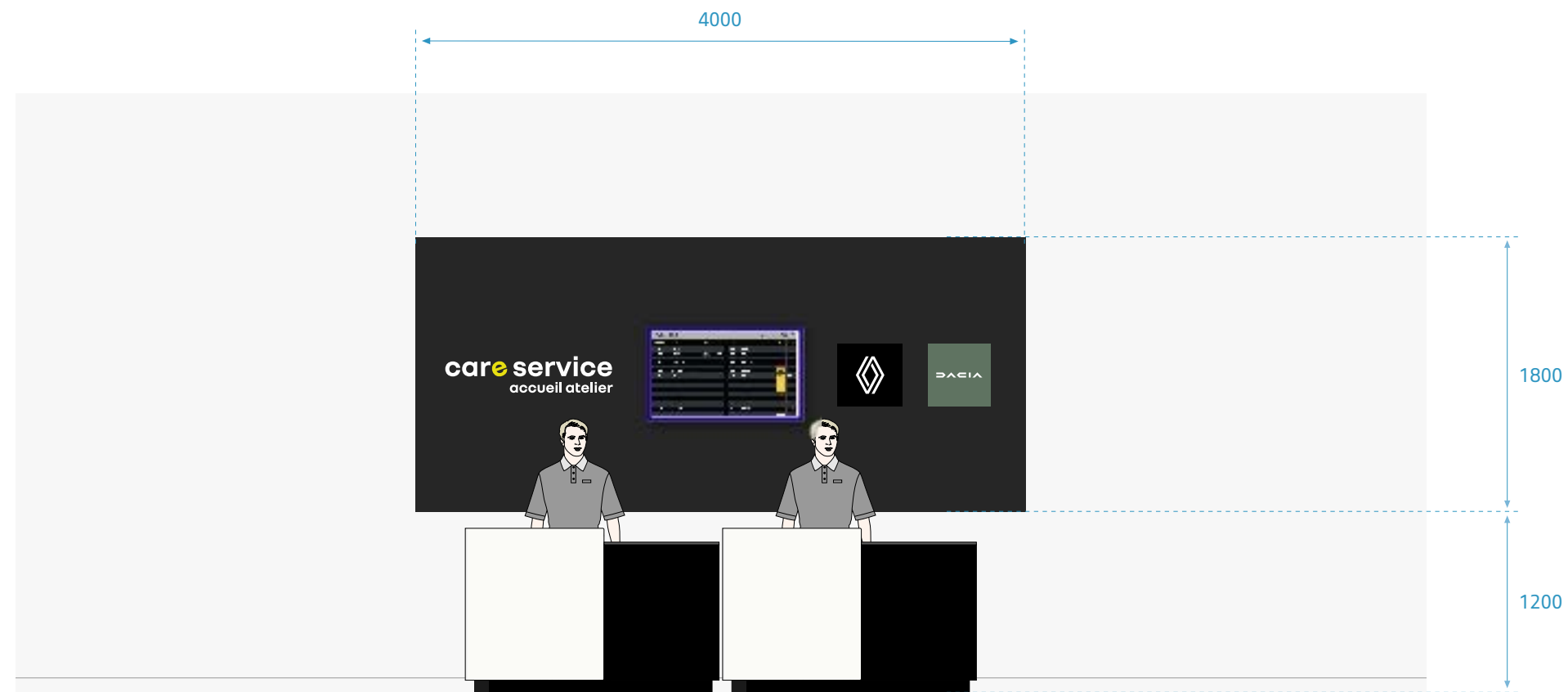

### ADAPTATION PRINCIPLES

- Adapted dimensions of lettering and plates compared to standard configurations.
- Constant proportions between graphic elements.
- Standard size of the 43-inch video screen.



## 5.2.6 3 m wall

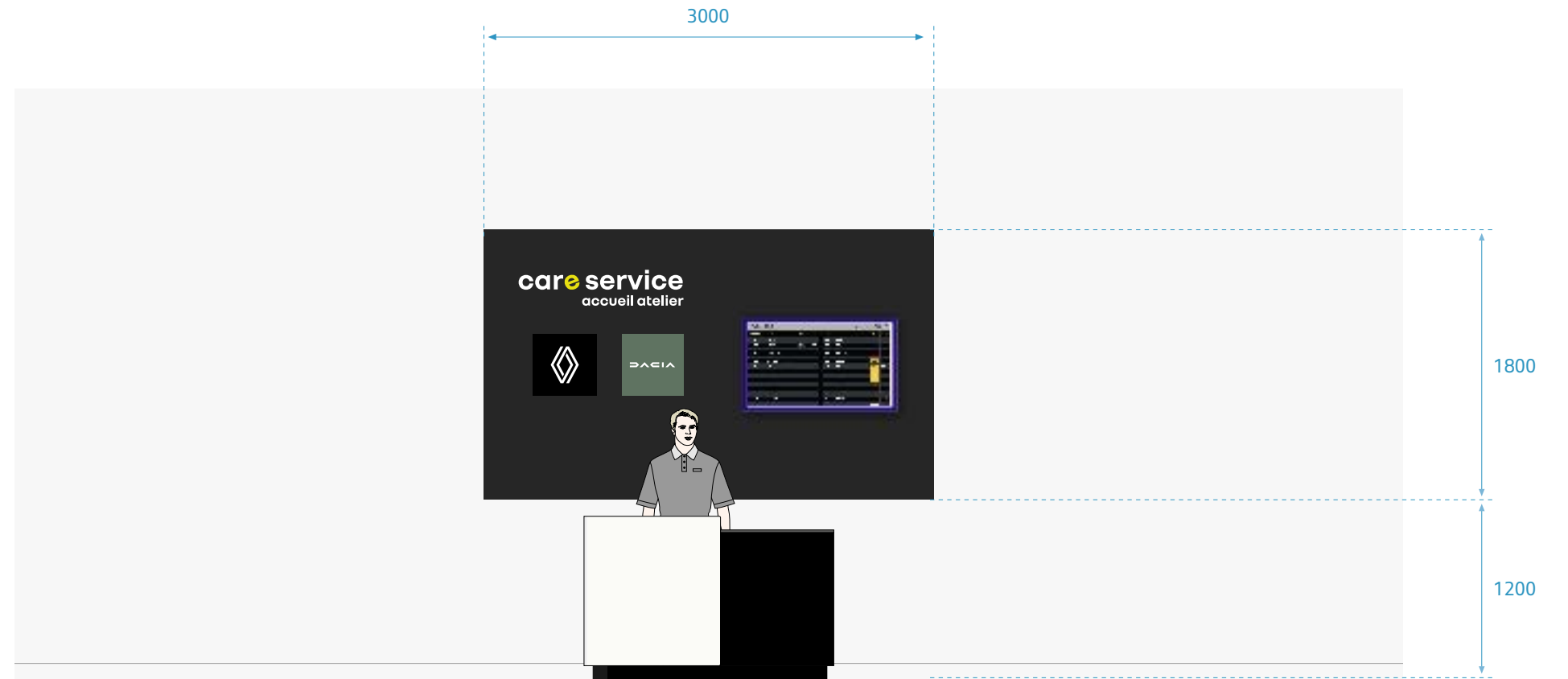

### ADAPTATION PRINCIPLES

- The dimensions of the lettering and plaques are the same as for a 4 m wall.
- Constant proportions between the graphic elements.
- Standard size of the 43-inch video screen.

## 5.2.7 Mobilize share reception

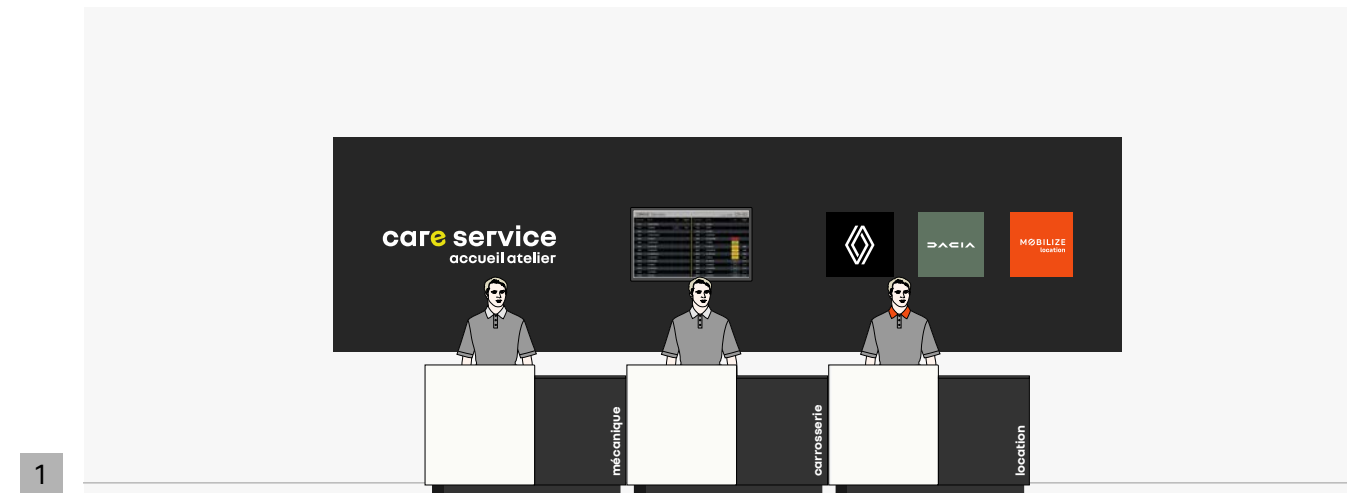

### GENERIC PRINCIPLE

- 1 The Mobilize share reception can be integrated into the care service reception. It is identified by a wall plaque and the marking of the reception furniture dedicated to Mobilize customers.
- 2 The Mobilize share reception can be separated from the care service reception but present in the same space. It is identified by a wall plaque on a dark grey background similar to the care service reception and a marking of the reception furniture dedicated to Mobilize customers. A minimum distance of 1 m is required between the 2 wall frescoes.

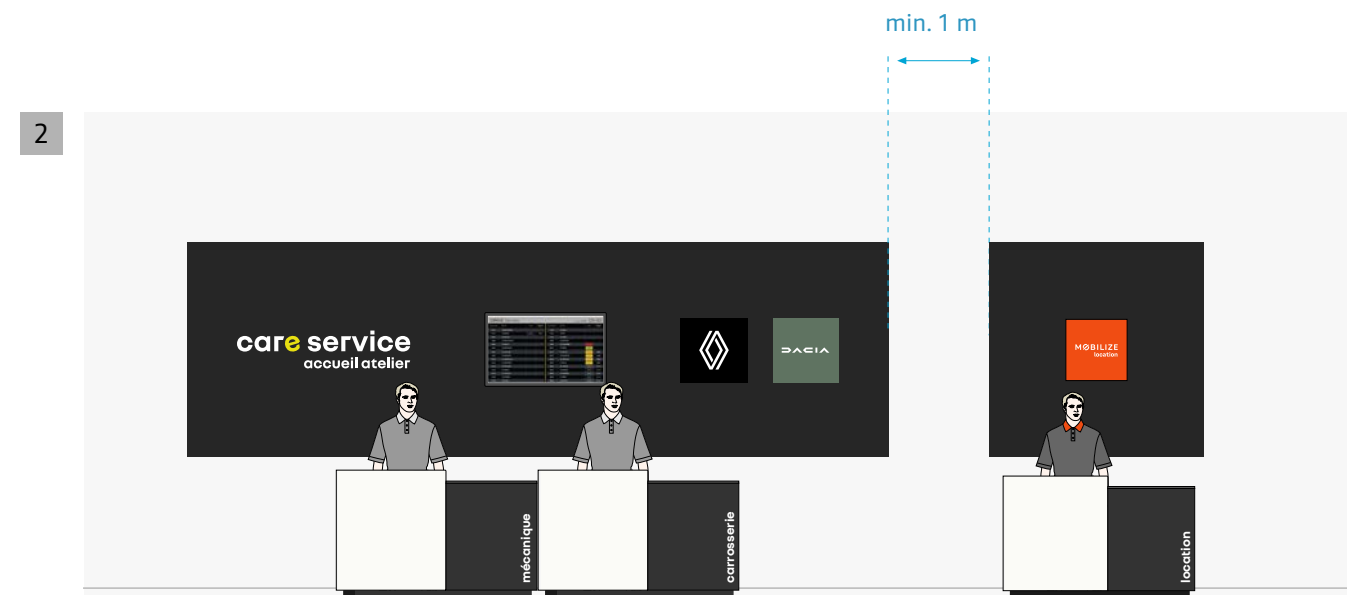

## 5.2.8 Main prohibitions

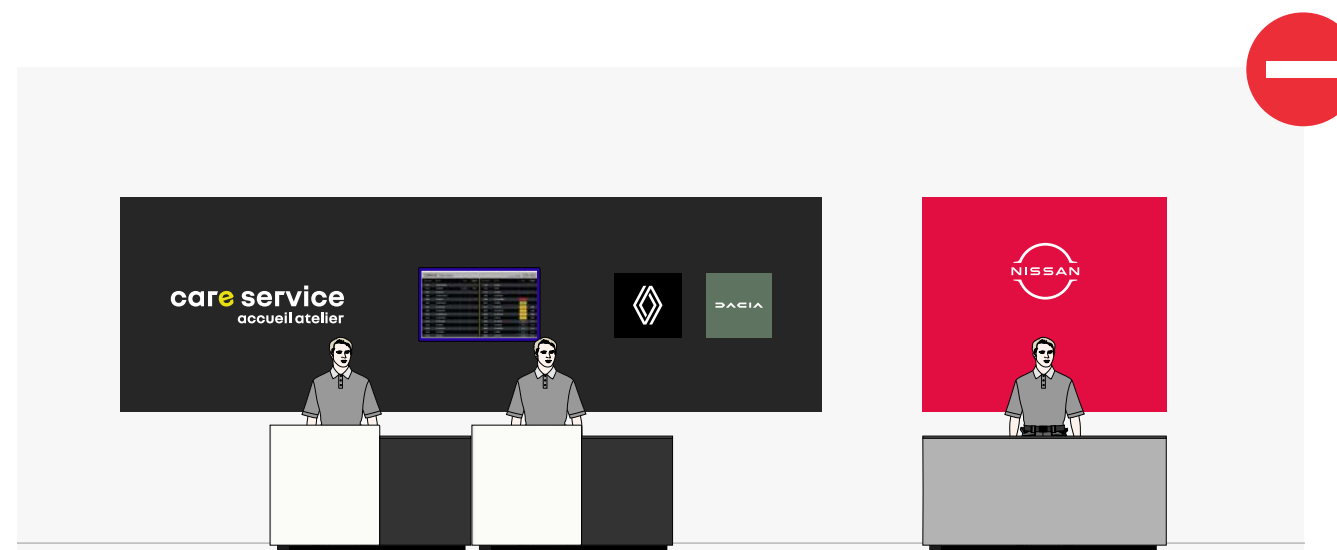
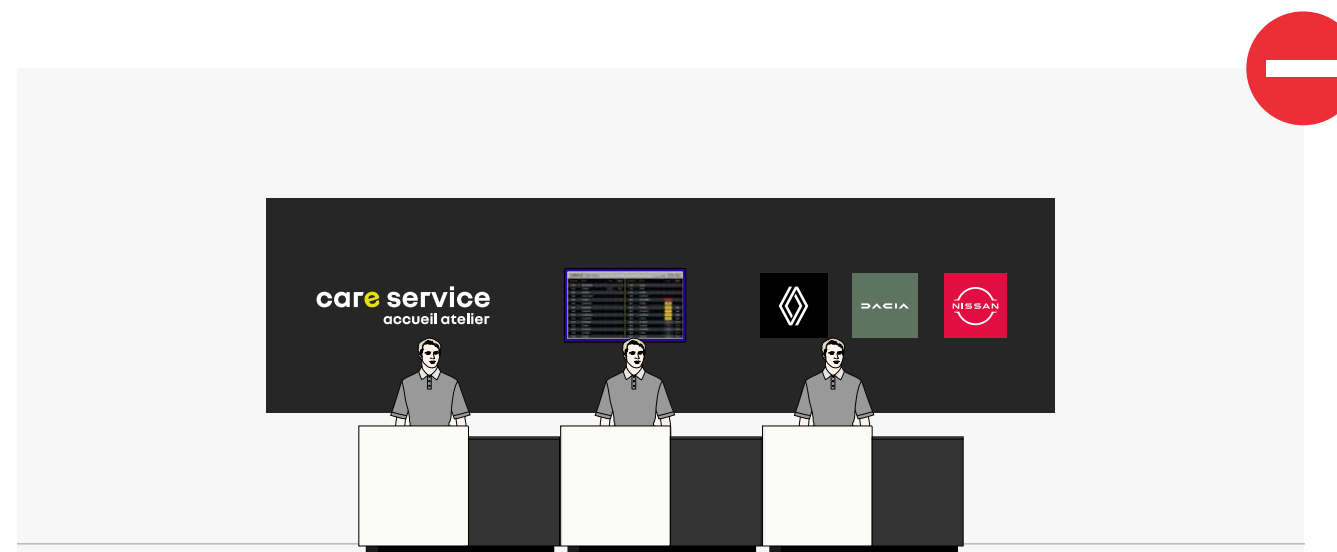

### MAIN PROHIBITIONS

- 1 Integration of another brand identity outside Renault Group in the service reception wall fresco.
- 2 After-sales reception of brands outside Renault Group in the same area.

5.3

DELIVERY AREA

## 5.3.1 Fundamentals

### **Generic implementation rule**

The delivery is a decisive moment that must be the subject of particular attention in the context of the delivery of a vehicle or in the case of the presentation of a vehicle for testing.

In the context of a multi-brand site, this common area adopts specific markings and visuals allowing the delivery and presentation of Renault & Dacia vehicles (as well as the renewed vehicles benefiting from an extended warranty) in a neutral space.

Front-office space, it is preferably located behind the sales offices and has a link with the finishing area located in the workshop.

### **Possible adaptation**

Different configurations are possible depending on the desired capacity and the shape of the delivery area.

### **Don't**

Delivery area should never be installed in showrooms.

## 5.3.2 Presentation

### PRINCIPLES

The delivery of vehicles and the rapid presentation of vehicles during a test drive, takes place in the delivery area.

- 1 The walls of this area are matt white.
- 2 A visual identifies the area. It includes a large format visual.
- 3 The vehicle covers are signed by the brands. These are the only identifying elements present in this shared area.
- 4 The lift-up doors are painted dark grey. They are mostly glazed for those that allow the exit and lightly glazed for the one that connects the handover area to the back office finishing area.
- 5 The floor receives a neutral treatment common to the shared areas including the circulations.
- 6 The delivery advisor's office is neutral (devoid of brand identity signs). Customers come there to complete the administrative formalities before being invited to handover their vehicle.



### 5.3.3 Visual

#### GENERAL

The visual identifies the area.

In this configuration, only new vehicles of the Renault & Dacia brands as well as used vehicles of all brands can be delivered to this space.

#### IDENTIFICATION PRINCIPLES

The proportions between the dark grey rectangle and the visual are different depending on the length of the wall.

The maximum length of the visual is limited to 6 m.

The typography used is Renault Group Bold.

- 1 Wall length < 10 m
- 2 Wall length from 10 to 20 m
- 3 Wall length > 20 m

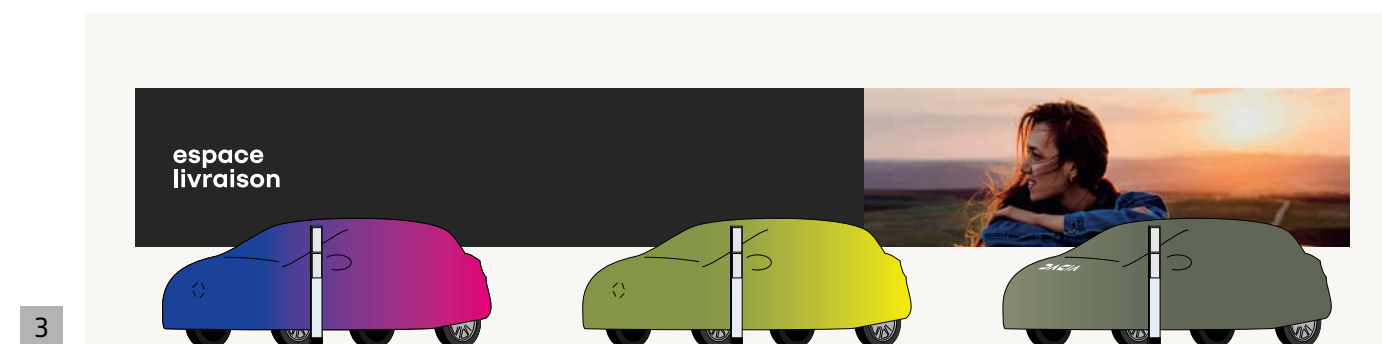
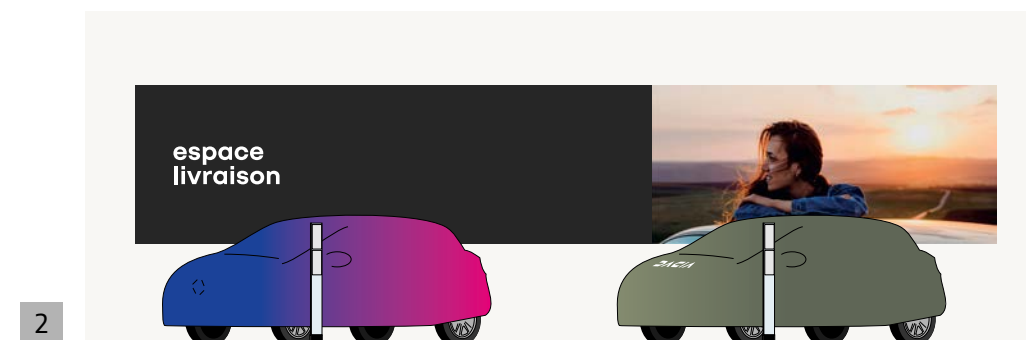

### 5.3.4 Adaptation of visuals according to the direction of exit of vehicles



#### ADAPTATION PRINCIPLES

Depending on the position of the vehicle exit door, the order of the visuals should be reversed.

The marking is always positioned as close as possible to the exit door.

1. Order of the visuals in the case of a vehicle exit door located to the left of the back wall of the Delivery area.
2. Order of the visuals in the case of a vehicle exit door located to the right of the back wall of the Delivery area.

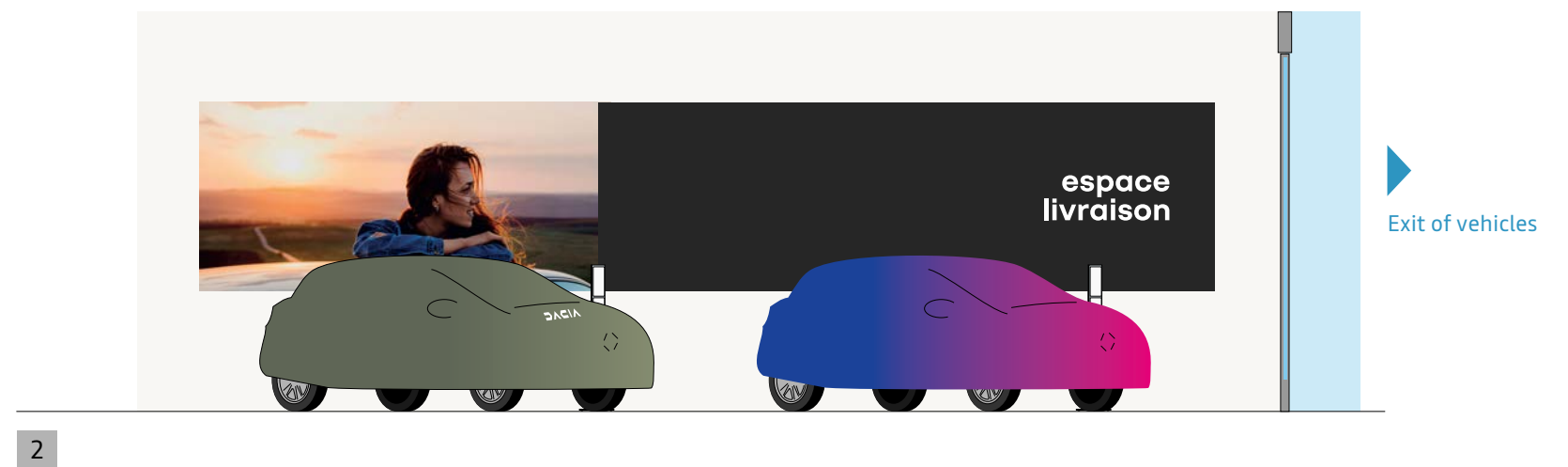



### 5.3.5 Generic layout

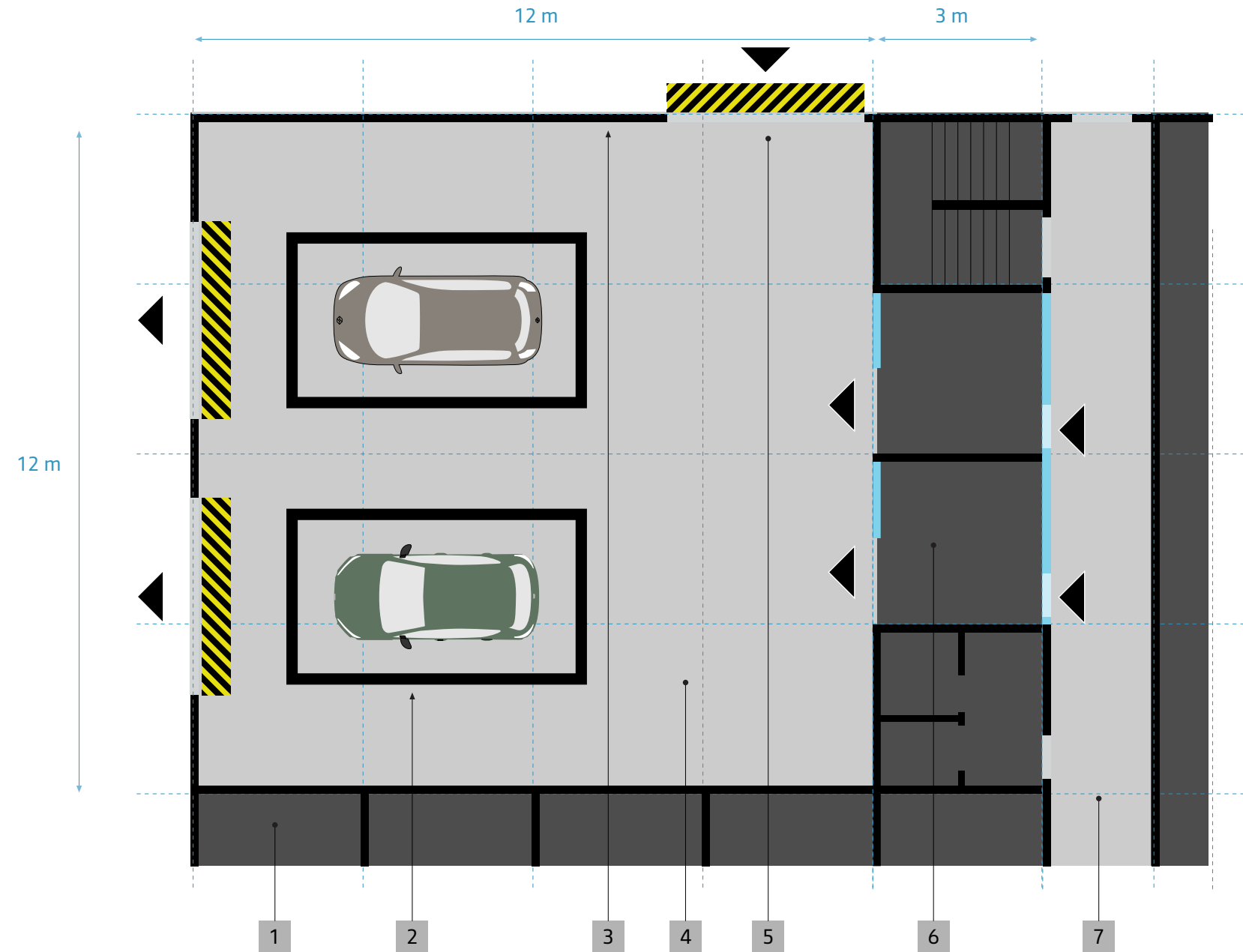

#### IMPLEMENTATION PRINCIPLES

Vehicles leave the back-office finishing area to be presented in the handover area.

In this area, vehicles are carefully aligned in front of the exit doors to allow customers to leave this area easily and safely.

- 1 Sales offices
- 2 Lighting.
- 3 Wall fresco
- 4 Tiles or resin.
- 5 Access door from the back-office workshop.
- 6 Delivery advisor's office.
- 7 Traffic aisle.

## 5.3.6 Delivery advisor's office



### PRINCIPLES

The delivery advisor's office is neutral (devoid of brand identity signs).

- 1 White wall.
- 2 Furniture to Renault Group standards.
- 3 Dark grey carpet.
- 4 Renault Group wall visuals.

1 2 3 4

# 5.4

## DIRECTIONAL SIGNAGE

## 5.4.1 Fundamentals

### **Generic implementation rule**

Directional signage marks out customer journeys when the different spaces are not in the same volume or building.

At the service reception, signage can be used to identify counters when service advisors are dedicated to different activities (mechanics, bodywork, minute, rental, etc.).

### **Possible adaptation**

Different wall or suspended supports meet the variety of implementation cases.

### **Don't**

Directional signage must never integrate the graphic codes of one of the brands.

## 5.4.2 Directional signage wall mounted

### GENERIC PRINCIPLE

The directional information is collected and positioned on the walls of the showroom.

**Depending on visibility conditions, the directional signage can be made in white letters on a dark grey background or black letters on a white background.**

The text block is installed 1700 mm from the ground.

- 1 Dark grey vertical strip RAL 7021 in matt finish made in paint.
- 2 White adhesive RAL 9003 in matt finish.
- 3 White wall RAL 9010 in matt finish.
- 4 Black adhesive RAL 9005 in matt finish.



### 5.4.3 Directional signage suspended

#### GENERIC PRINCIPLE

**Directional signage mural can be completed by suspended supports, installed at 2500 mm from the ground.**

These panels have a unique format of 300 x 1000 mm. They are made of aluminum sheet lacquered in RAL 7021 dark grey with a satin finish.

They can be double-sided.

A typographical variant must be taken into account depending on whether it is a Renault site or a multi-brand site.

- 1 RAL 7021 dark grey front face in matt finish with texts and arrows made of matt white adhesive.
- 2 Tubular brackets lacquered in RAL 9003 white, satin finish.

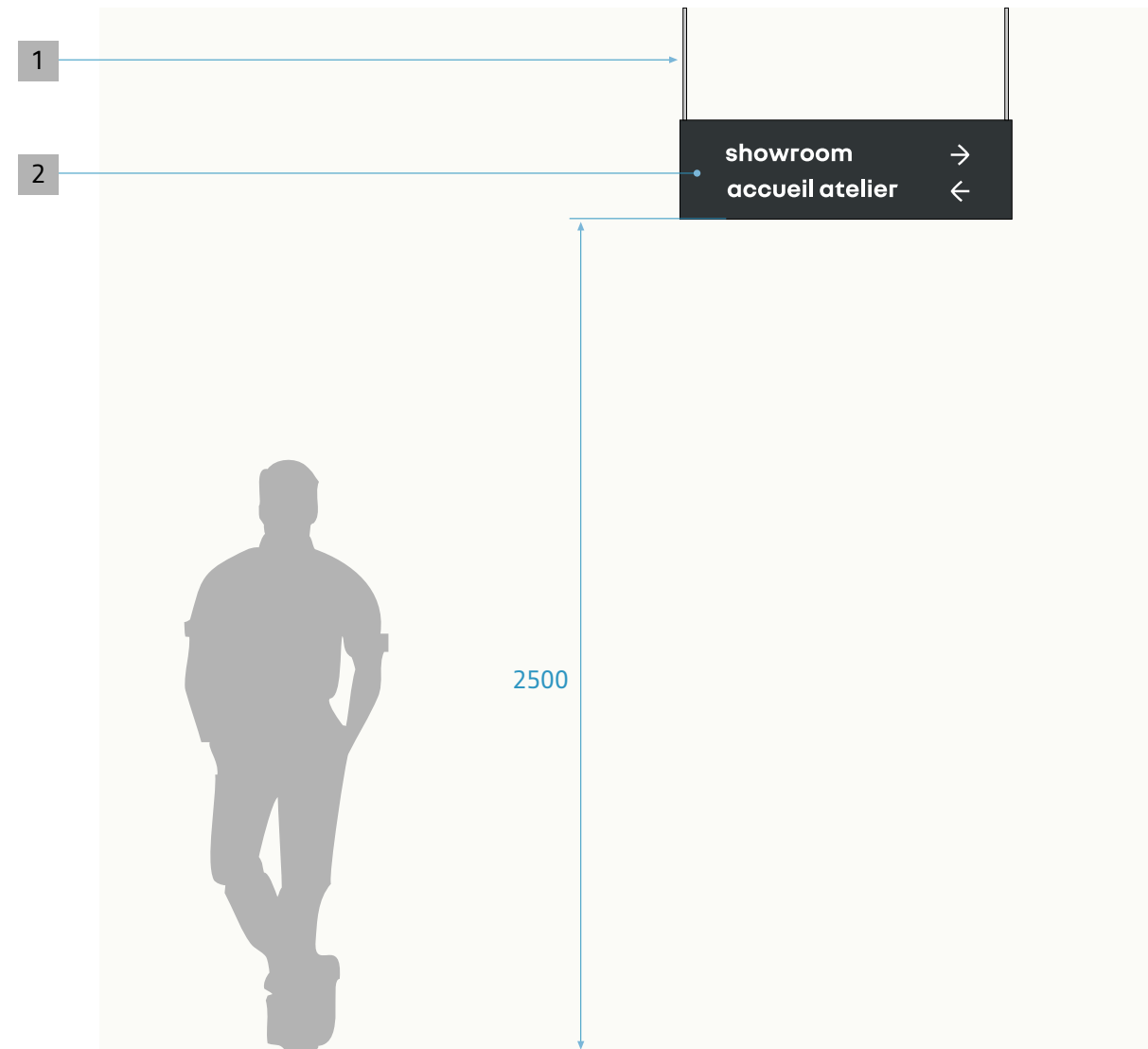

## 5.4.4 Pictograms

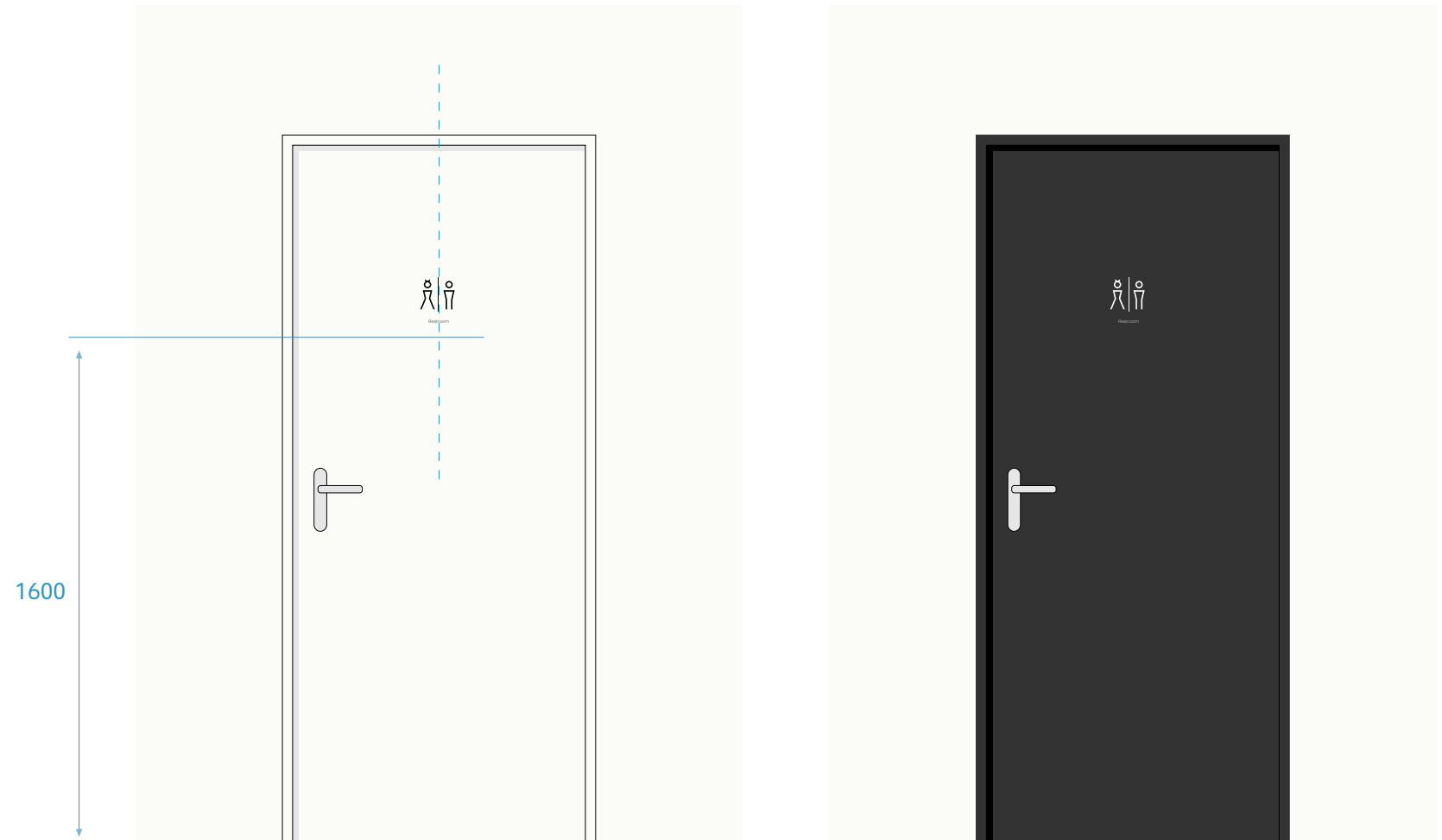
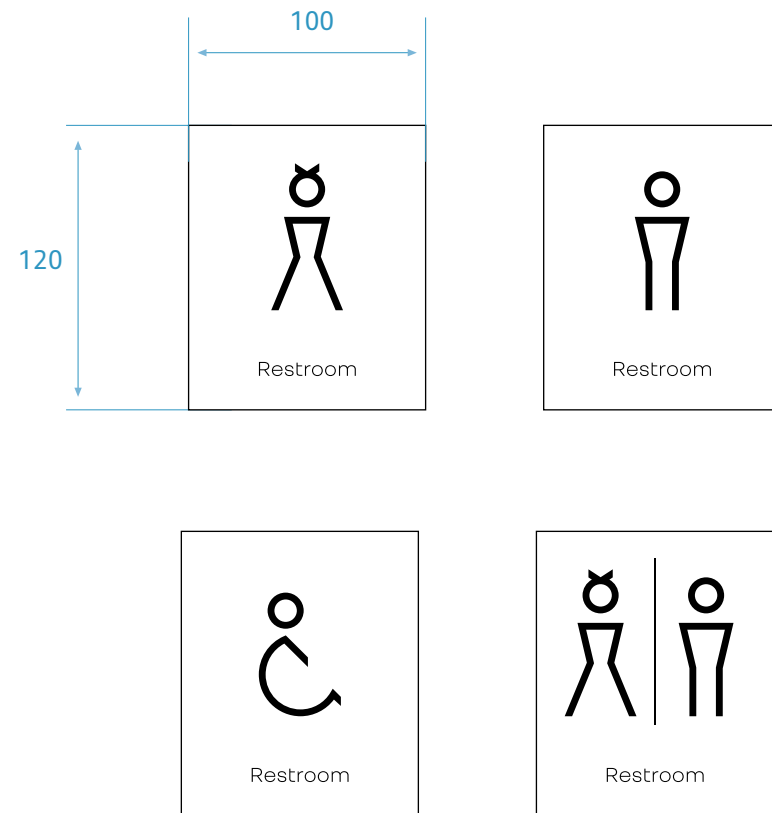

### PRINCIPLE

Unique pictogram format: 120 x 100 mm.

Black pictograms on white door or white pictograms on dark grey or black door made of adhesive with matt finish or 3 mm thick PMMA with laser cutting.

Typography: Renault Group Light.

## 5.4.5 Markings of the reception service furniture

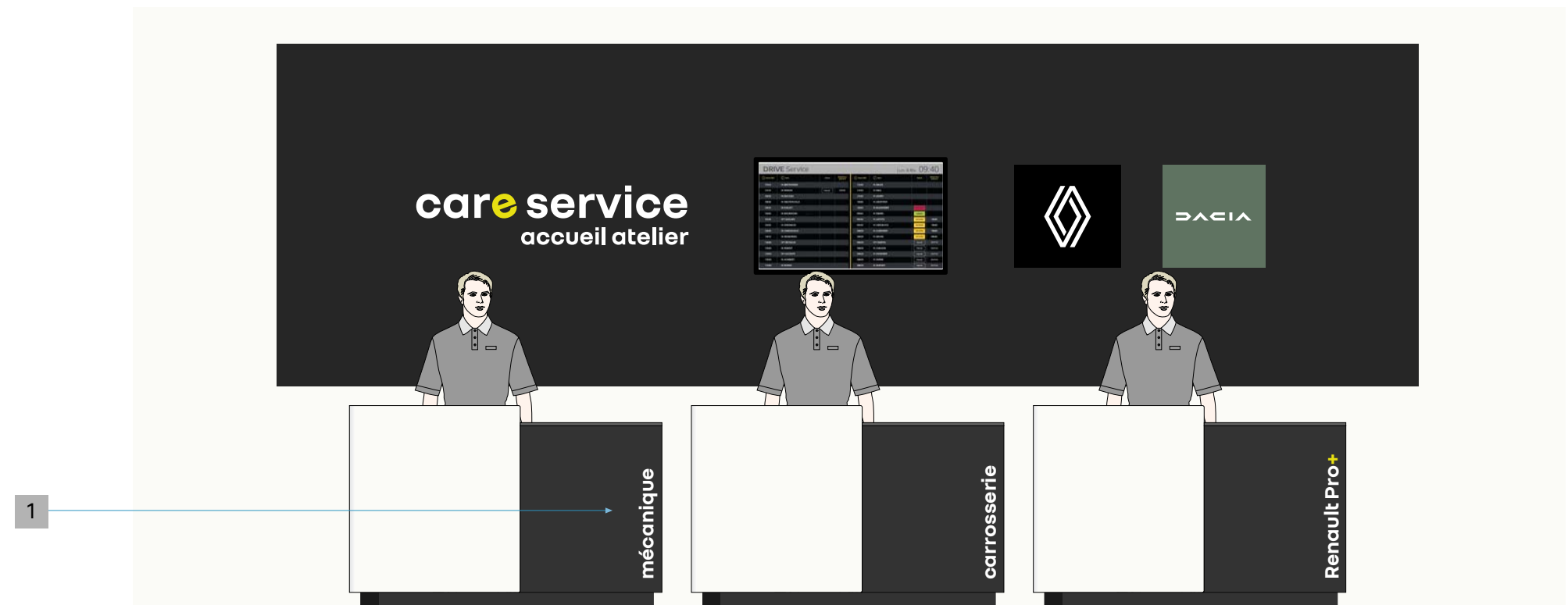

### GENERIC PRINCIPLE

In the case of advisors dedicated to an after-sales activity (mechanics, bodywork or Renault Pro+), the identification of the service reception counters is done by an adhesive marking positioned on the dark grey part.

1 Texts in matt white adhesive.



## 5.4.6 The integrated Mobilize share reception

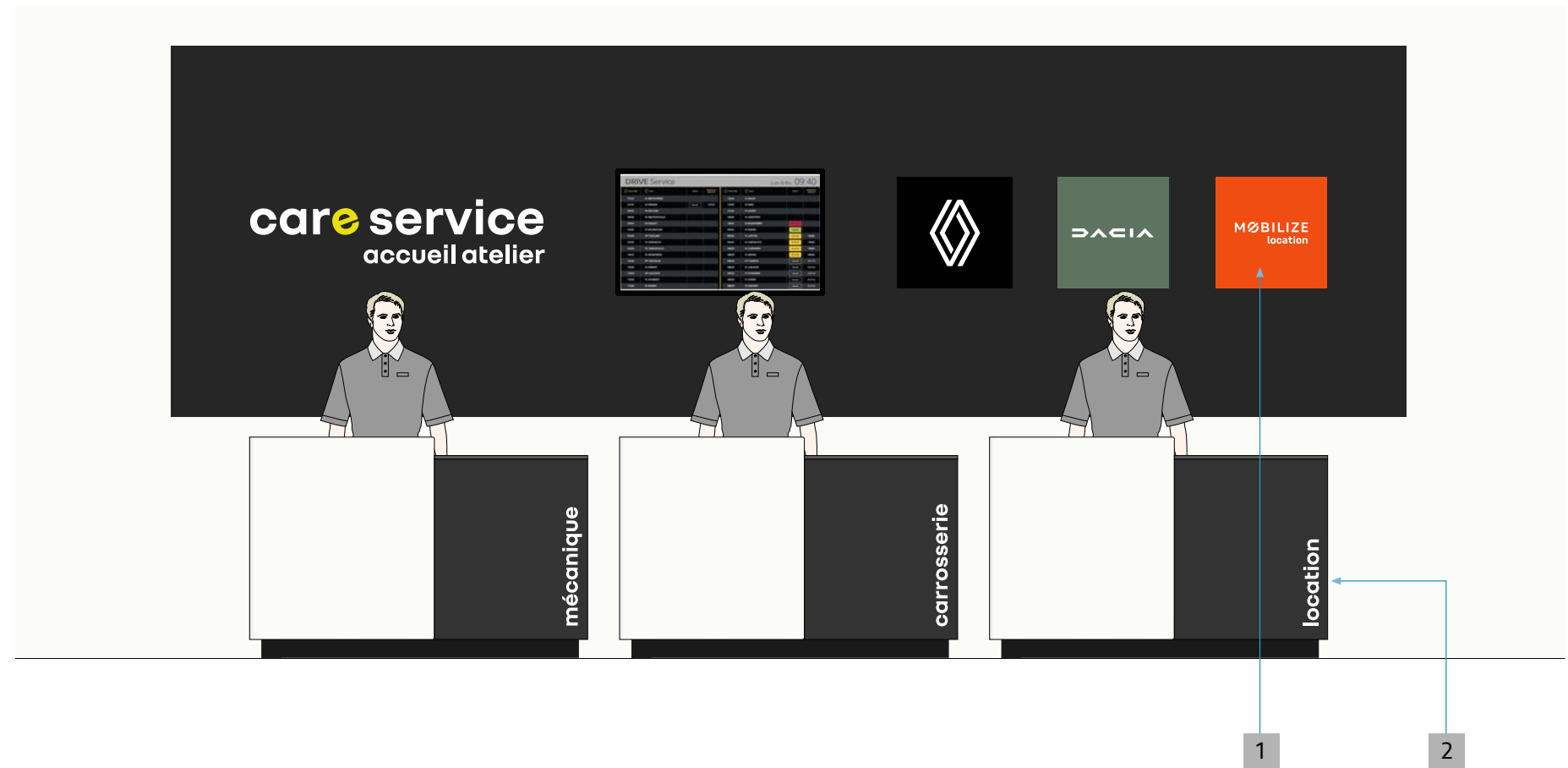

### IDENTIFICATION PRINCIPLE

The identification of the counter dedicated to the rental activity is done by an adhesive marking positioned on the dark grey part.

- 1 The Mobilize share wall plate.
- 2 "Location" text in matt white adhesive.  
Renault Group Bold typography.

## 5.4.7 The separate Mobilize share reception

### DESCRIPTION

The dedicated Mobilize reception is identified by a dark grey wall marking in a minimum format of 1800 x 1800 mm with the Mobilize logo on an orange plate.

The back wall of the reception is RAL 9010 white with a matt finish.

The reception furniture is common to Renault Dacia after-sales receptions.

It has a "rental" marking identifying the dedicated counter.

- 1 White RAL 9010 wall.
- 2 Dark grey RAL 7021 wall.
- 3 Mobilize wall plate 540 x 540 mm.
- 4 "location" text in matt white adhesive.  
Renault Group Bold typography.

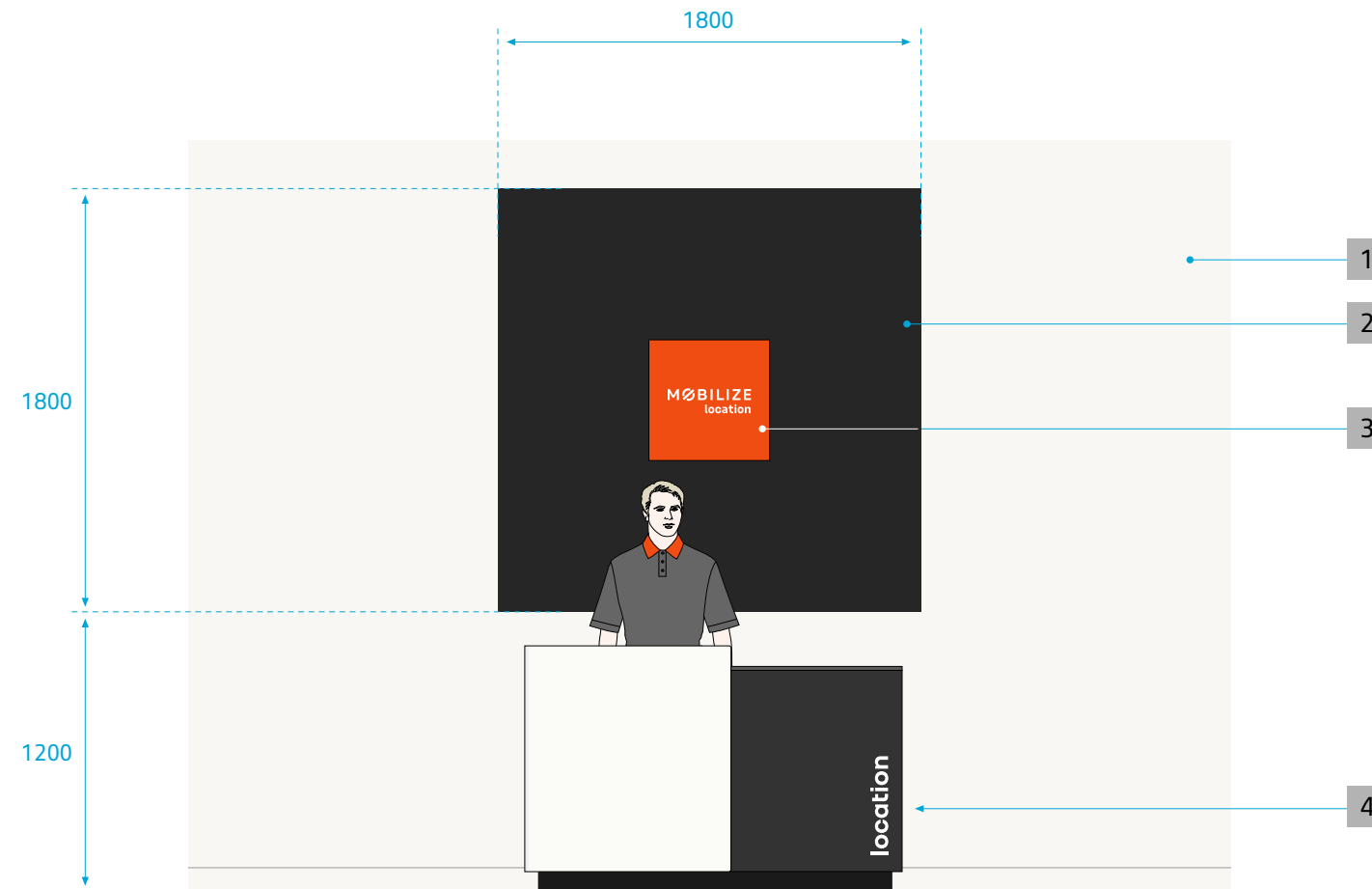

5.5

CIRCULATION AISLES

## 5.5.1 Fundamentals

### **Implementation rule**

Circulation aisles are a key element of the multi-brand concept: they connect the different common areas and contribute to the promotion of the brands.

### **Don't**

The direct juxtaposition of common areas with showrooms should be avoided.

## 5.5.2 General layout

### PRINCIPLES

**Circulation aisle connect the different outdoor areas to the building housing the showrooms and other functions of the site:**

- 1 Customers passing through the showrooms can reach the outdoor exhibitions renew and Renault Pro+.
- 2 From the service reception, after-sales customers can access the return parking lot.
- 3 From the service reception, after-sales customers can access the mobility service including replacement or rental vehicles.
- 4 After entering the showrooms, customers can access the service reception.
- 5 After entering the showrooms, customers can access the delivery area.

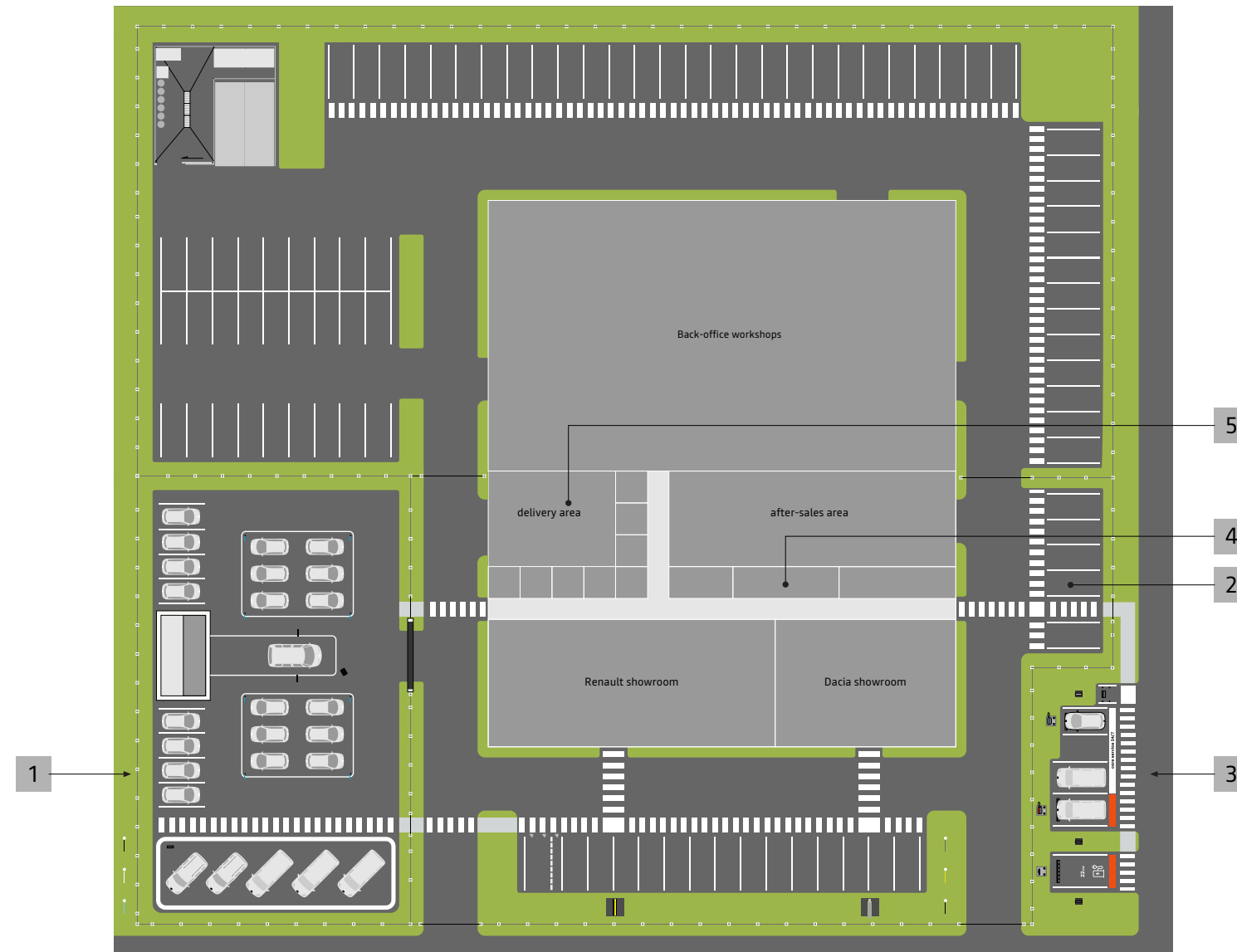

### 5.5.3 Connections with outdoor areas

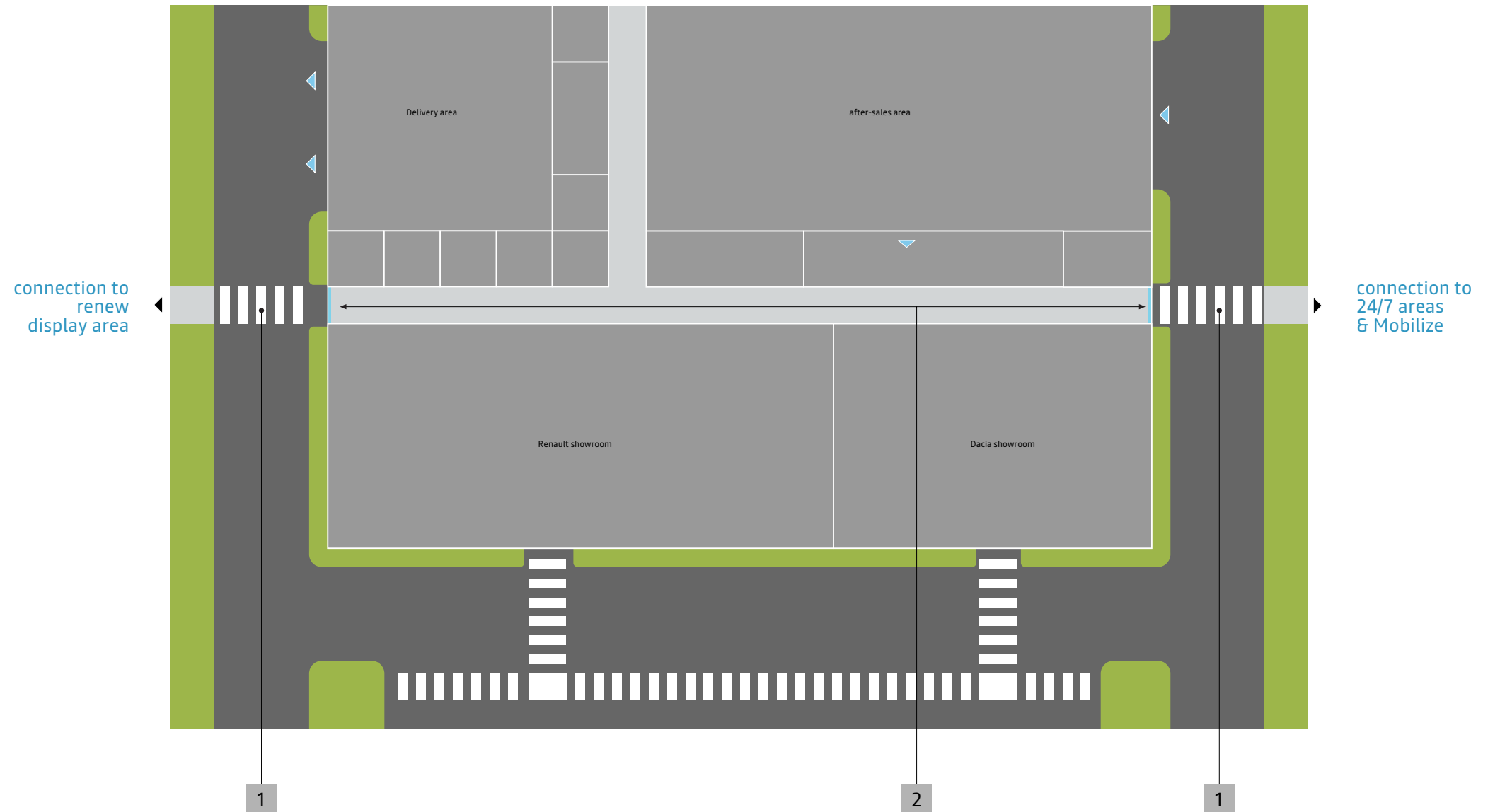

#### IMPLEMENTATION PRINCIPLES

The connections between internal functions and external spaces are based on the use of protected passages marking out customer paths and glass doors allowing visibility of these spaces from inside the building.

- 1 Pedestrian paths.
- 2 Glazed pedestrian doors.

## 5.5.4 Implementation in the building

### IMPLEMENTATION PRINCIPLES

Inside the building, the circulation aisle connects the showrooms to the common areas (lounge, handover area, service reception and toilets) while highlighting the showrooms, places where the brand universes are expressed.

The Renault sales offices (possibly Renew and Renault Pro+) are aligned with the other common areas.

The circulation aisle helps to provide greater confidentiality to exchanges.

- 1 Central circulation aisle.
- 2 Renault showroom.
- 3 Circulation aisle leading to the handover area.
- 4 Waiting lounge.
- 5 Service reception.
- 6 Dacia showroom.

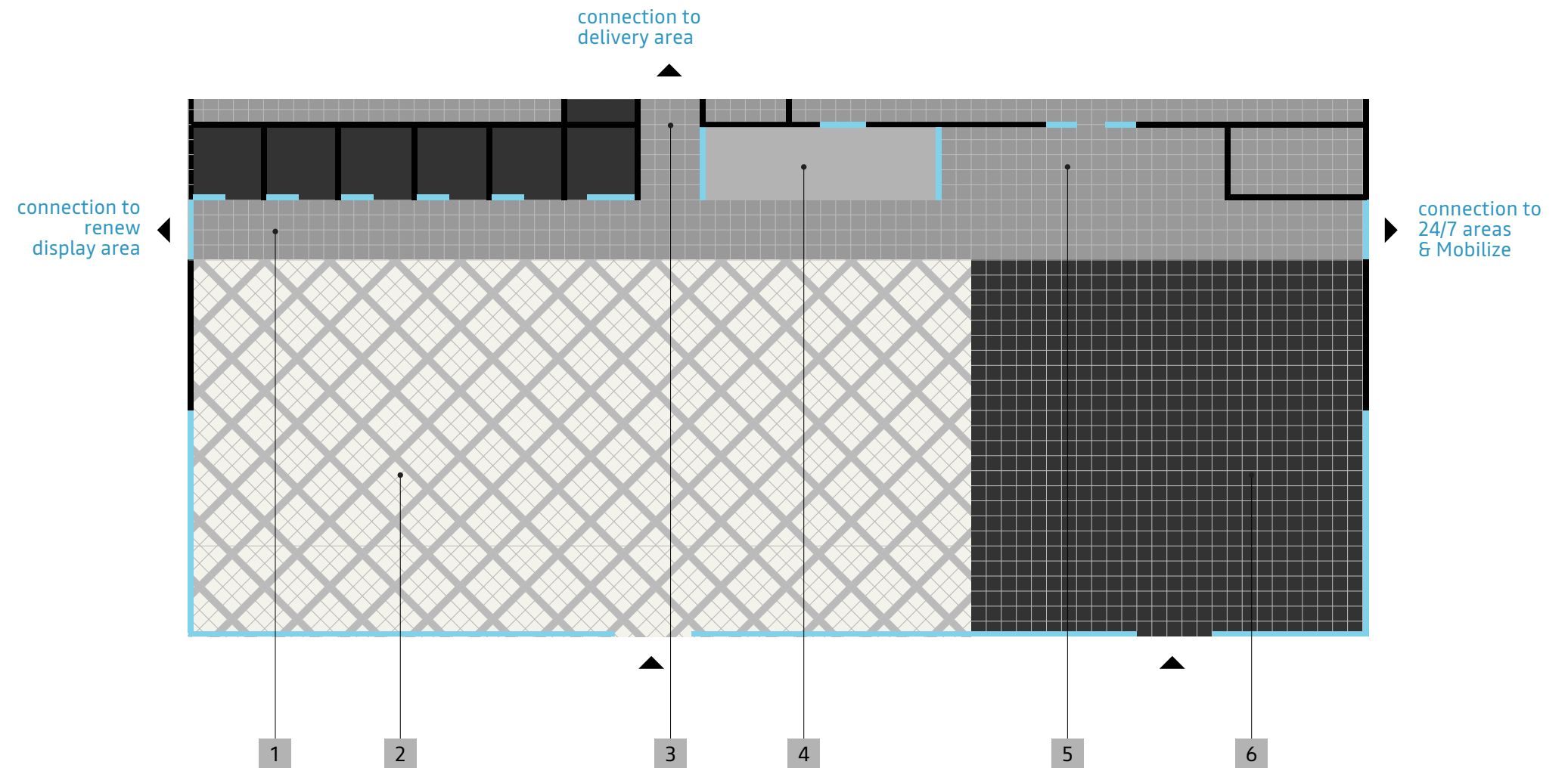

## 5.5.5 Characteristics of the circulation aisle

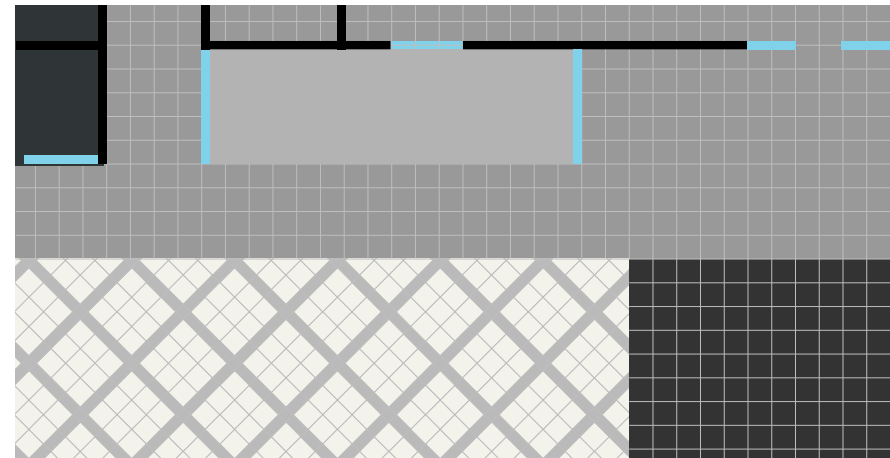

1

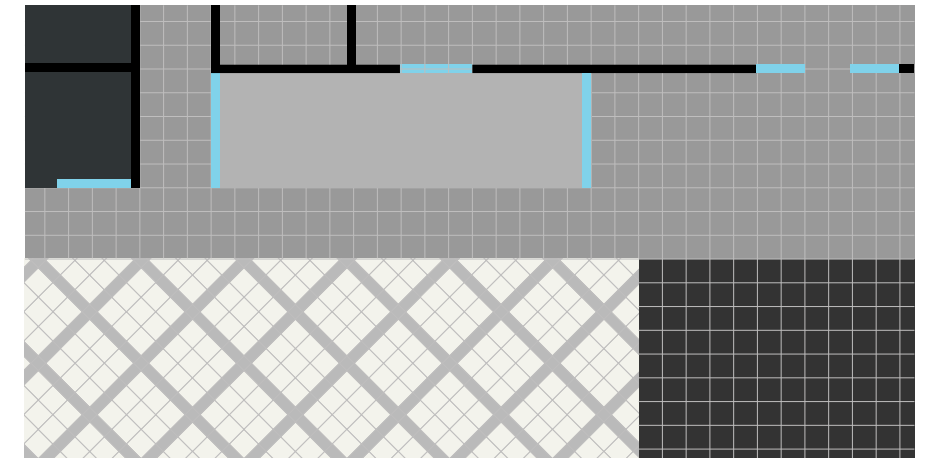

2

### PRINCIPLE

The circulation aisle is fully tiled using a medium grey tile measuring 60 x 60 cm. The recommended width of the circulation path is 1.80 m, corresponding to 3 tiles.

Its width must never be less than 1.40 m corresponding to the 2 passage units of the exit doors to the outside.

Its maximum width will be 3.00 m.

- 1 Circulation aisle of 2.40 m allowing the passage of vehicles in the aisle.
- 2 Standard circulation aisle of 1.80 m.



Novoceram L770-25 Mid-Cool Grey  
600 x 600 mm  
or  
Casagrande RN Seal  
600 x 600 mm  
or  
approved equivalent tiles.



## 5.5.6 Characteristics of the circulation aisle • Don't

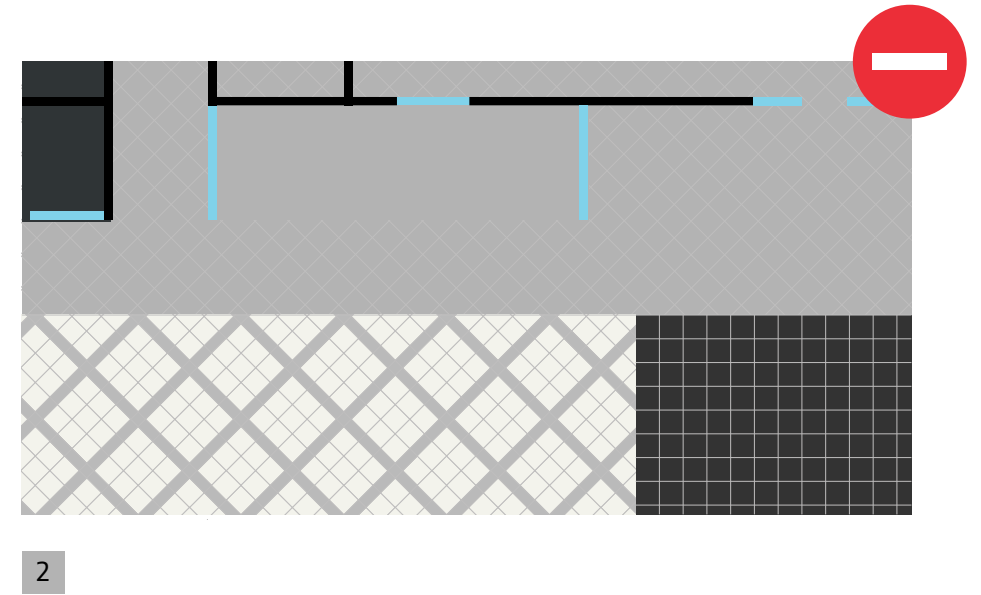
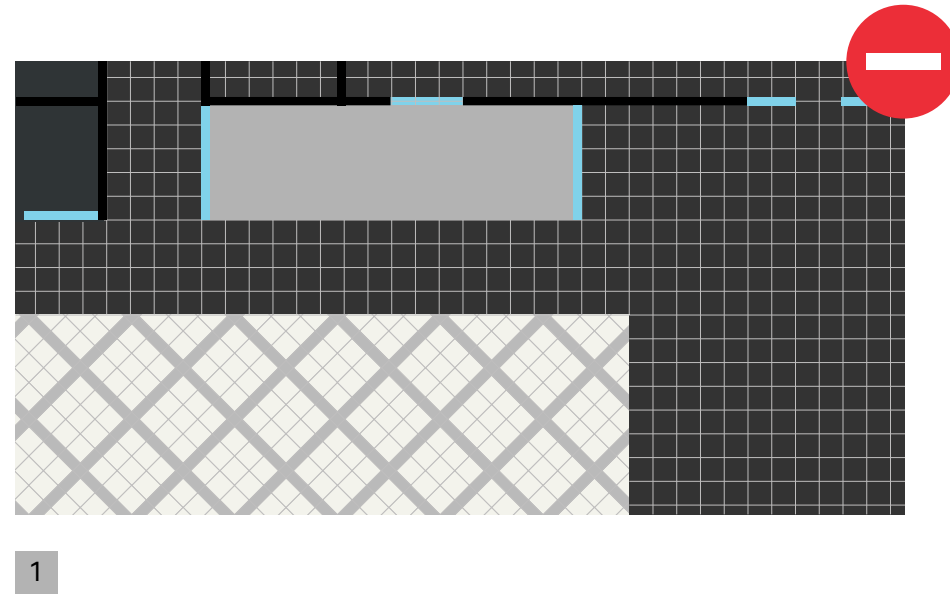

### MAIN PROHIBITIONS

- 1 Tiling of the circulations (and of the common areas) must be different from the tiling of the Dacia showroom.
- 2 Laying of the tiles must be done at 90° to the main façade (same as the Dacia showroom) and not at 45° like the Renault showroom.

## 5.5.7 Implementation examples

### IMPLEMENTATION EXAMPLES

**In the case of showroom facade recesses, the circulation aisle covers the rear part of the showroom in order to preserve the unified vision of the display area spaces.**

A Case where the after-sales facade is set back from the side facade of one of the showrooms.

B Case where the facade of one of the showrooms is not aligned with the second showroom.

- 1 Renault showroom.
- 2 Dacia showroom.
- 3 Circulation aisle.
- 4 Common areas.
- 5 Delivery area.
- 6 After-sales area.
- 7 Back-office workshop.

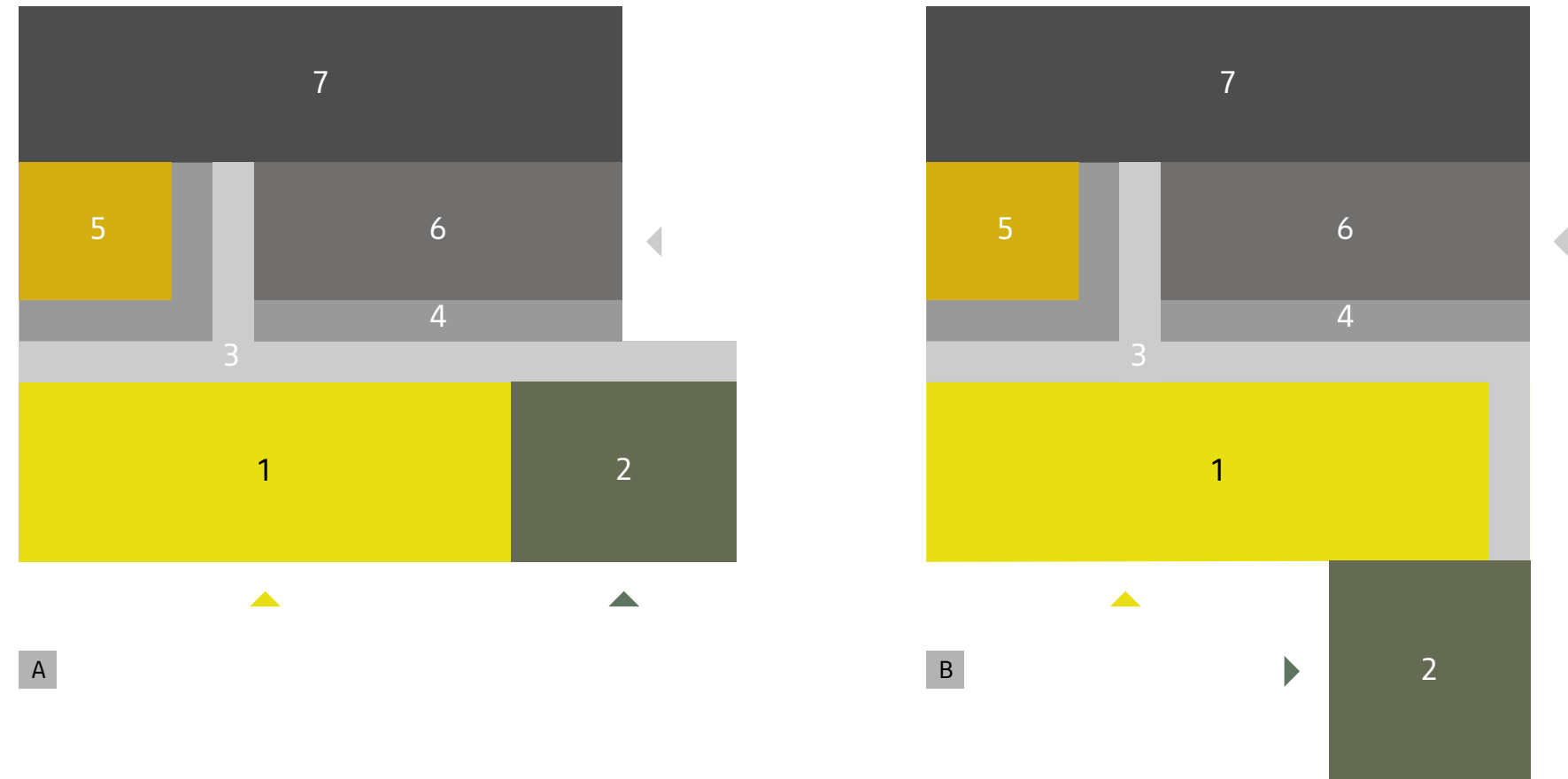

## 5.5.8 Implementation examples • Don't

### MAIN PROHIBITIONS

- A No circulation aisle connecting each of the showrooms to the common areas.
- B Circulation aisle must never cross a showroom, thus cutting it into 2 parts.
- C Circulation aisle must never separate the Renault & Dacia showrooms.

- 1 Renault showroom.
- 2 Dacia showroom.
- 3 Circulation aisle.
- 4 Common areas.
- 5 Delivery area.
- 6 After-sales area.
- 7 Back-office workshop.

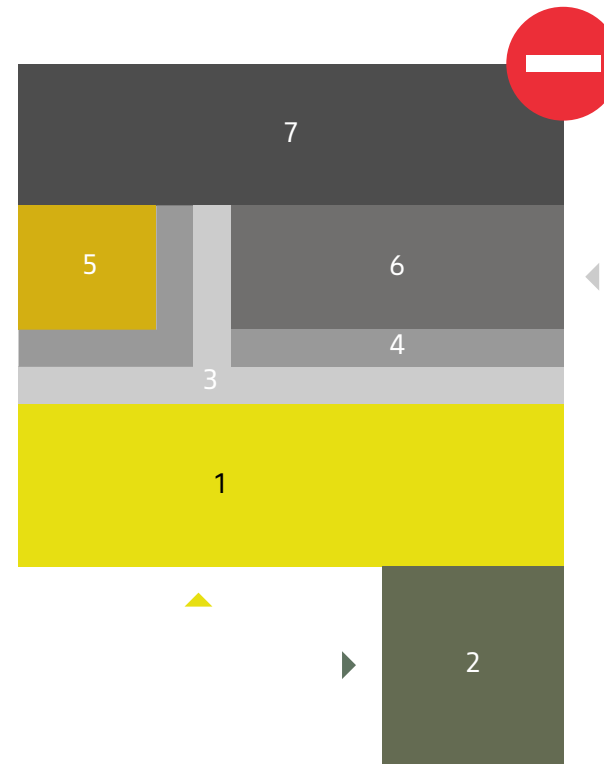

A

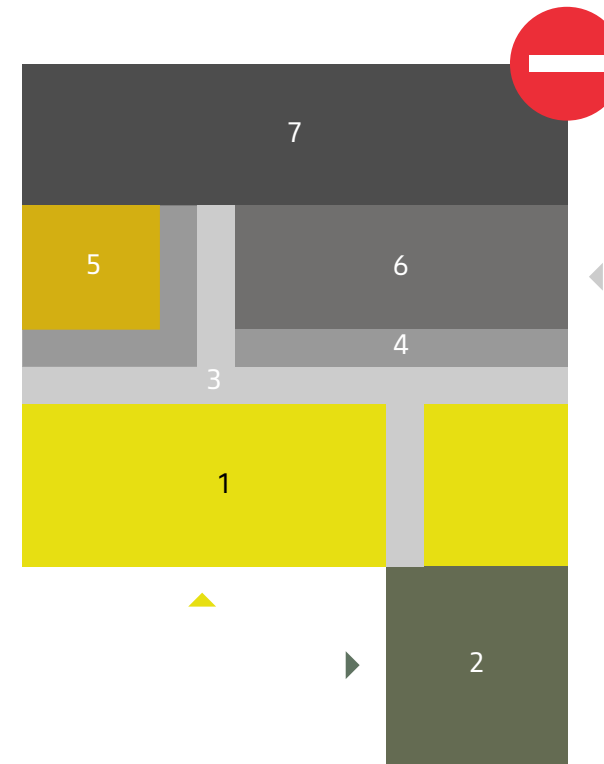

B

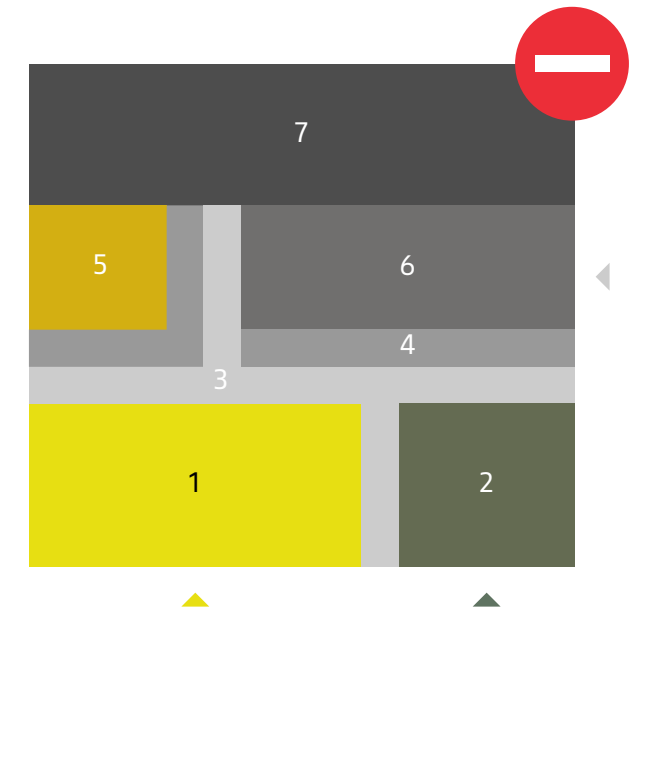

C

6

AFTER-SALES

6.1

AFTER-SALES FACADE SIGNAGE

## 6.1.1 Fundamentals

### **identification principles**

Workshops are shared between Renault and Dacia brands.

The after-sales facades of the multi-brand sites are identified according to methods specific to the multi-brand universe.

In some cases, it may be necessary to use a wall service plate to increase the visibility of the workshops when they are located on a secondary facade and do not offer good visibility from the surroundings.

### **Possible adaptation**

Size and position of the brand plates can be adapted according to the space available on each facade.

### **Don't**

It is forbidden to integrate identities of brands other than Renault and Dacia on the facades.

## 6.1.2 Typical facade

### IDENTIFICATION PRINCIPLES

The bays of the shared workshops of a multi-brand site are identified by plates containing the identifiers of each of the brands.

The group of workshop bays is decorated according to the same principles as for the Renault bays with the exception of:

- texts using the Renault Group Bold typography,
- numbering of the bays which uses the Renault Group Regular typography,
- vertical bands painted in white RAL 9003 instead of yellow.

Brand wall plates are installed next to the panel with the word Workshop.

The Renault plate is always the closest to the workshop bay.

- 1 Dacia wall plate.
- 2 Renault wall plate.
- 3 Wording "Workshop" identifying the group of bays, Renault Group Bold typography,
- 4 Numbering of the workshop bays, Renault Group Regular typography,
- 5 Vertical strip, RAL 9003 white with 40% gloss.

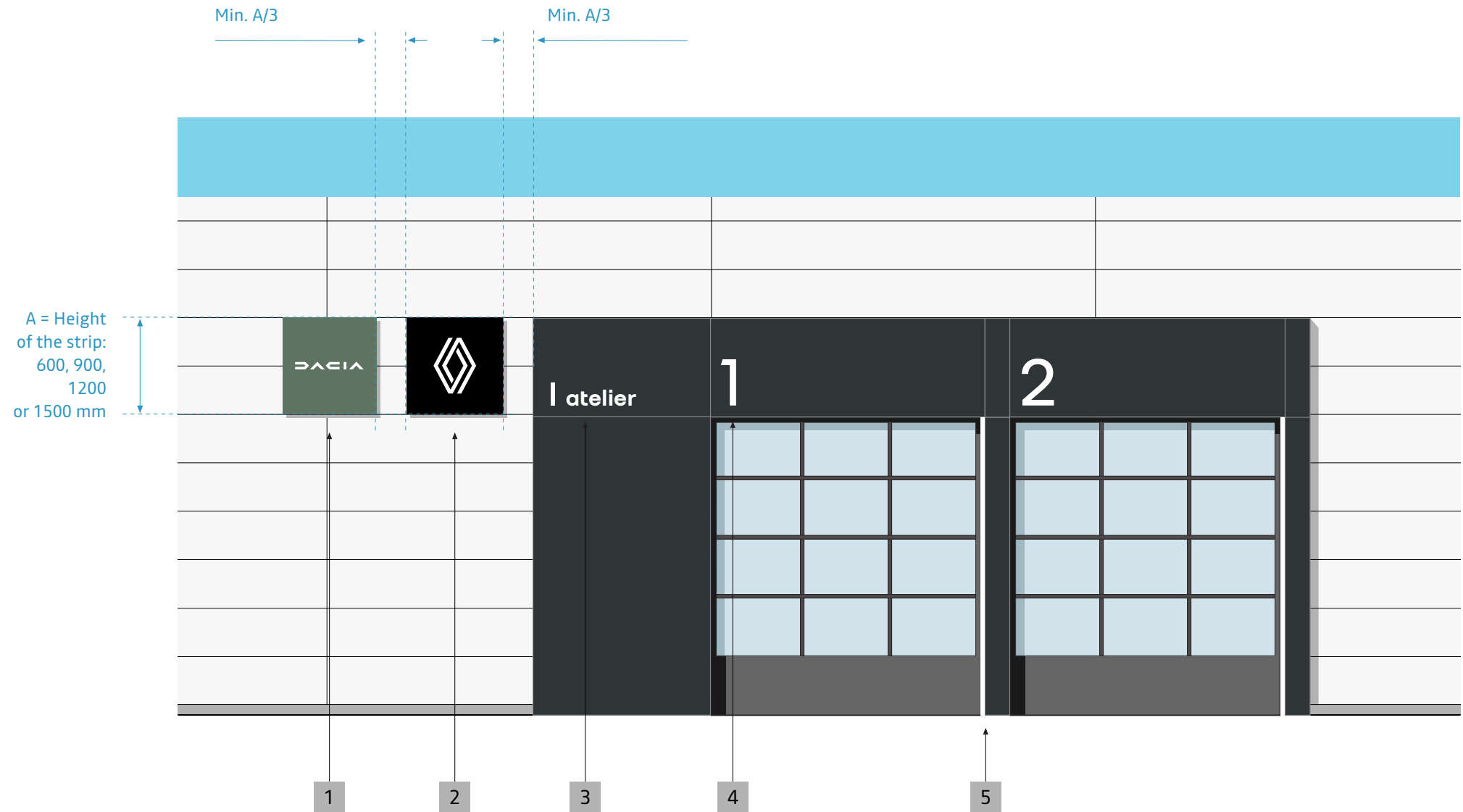

### 6.1.3 Reverse configuration

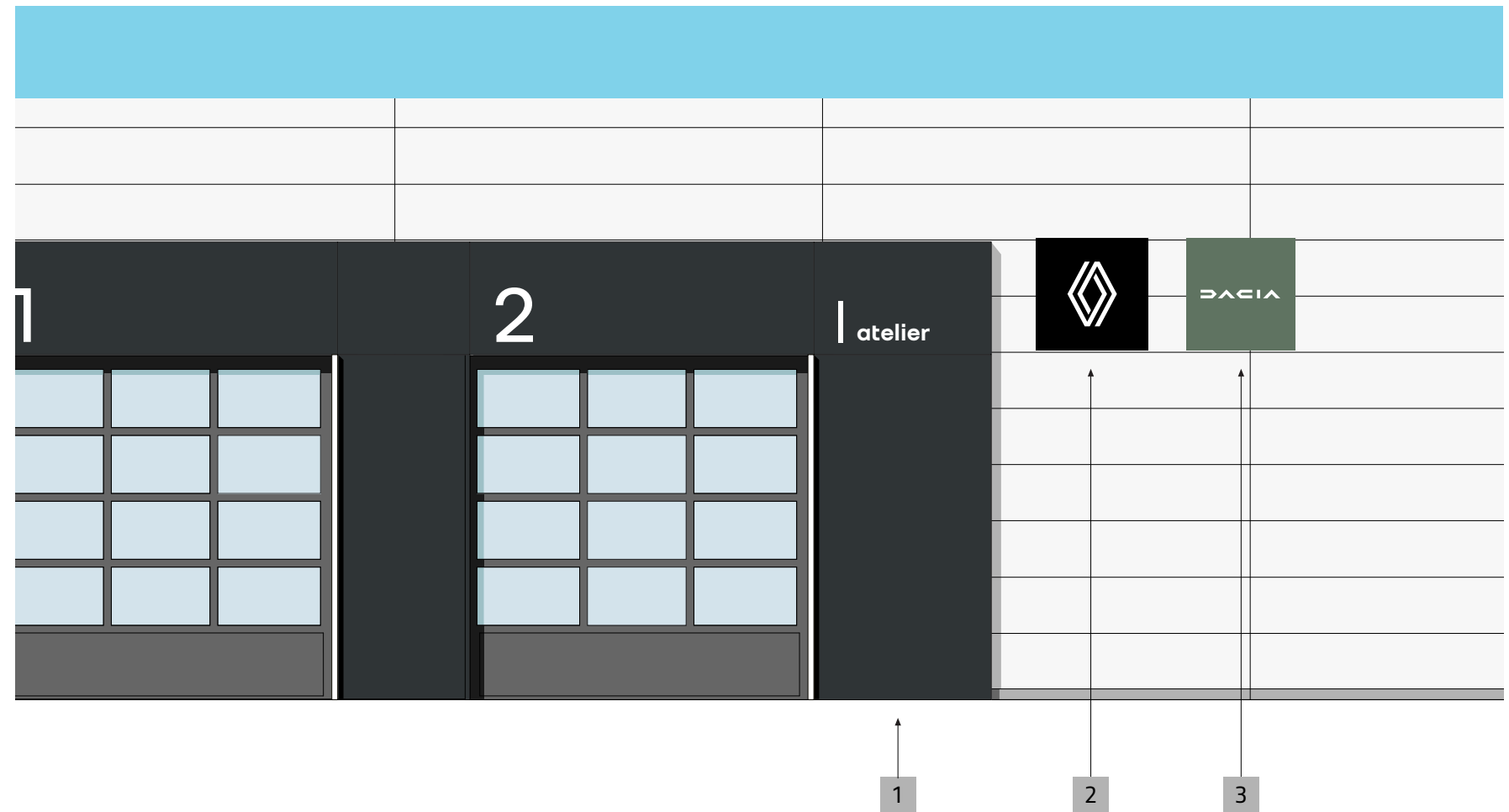

#### IDENTIFICATION PRINCIPLES

In this configuration, reversed compared to the previous page, the Renault wall plate is always installed as close as possible to the workshop bay.

- 1 Workshop bay.
- 2 Renault wall plate.
- 3 Dacia wall plate.



## 6.1.4 Adaptation to the length of facade

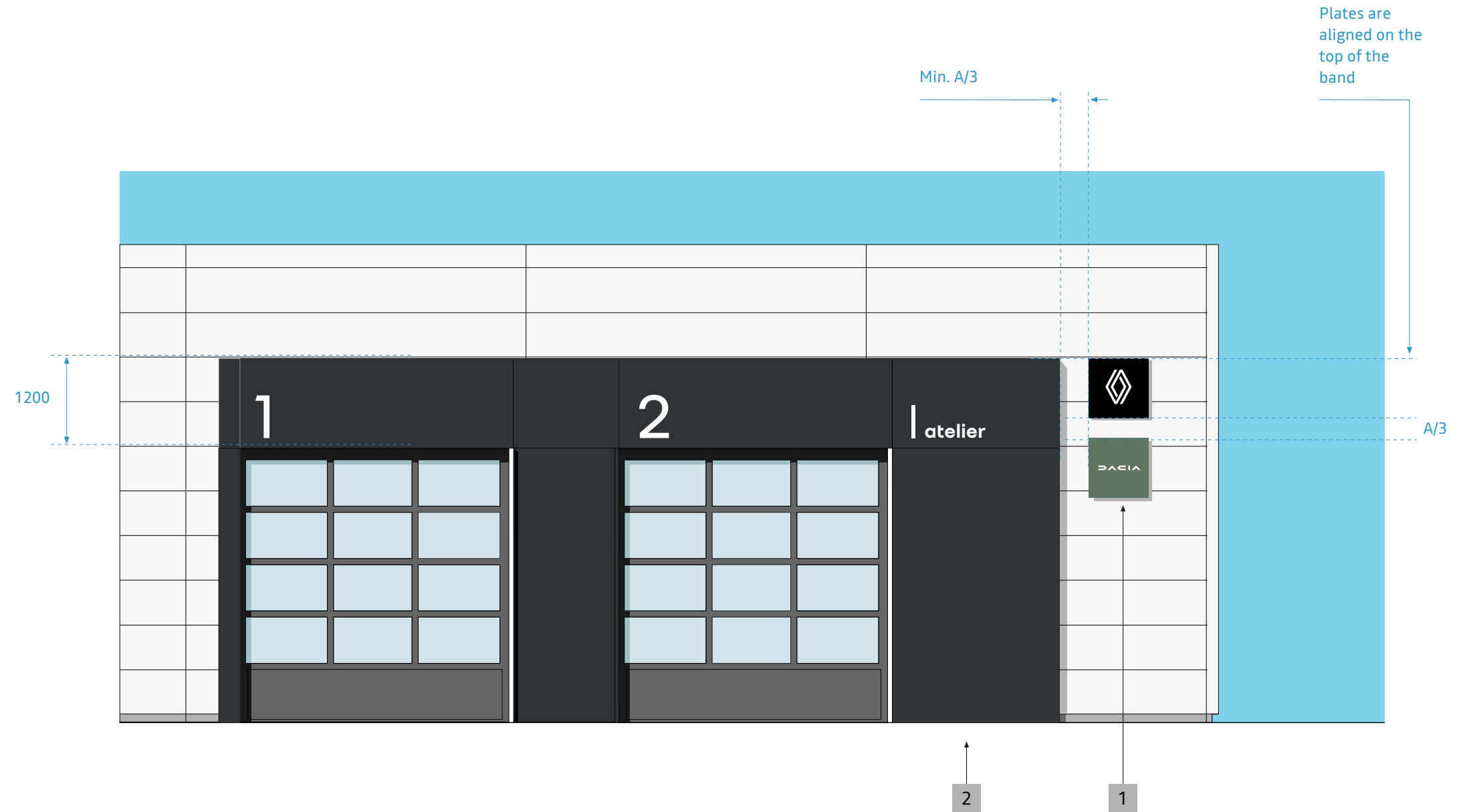

### PRINCIPLES D'ADAPTATION

**When the space available to install the wall plates of the 2 brands is too small, it is possible to use a vertical layout and reduced plate formats.**

Otherwise, the panels have a format of 600 x 600 mm while the workshop bay strip is 1200 mm high.

An installation distance equal to "A/3" from the workshop bay strip must be respected, "A" being the height of the wall plates.

Note that the Renault plate is always positioned at the top, aligned with the top of the workshop bay panel.

1 Wall plates.

## 6.1.5 Low visibility of after-sales facade

### IDENTIFICATION PRINCIPLES

In the event of poor visibility of the after-sales façade from the main access points to the site, it is possible to reinforce the presence of the after-sales activity by installing wall plaques associating the identities of the brands with the mention Service.

This installation must correspond to the need for proximity identification when the customer is invited to go there.

The plaques of the different brands are installed at a minimum distance of "A/3" from each other, "A" being the height of the plaques.

They are aligned from the top and positioned at a minimum distance of 600 mm from the top of the pediment.

The first plaque is installed at a minimum distance of 2 m from the corner of the façade. The Renault plaque is always the closest to the workshop bay.

Standard dimensions: 1350 x 1750 mm.

1. Main façade.
2. Brand wall plaques.
3. Common workshop bays.

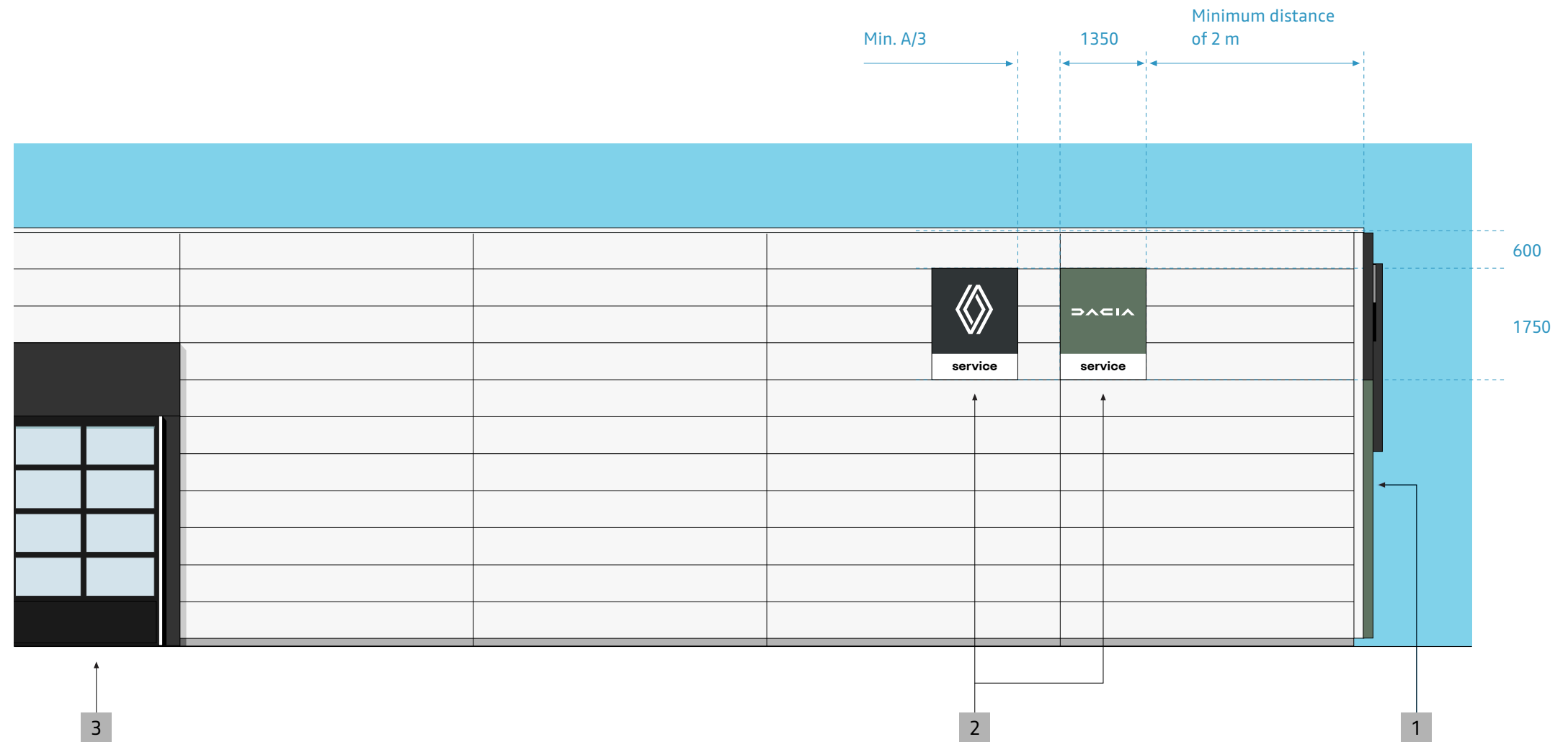

6.2

AFTER-SALES AREA

## 6.2.1 Fundamentals

### **Generic principles**

After-sales area welcomes after-sales customers of all brands with appointments on board their vehicle.

They are invited to park their vehicle in the Tour du vehicule area where they are greeted by a service advisor.

After-sales area is connected to the service reception, where the repair order is issued and the work carried out is billed.

The waiting lounge is located next to the service reception.

The care service minute workstations integrated into the after-sales area respond to common rapid interventions.

### **Possible adaptation**

The surface of this after-sales area (and the number of places) is adapted to the number of workshop entries per day of each site.

### **Don't**

Alpine customers are always welcomed in the brand's showroom and do not have to come to the after-sales area.

## 6.2.2 General layout

### IMPLEMENTATION PRINCIPLES

The after-sales area is part of the front office.

Nearly 80% of interventions are carried out in less than 1 hour by appointment thanks to the mobilization of 2 companions around the vehicle.

- 1 Showrooms are open to the service reception.
- 2 Circulation aisle ensures the connection between the 2 areas and the separation between the common services and the showrooms.
- 3 Service reception is located near the after-sales area from which it is separated by a glass wall.
- 4 Waiting lounge is adjacent to the service reception. It is separated from it by a glass partition.
- 5 After-sales area has a lifting entrance door allowing customers to access it in their vehicle.
- 6 A lifting door connects the after-sales area to the back-office workshop.
- 7 The handback parking lot is located near the after-sales area.
- 8 A mobility offer is available near the after-sales area. It allows customers to have a replacement vehicle as part of after-sales operations immobilizing the vehicle.



## 6.2.3 Tour of vehicle perpendicular layout

### GENERIC PRINCIPLE

As part of maintenance and repair operations, all after-sales customers (all brands) with an appointment must arrive in their vehicle in the after-sales area to park in the tour of vehicle area.

- 1 Tour of vehicle area is identified by a marking on the ground with the word Welcome.
- 2 The different slots are marked on the ground with white markings.
- 3 Protected paths ensure the safety of customers and Renault personnel. They connect this area to the service reception.

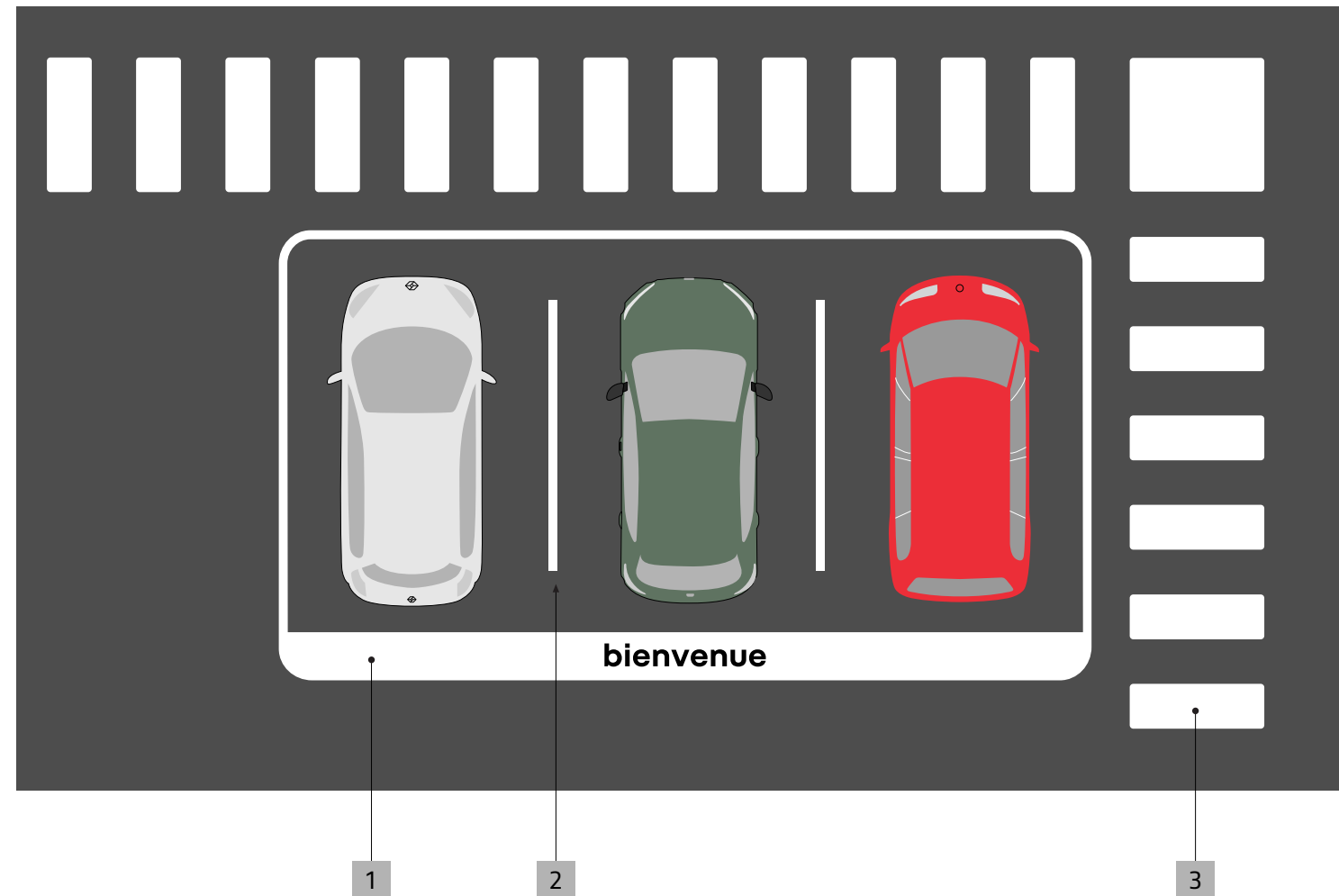

## 6.2.4 Tour of vehicle diagonal layout

### GENERIC PRINCIPLE

When the Tour of vehicle area is arranged against a wall, the vehicles are parked at a 45° angle to facilitate maneuvers.

- 1 Principle of marking the zone is identical to that of vehicles parked at an angle.
- 2 Space separation lines are inclined at 45°.
- 3 Pedestrian path is offset by 200 mm from the Tour of vehicle area marking.
- 4 Tour of vehicle area is offset by 400 mm from the showroom wall.

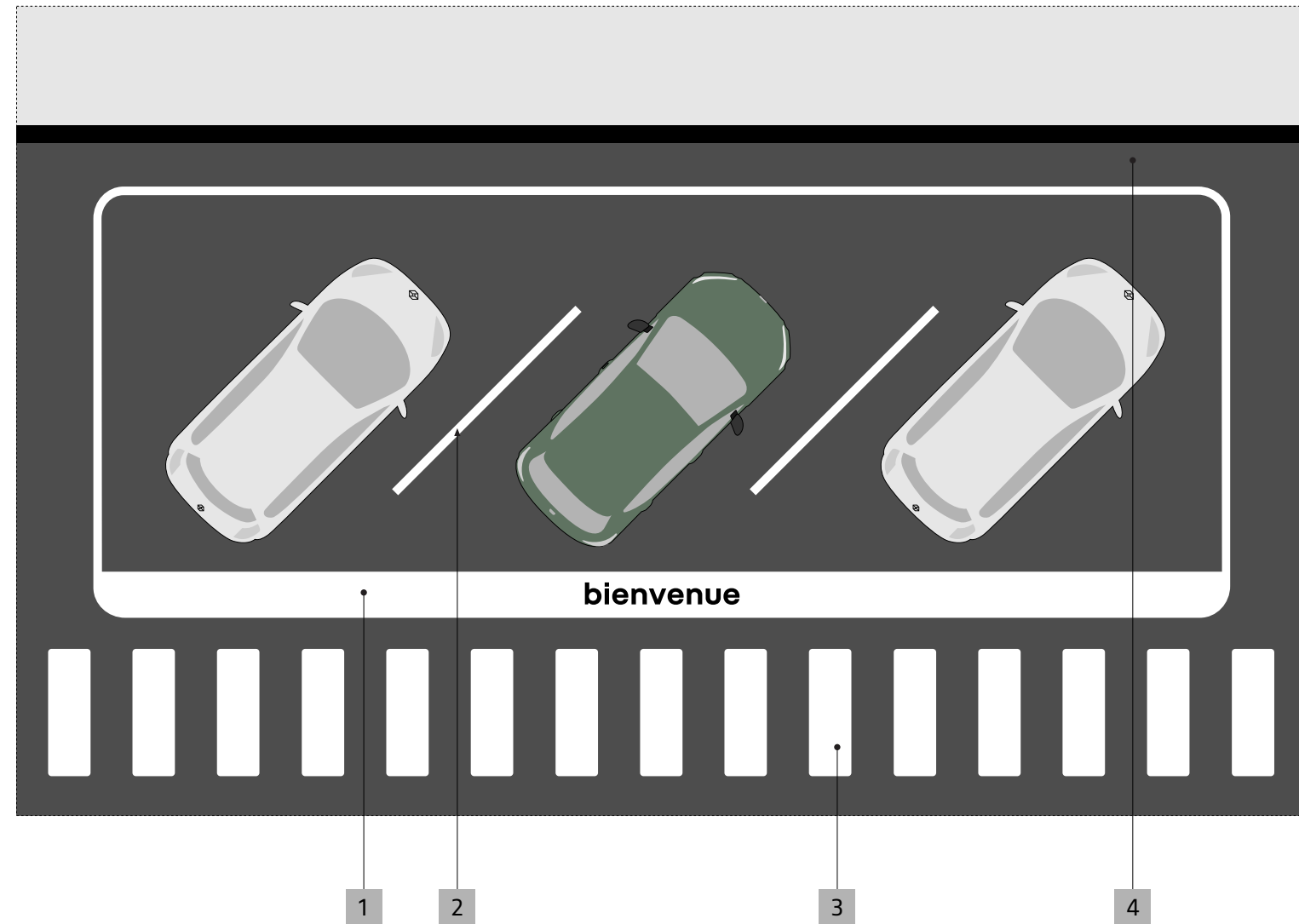

## 6.2.5 Waiting car park

### GENERIC PRINCIPLE

**After signing the repair order at the reception service, the Service advisor moves the vehicle to the workshop or near the care service minute stations depending on the type of intervention to be carried out.**

The parking spaces benefit from simple markings aimed at showing the organization of the after-sales area.

- 1 The parking spaces are marked with white strips. The surface reserved per vehicle is 3000 x 5000 mm.
- 2 When the pedestrian path is arranged in front of the parking spaces, it is located 200 mm from the parking space markings.
- 3 When it is located against a wall, the return parking is offset by 400 mm from the showroom wall.

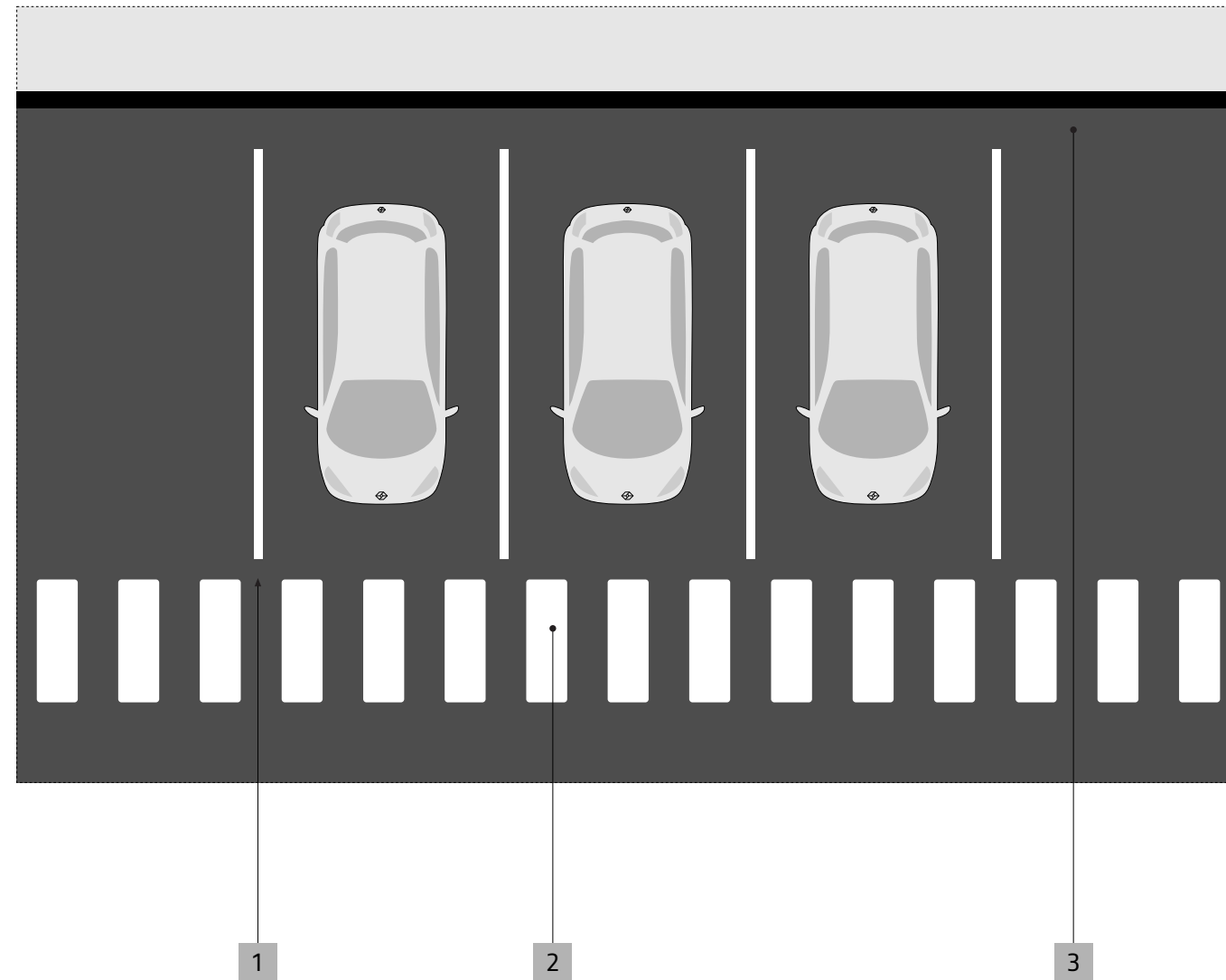



## 6.2.6 Care service minute stations

### GENERIC PRINCIPLE

**The care service minute stations allow for rapid intervention on vehicles within the after-sales area.**

Possibly, one of the stations can be used by a cotech to carry out a diagnosis following the Tour of vehicle.

- 1 Limits of the work stations are marked by white strips.
- 2 Surface area reserved for each station is 4 x 6 m, allowing easy movement around each vehicle.
- 3 An additional space with a minimum width of 2.5 m is located behind the stations, providing operators with various tools such as tire machines, balancers, etc. as well as the most common spare parts.

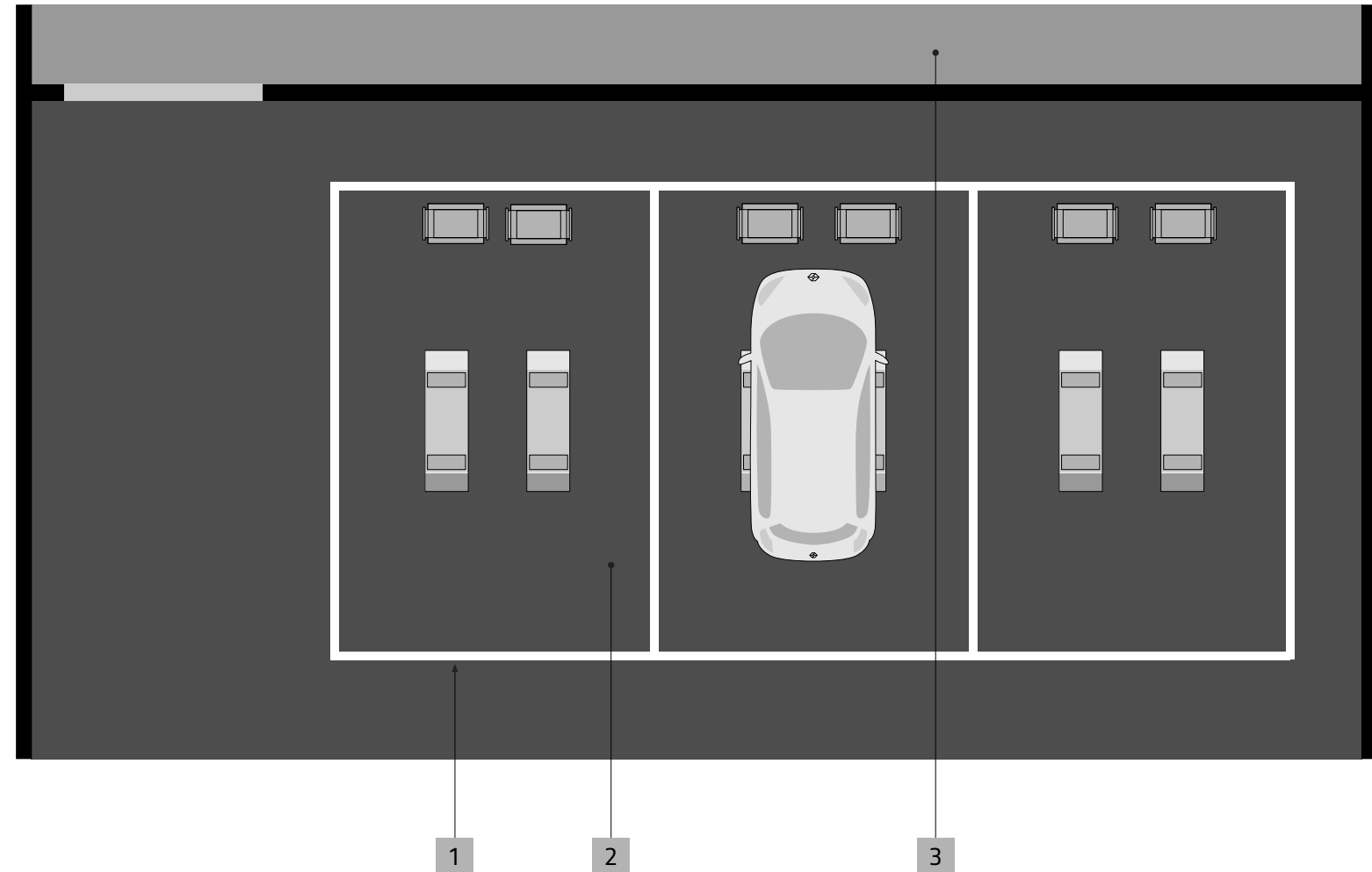

## 6.2.7 The handback car park

### GENERIC PRINCIPLE

After-sales service is complete, the vehicles are parked in the handback car park located in front of the after-sales facade, near the service reception.

- 1 The strips on the ground are placed 200 mm from the edges of the central reservations.
- 2 The parking spaces are marked with white strips. Surface area reserved per vehicle is 3000 x 5000 mm.
- 3 The pedestrian path is placed in front of the parking spaces, it is placed 200 mm from the parking space markings.
- 4 Vehicles are parked with the front facing the exit of the car park.

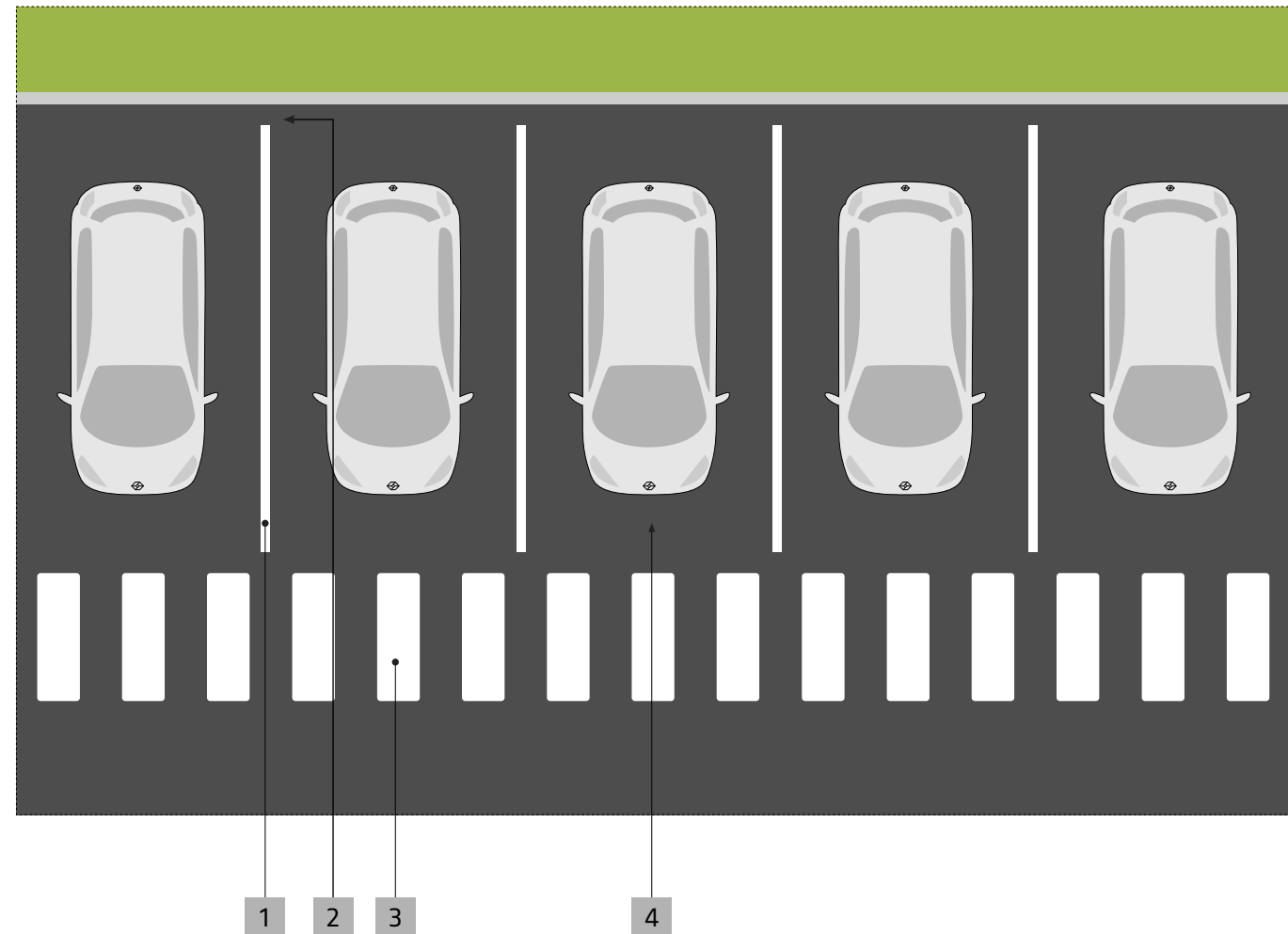

7

24/7 CUSTOMER SERVICES

7.1.

CARE SERVICE 24/7 ZONE

## 7.1.1 Fundamentals

### **Generic rule**

The implementation of the care service 24/7 zone responds to a change in the needs of customers who wish to have a service outside the opening hours of the sites, allowing them to drop off and pick up their vehicle as part of after-sales operations.

Care service 24/7 zone is located near the service reception to which it is connected by a pedestrian path.

### **Possible adaptation**

Sizing of the care service 24/7 zone will be adapted to the evolution of the fleet of electrified vehicles, the type of work to be carried out on the site and the location of the site in relation to potential customers.

## 7.1.2 Signage elements

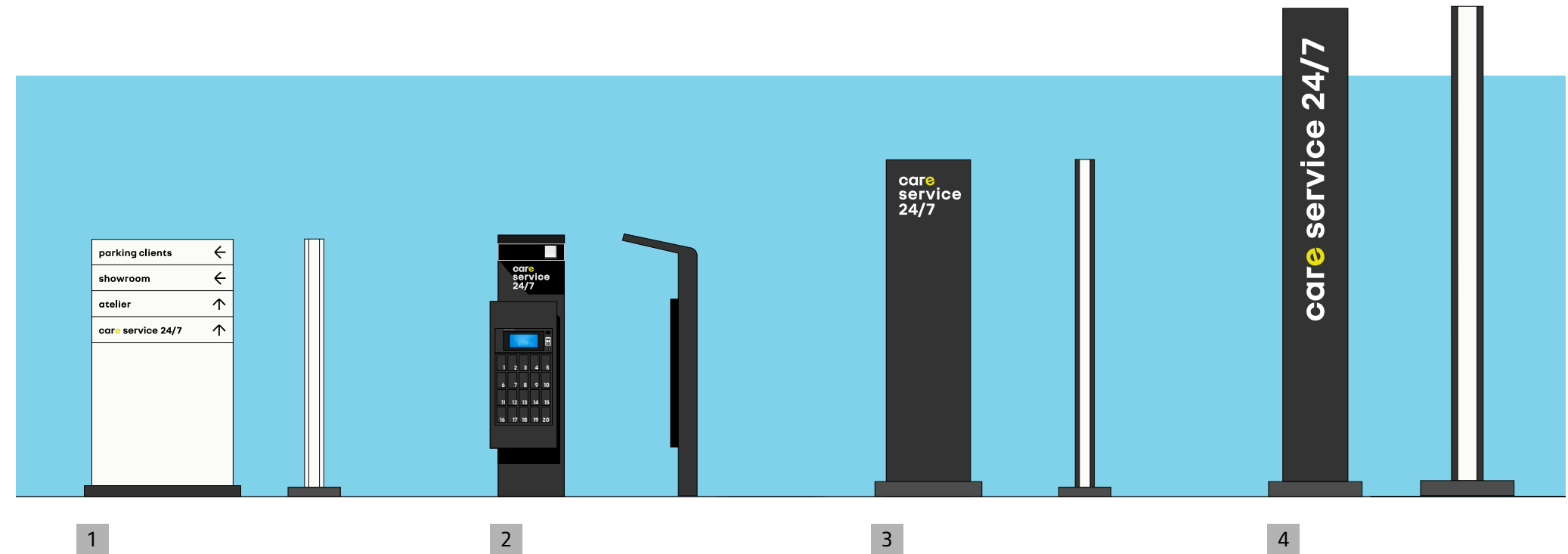

### IDENTIFICATION PRINCIPLES

The identification of the care service 24/7 zone is based on the use of signage supports allowing it to integrate harmoniously into the surroundings of multi-brand sites while offering it high visibility.

- 1 Directional sign.
- 2 Key box (a wall-mounted version is also available).
- 3 Identification sign.
- 4 Area mast.

## 7.1.3 General layout

### IMPLEMENTATION PRINCIPLES

Care service 24/7 zone is presented in the form of a parking area accessible outside the opening hours of the site allowing the drop-off and pick-up of vehicles by customers.

The operation of the zone is based around a key box which ensures the transfer of keys and administrative documents related to the intervention.

This key box is located in an area allowing good accessibility to customers including PRMs in complete safety.

When a PRM space is present in the care service 24/7 zone, it is positioned as close as possible to the key box.

- 1 Pedestrian path.
- 2 Key box.
- 3 White demarcation strips.
- 4 Protection posts.
- 5 Directional sign.
- 6 Area mast.
- 7 Zone identification strip on ground.

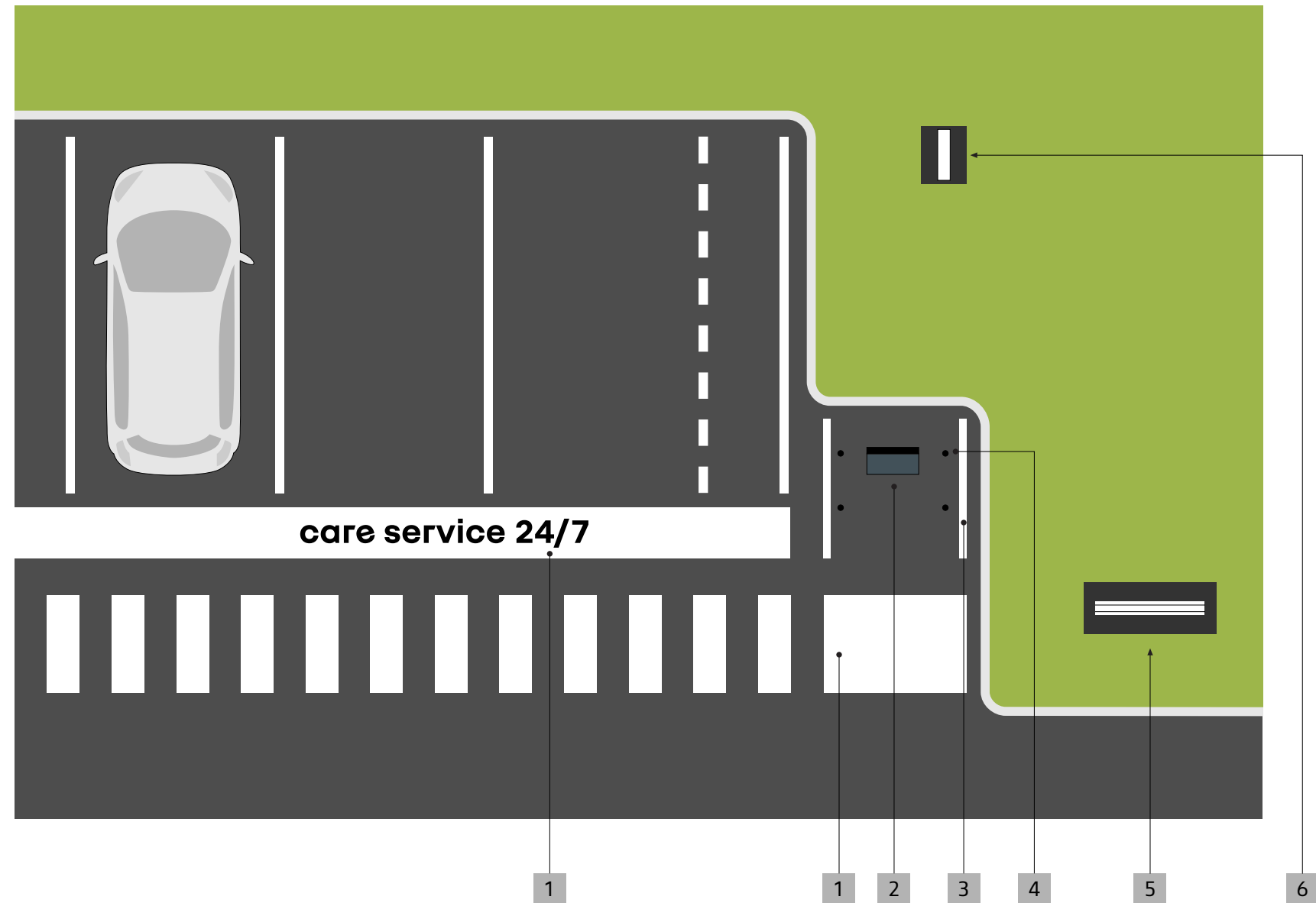

## 7.1.4 Basic configuration with 2 parking spaces

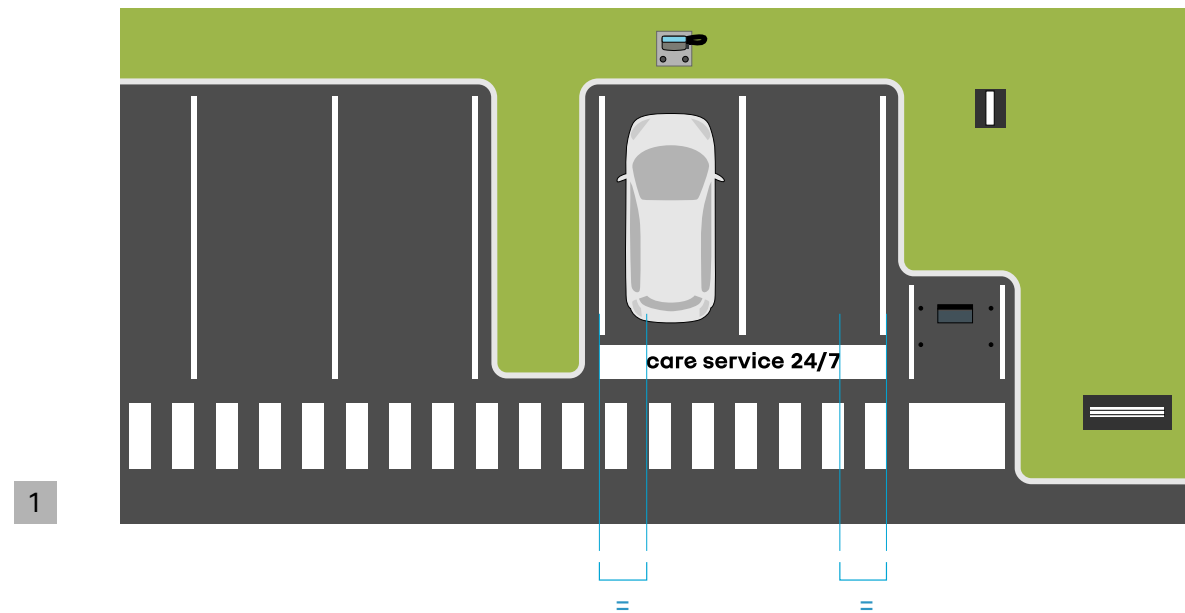

1

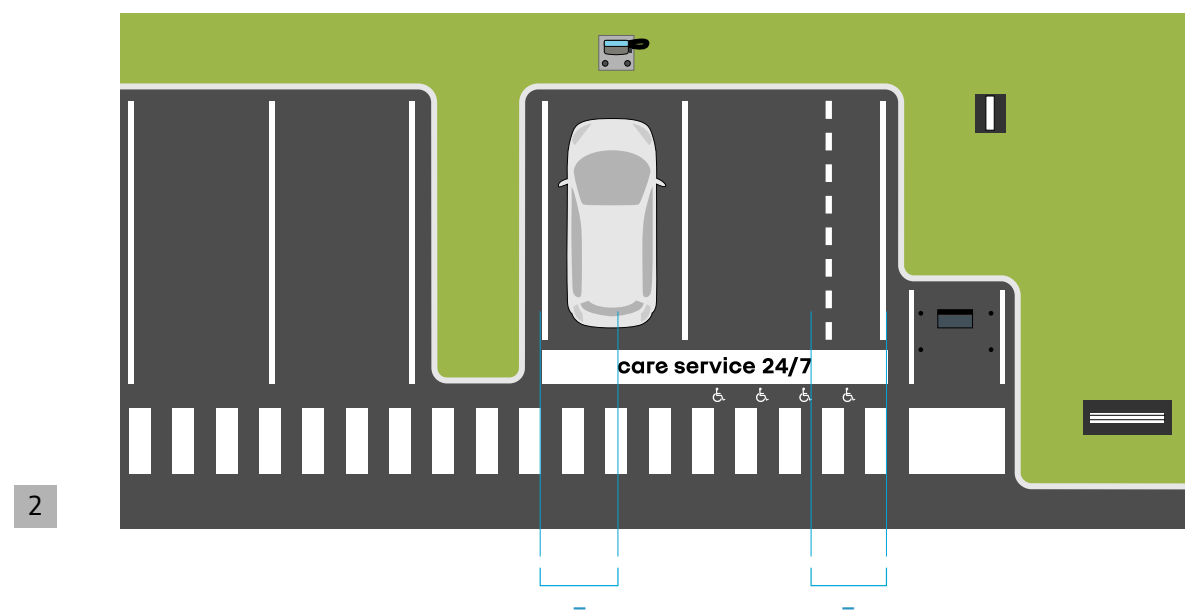

2

### GENERIC PRINCIPLE

Care service 24/7 zone has at least 2 places.

- 1 Configuration with 2 places.
- 2 Configuration with 2 places including 1 PMR place.



## 7.1.5 Modularity of the area

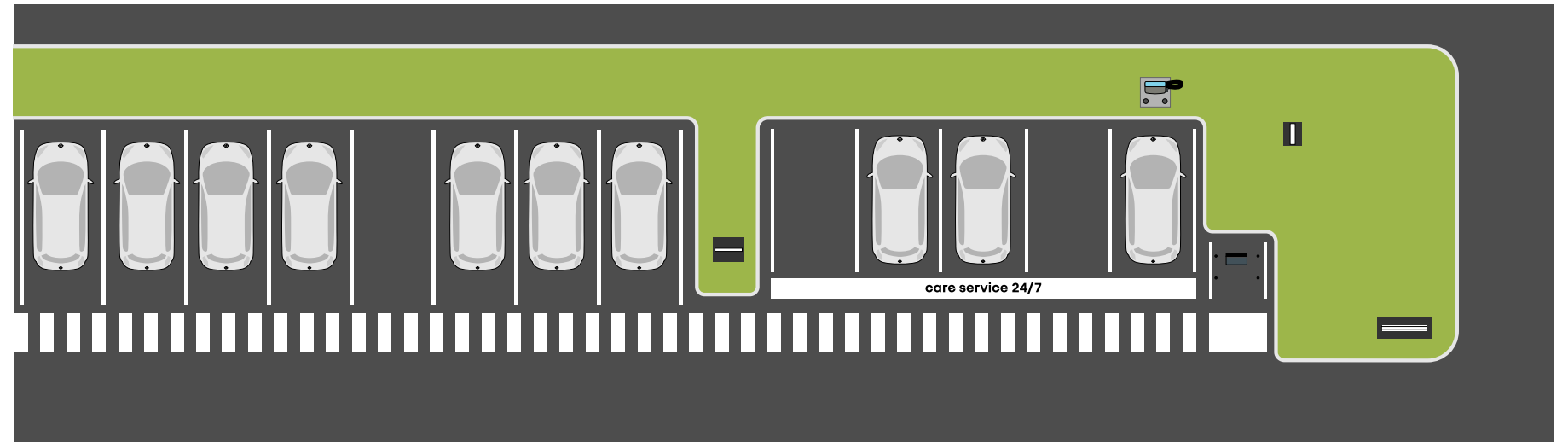

1

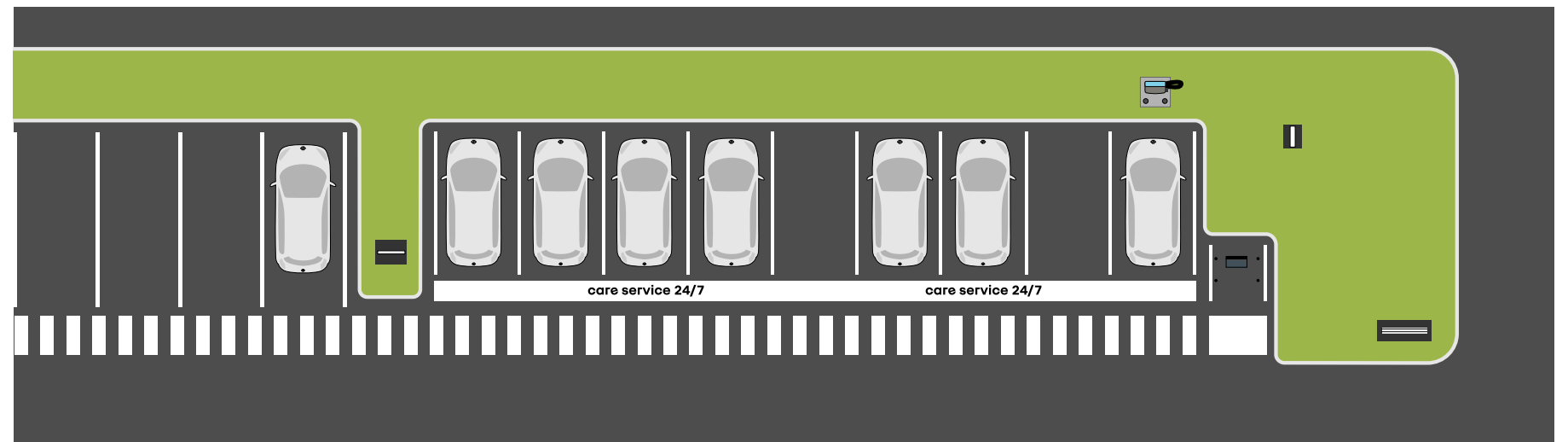

2

### EXTENSION PRINCIPLE

The extension of a care service 24/7 zone is done by adding parking spaces to complete the basic configuration of 2 spaces.

1. Parking zone with less than 9 spaces.
2. Parking with 9 spaces and more.

## 7.1.6 Parking spaces

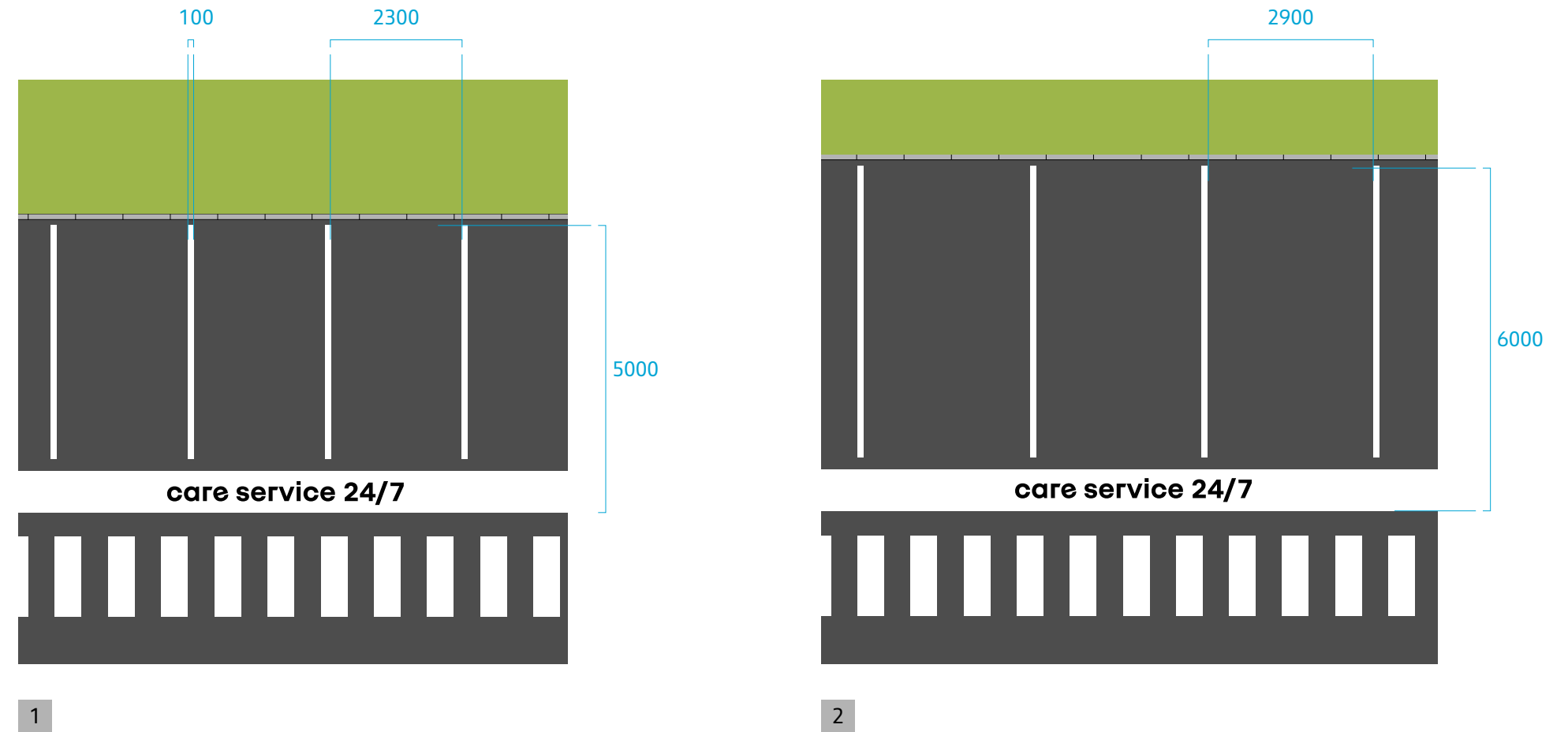

### ADAPTATION PRINCIPLE

Spaces intended for utility vehicles are mandatory within the framework of the sites offering a Renault Pro+ activity.

Parking spaces dedicated to LCVs use the same identification rules as the standard spaces.

Their dimensions are enlarged in order to accommodate larger vehicles.

1 Standard spaces in the 2300 x 5000 mm format.

2 LCV spaces in the 2900 x 6000 mm format.

## 7.1.7 Juxtaposition principle

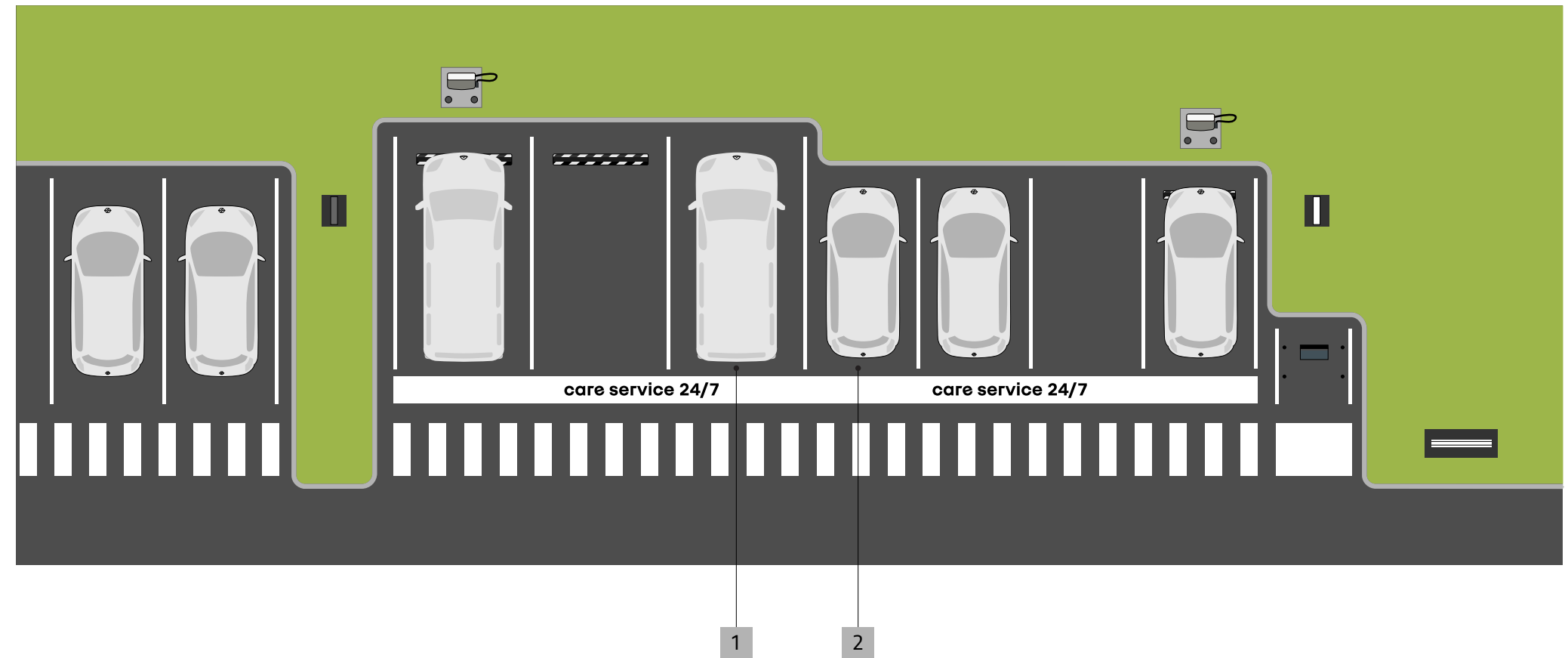

### LAYOUT PRINCIPLE

**The spaces intended for utility vehicles are grouped together and preferably located opposite the key box.**

Parking spaces dedicated to LCVs are juxtaposed with the standard-sized spaces.

- 1 LCV spaces in the 2900 x 6000 mm format.
- 2 Standard spaces in the 2300 x 5000 mm format.

## 7.1.8 Sizing chart

\* workshop customer entries per day excluding bodywork

	up to 10 entries *	from 10 to 20 entries *	from 20 to 30 entries *	comments
Standard parking spaces	2 (mandatory)	4 (mandatory)	6 (mandatory)	Replacement vehicles are managed by Mobilize Share.
PMR parking space	1 (optional)	1 (optional)	1 (optional)	Mandatory disabled parking space when the disabled parking spaces in the customer car park are not accessible 24/7 or located more than 200 m from the care service 24/7 zone
LCV parking spaces	1 (mandatory)	1 (mandatory)	1 (mandatory)	Parking spaces are oversized to accommodate light commercial vehicles: 2900 x 6000 mm instead of 2300 x 5000 mm
Ground markings	1 (mandatory)	1 (mandatory)	1 (mandatory)	Ground markings of the squares are done with a stencil for the lettering and pictograms and using a machine for the straight strips.
Identification panel	1 (optional)	1 (optional)	1 (optional)	Choice between these 2 elements depending on implementation conditions and regulations.
Aera mast	1 (mandatory)	1 (mandatory)	1 (mandatory)	
Key box	1 (mandatory)	1 (mandatory)	1 (mandatory)	For the French network, this element was selected from the ACSES supplier. It is common to all configurations. A wall-mounted version may be necessary.
Charging station	1 (optional)	1 (optional)	1 (optional)	Optional charging station for recharging electric vehicles when returning them following after-sales operations (non-monetized charging).

mandatory  
 optional

### LAYOUT PRINCIPLE

Capacity of the care service 24/7 zone and the configurations are adapted according to the number of workshop entries/day of each of the sites.

## 7.1.9 Integration into the general drawing

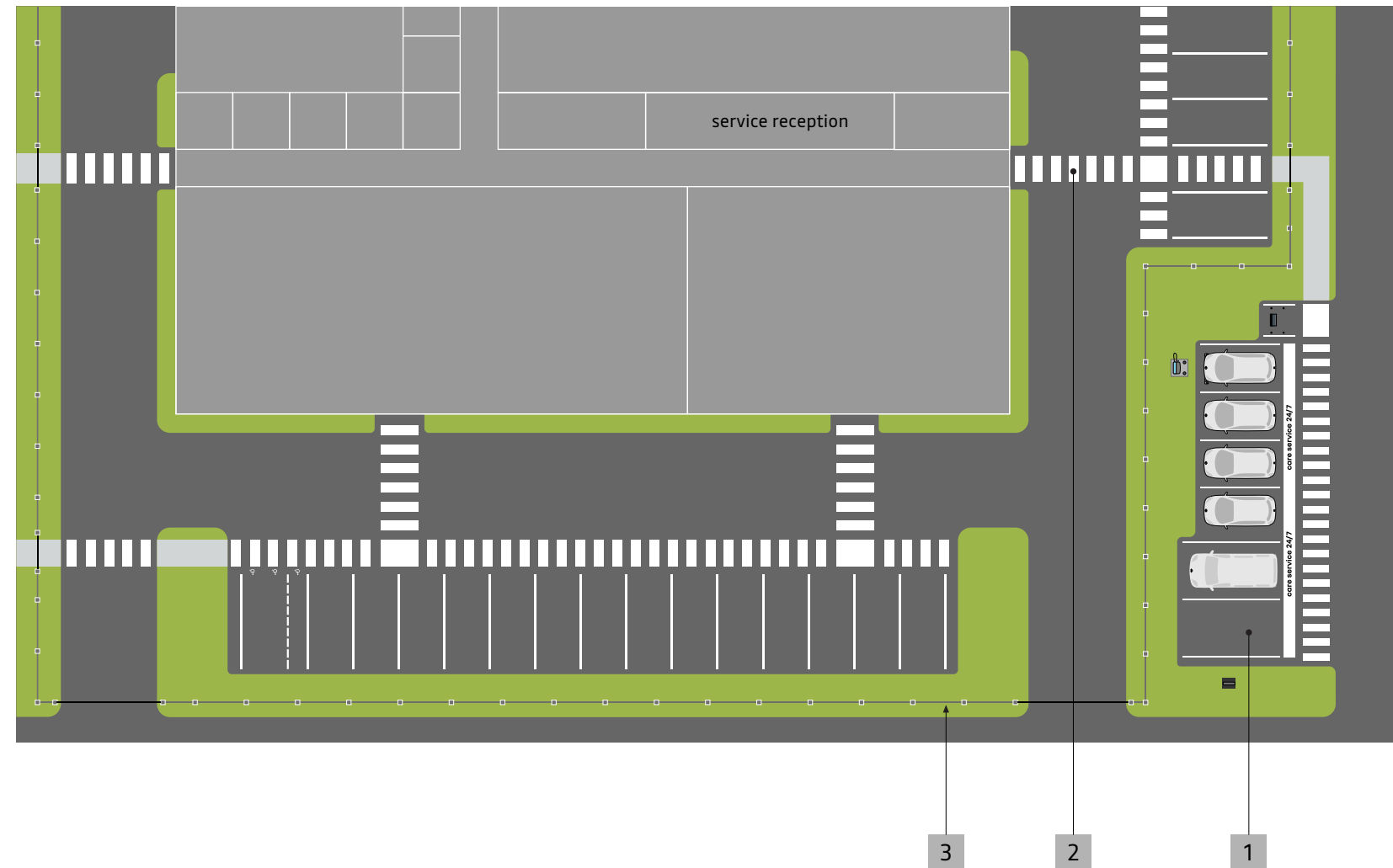

### IMPLEMENTATION PRINCIPLES

**Due to its function, the care service area is linked to the main after-sales areas: care service reception, return parking, after-sales area.**

- 1 Care service 24/7 zone is located outside the protected perimeter of the site to allow access at any time of the day.
- 2 The circulation aisle and its extension by a protected passage provide the link between the service reception and the care service 24/7 zone.
- 3 Protected perimeter of the site.

7.2

MOBILIZE SHARE ZONE

## 7.2.1 Fundamentals

### **Generic principle**

The implementation of the Mobilize share zone meets the needs of customers to have a replacement vehicle in the event of immobilization of their vehicle as part of after-sales operations.

Mobilize Share customers, via the application dedicated to vehicle rental, can also directly access a vehicle via their smartphone.

To gain efficiency, it is recommended to create a common area grouping the Mobilize share and care service 24/7 services.

### **Possible adaptation**

This area must be accessible at all times of the day.

Depending on the location of the site in relation to potential customers, charging stations must be integrated into this area to allow rental vehicles to be charged autonomously.

## 7.2.2 Signage items

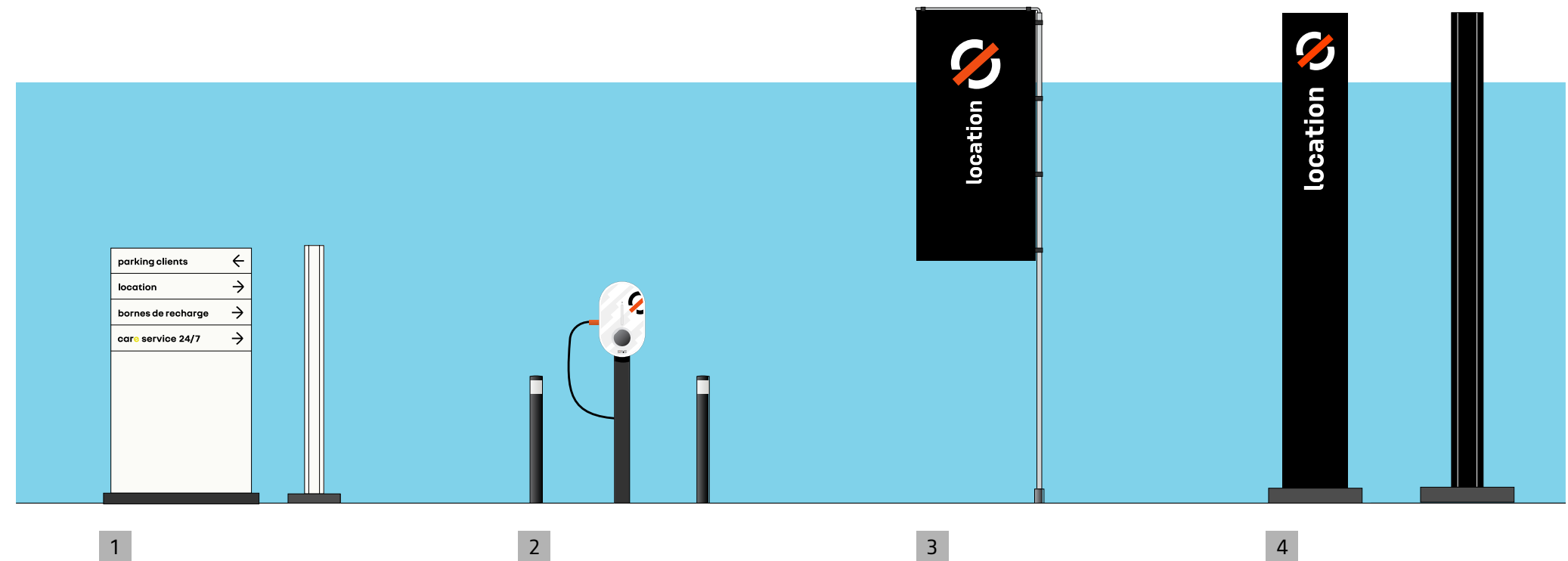

### IDENTIFICATION PRINCIPLES

Identification of the Mobilize share zone is based on the use of signage supports allowing it to integrate harmoniously into the surroundings of multi-brand sites while offering it high visibility.

- 1 Directional sign.
- 2 Charging station.
- 3 Identification banner (option).
- 4 Aera mast.



### 7.2.3 Example of a configuration for up to 10 workshop entries per day

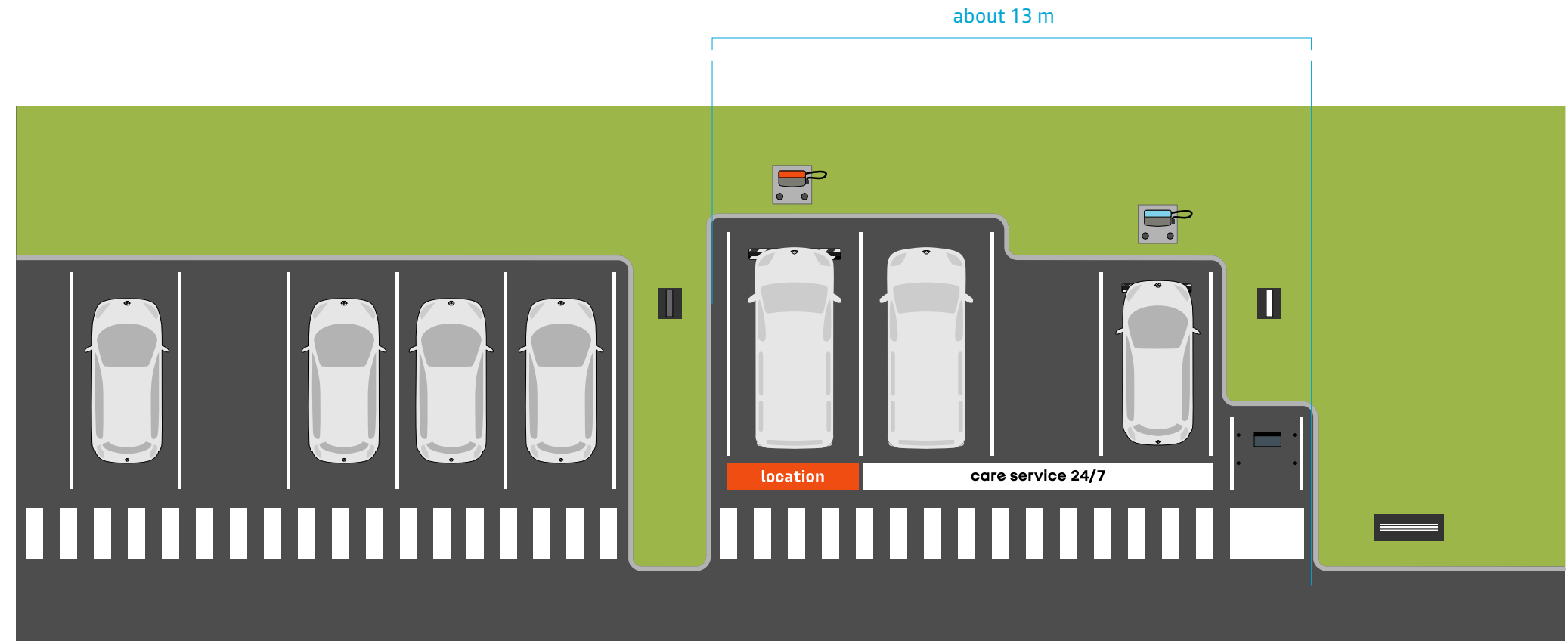

#### DESCRIPTION

**In this configuration, the care service 24/7 & Mobilize share areas occupy an area of around 104 m<sup>2</sup> (excluding traffic).**

This configuration does not include a PMR space because it is accessible in the customer parking lot of the site.

The 2 areas are juxtaposed in order to reduce the occupied surface area.

## 7.2.4 Example of a configuration of 10 to 20 workshop entries per day

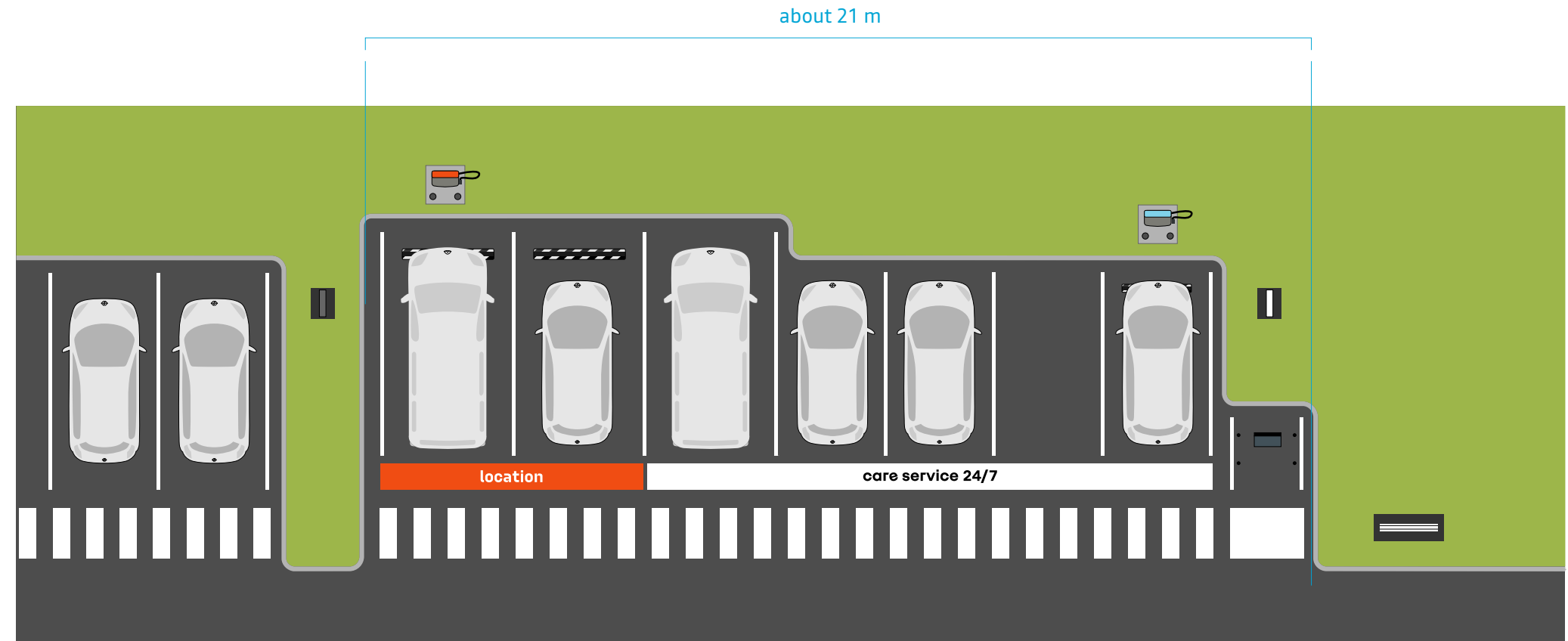

### DESCRIPTION

**In this configuration, the care service 24/7 & Mobilize share areas occupy an area of around 168 m<sup>2</sup> (excluding traffic).**

This configuration does not include a PMR space because it is accessible in the customer parking lot of the site.

The 2 areas are juxtaposed in order to reduce the occupied surface area.

## 7.2.5 Example of a configuration of 20 to 30 workshop entries per day

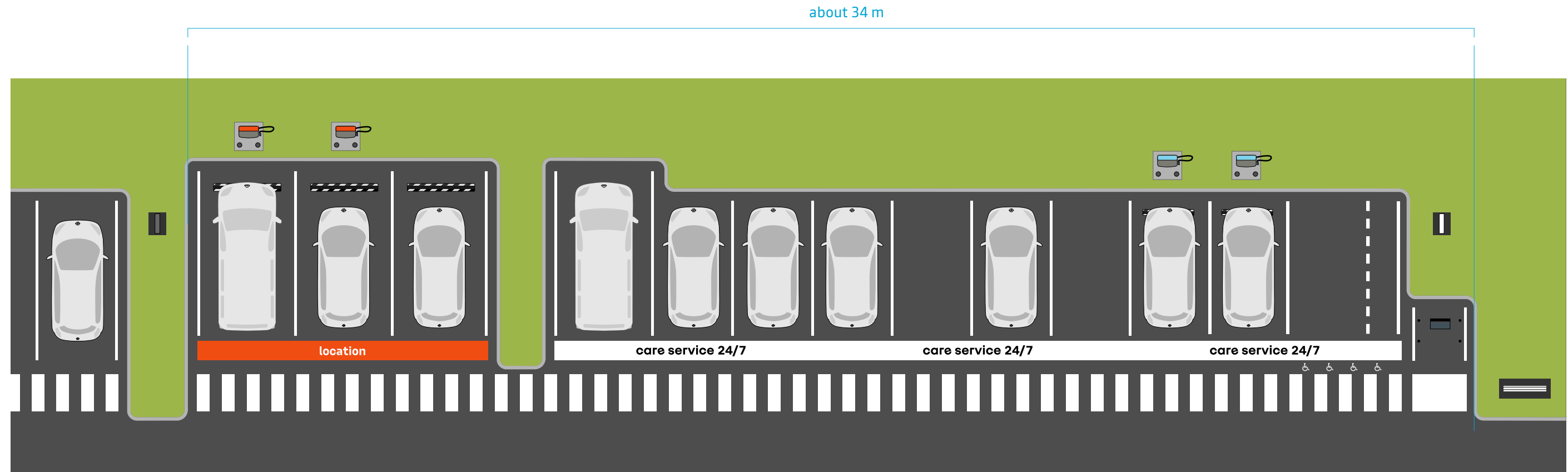

### DESCRIPTION

**In this configuration, the care service 24/7 & Mobilize share areas occupy an area of around 370 m<sup>2</sup> (excluding traffic).**

This configuration does not include a PMR space because it is accessible in the customer parking lot of the site.

The two zones are separated by a central reservation in order to increase the visibility of each zone.

## 7.2.6 Sizing charts

\* workshop customer entries per day excluding bodywork

	up to 10 entries *	from 10 to 20 entries *	from 20 to 30 entries *	comments
Large parking spaces	1	2	3	Generalization of large-format parking spaces for greater versatility aimed at accommodating private vehicles and utility vehicles.
Ground markings	1	1	1	Ground markings are done with a stencil for lettering and pictograms or using a machine for straight strips.
Charging station	1	1	2	Number of charging stations may change over time depending on the degree of electrification of the vehicle fleet (drawing for expansion during implementation).
Airport mast	1	1	1	Non-priority area mast in case of choice of a single area mast for reasons of local regulations
Flag	1	1	1	Standard is used when it is not possible to install an area mast.

mandatory  
 optional

### LAYOUT PRINCIPLE

Capacity of the Mobilize share zone and the configurations are adapted according to the number of workshop entries/day of each of the sites.

## 7.2.7 Integration into the general drawing

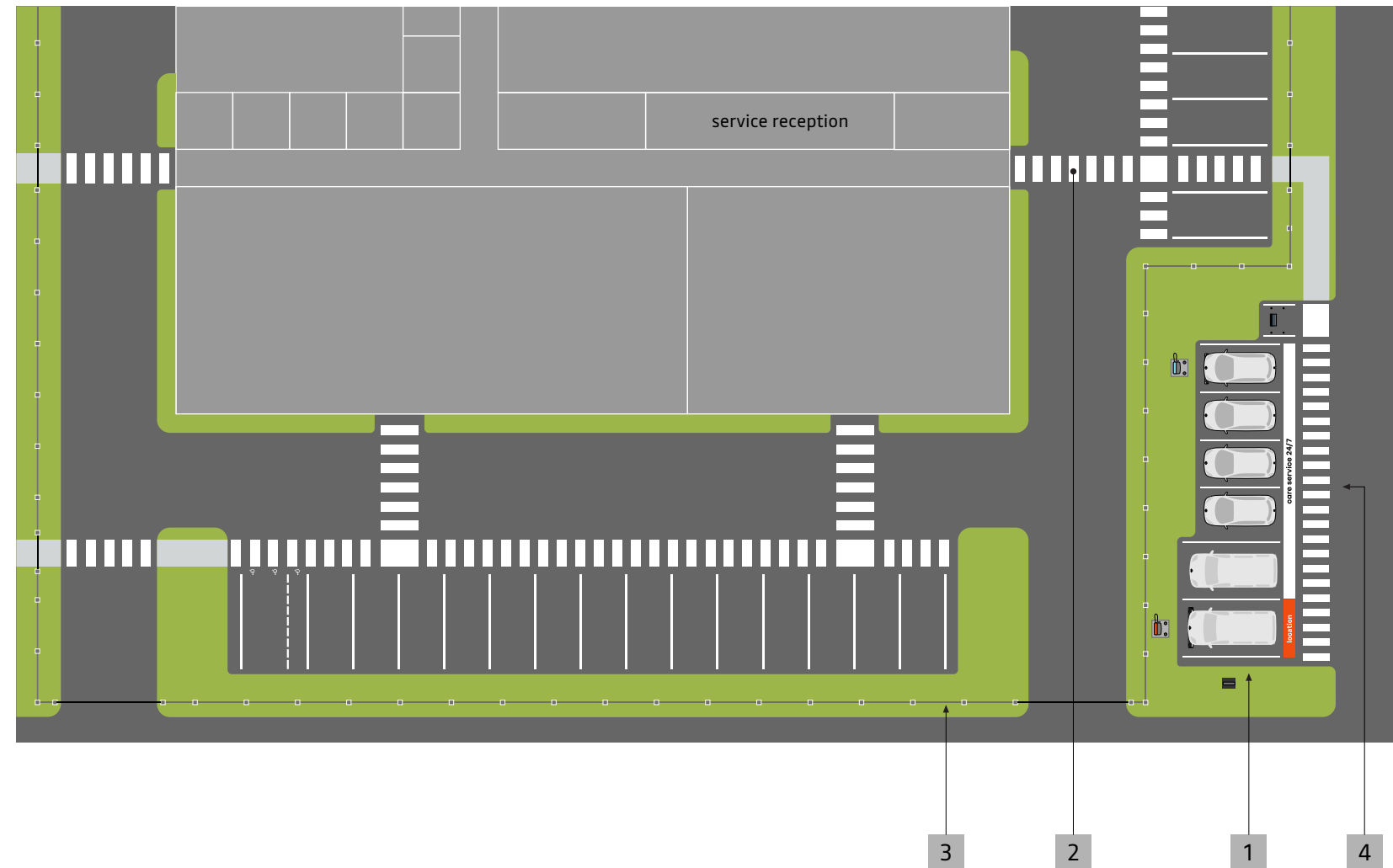

### IMPLEMENTATION PRINCIPLES

**Due to its function, the Mobilize share zone is integrated into the care service 24/7 zone.**

- 1 Mobilize share zone is located outside the protected perimeter of the site to allow access at any time of the day.
- 2 Circulation aisle.
- 3 Site protection perimeter.
- 4 Care service 24/7 zone.

7.3

24/7 MOBILIZE CHARGING STATION ZONE

## 7.3.1 Fundamentals

### **Generic principle**

24/7 Mobilize charging station zone is integrated into the care service 24/7 zone.

Mobilize power solutions offer is complementary and distinct from the Mobilize share offer.

Dimensions of the parking spaces can be adapted to utility vehicles.

### **Possible adaptation**

As an option, a specific rapid charging shade can be used to increase the visibility of the rapid charging offer from around the sites.

## 7.3.2 Presentation



### IMPLEMENTATION PRINCIPLES

The Mobilize share and Mobilize charge 24/7 areas are grouped together and integrated into the care service 24/7 zone.

Accessible outside the site's opening hours, these areas are connected to the service reception by a pedestrian path leading to a glass door on the side facade.

The areas are identified by ground markings.

- 1 Care service 24/7 zone.
- 2 Mobilize share area.
- 3 Mobilize charge 24/7 area.
- 4 Access door to the service reception area.
- 5 Sunshade with identification (optional).



### 7.3.3 Signage items

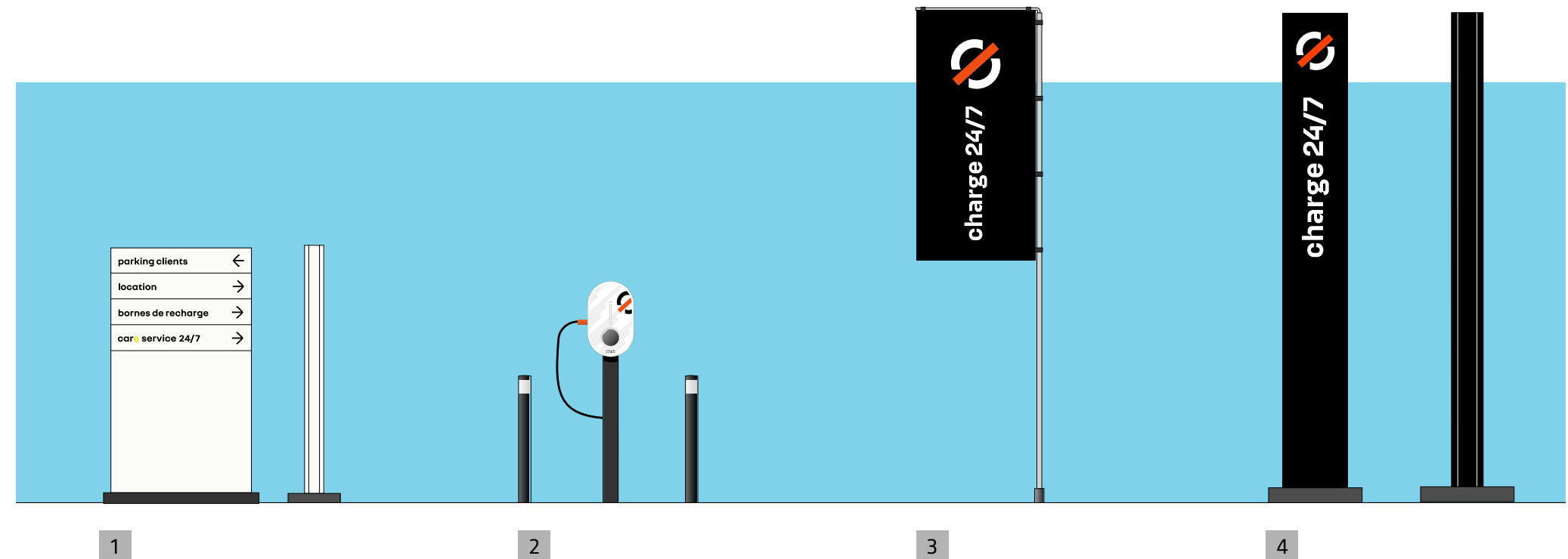

#### IDENTIFICATION PRINCIPLES

The identification of the 24/7 Mobilize charge station is based on the use of signage supports allowing it to integrate harmoniously into the surroundings of multi-brand sites while offering it high visibility.

As an option, a shade canopy can shelter the independent lounge charging area can be offered to customers of the charging service.

- 1 Directional sign.
- 2 Charging station.
- 3 Identification banner (option).
- 4 Area mast.

## 7.3.4 Standard car parks

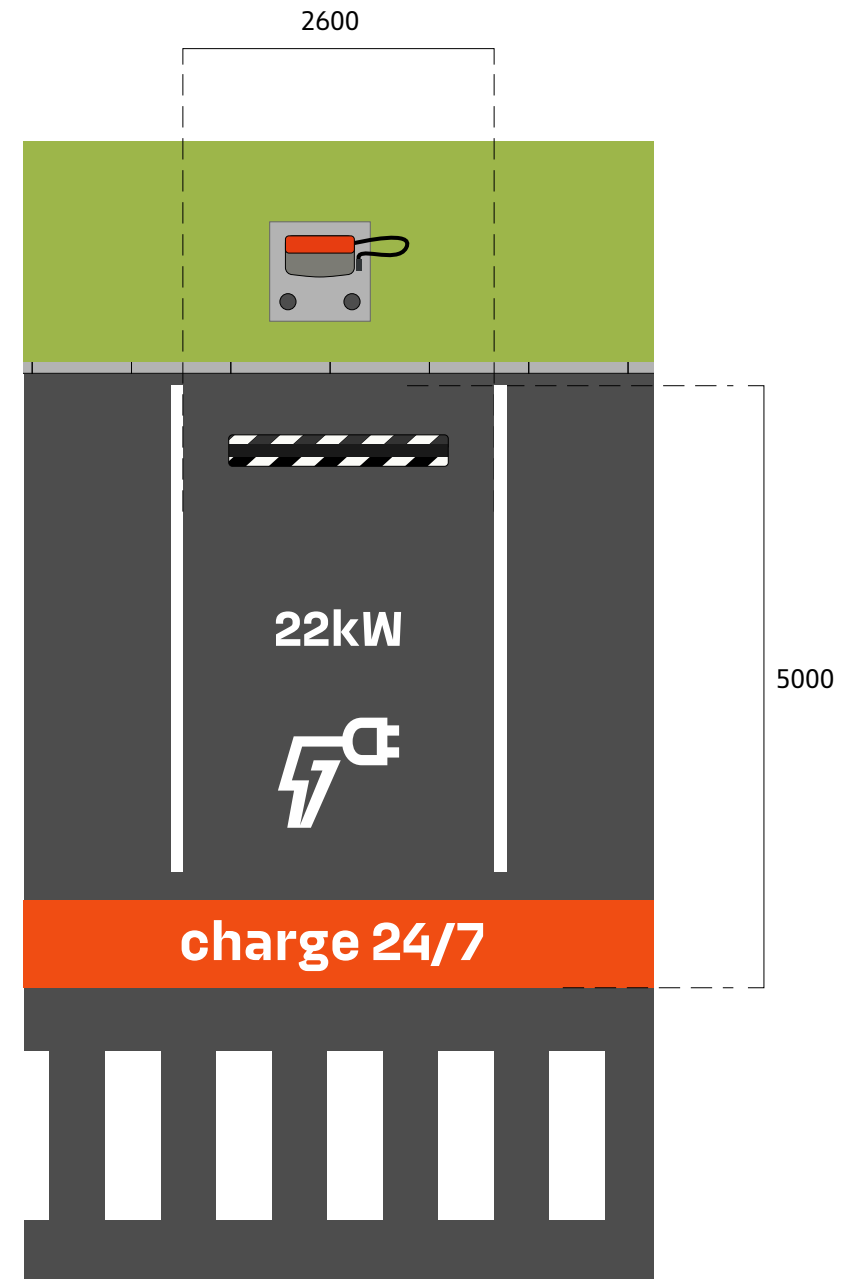

### IDENTIFICATION PRINCIPLES

Standard parking spaces have a 2800 x 5000 mm format.

Parking spaces dedicated to fast charging are identified by the power marking on the ground.

1 Standard 24/7 Mobilize charging station zone.

### 7.3.5 LCVs car park

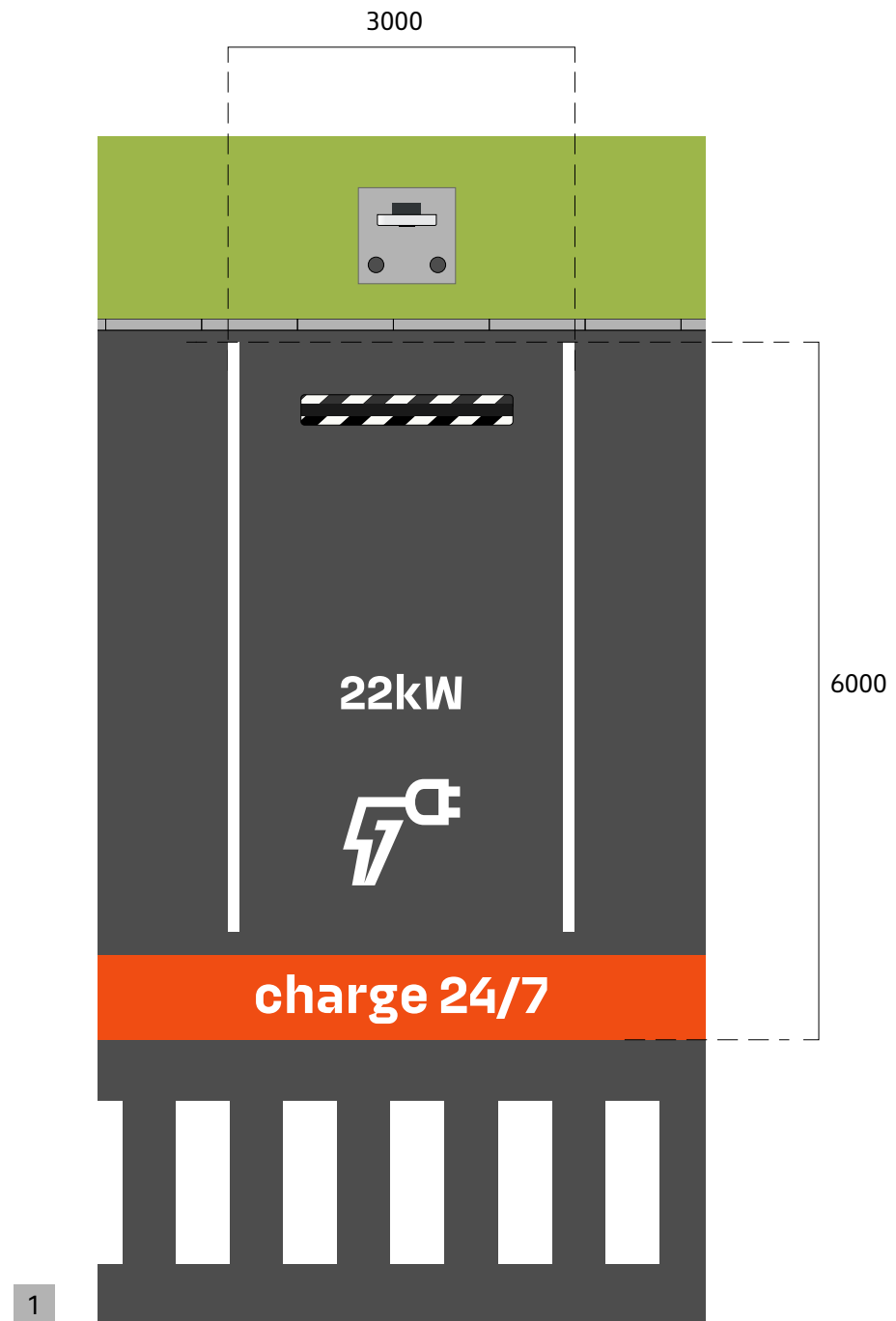

#### IDENTIFICATION PRINCIPLES

The parking areas dedicated to charging LCVs have a larger dimension than standard spaces with a format of 3000 x 6000 mm.

1 24/7 Mobilize charging station zone for LCVs

### 7.3.6 Juxtaposition of 22 kW and 320 kW charging stations

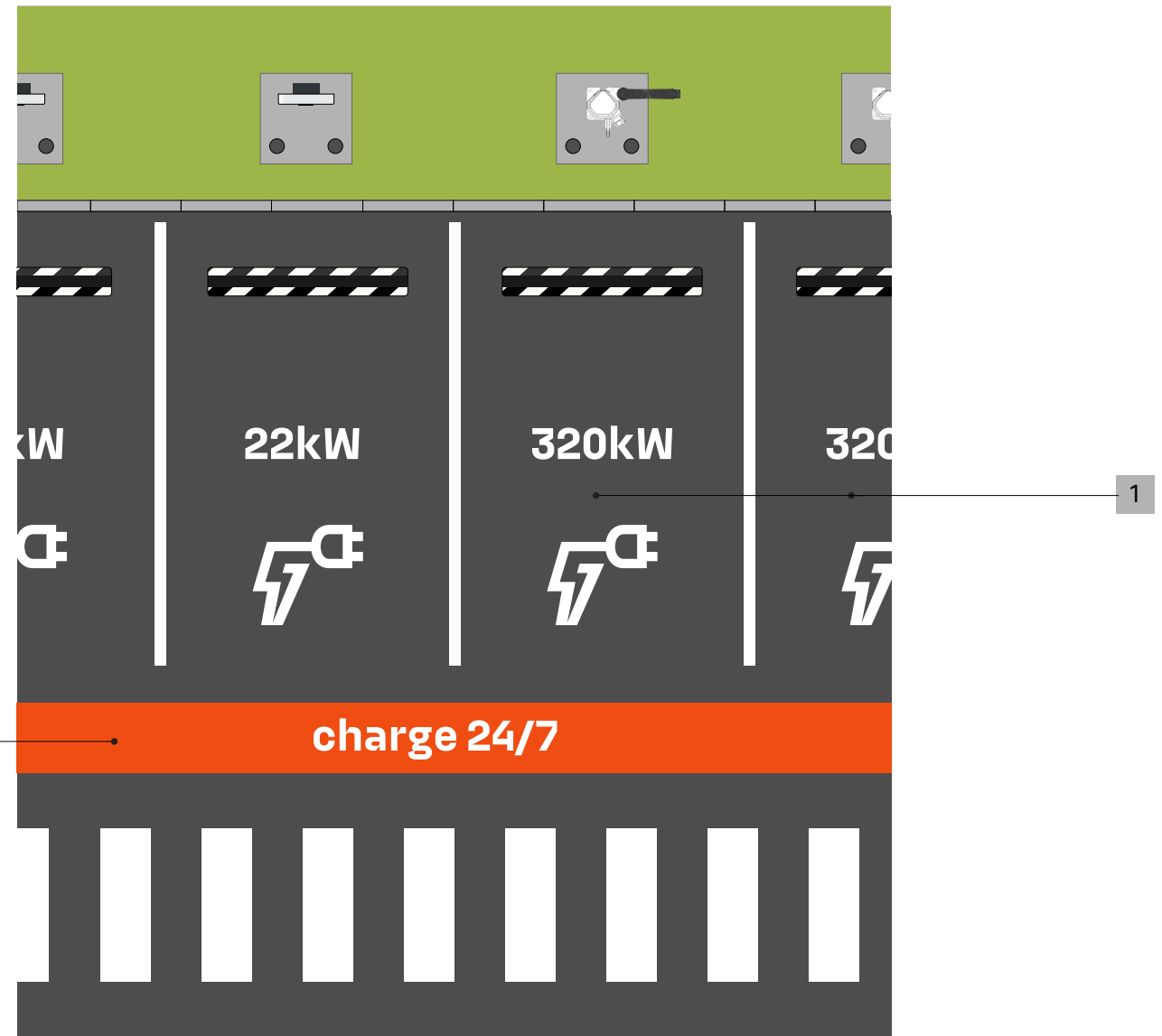

#### IDENTIFICATION PRINCIPLES

It is possible to combine 22 kW and 320 kW charging stations in the same parking area.

In this case, the following rules apply:

- 1 The 320 kW charging stations are grouped together (they do not surround a 22 kW charging station).
- 2 The orange identification strip includes the words "24/7 charging".

### 7.3.7 Integration of a 24/7 Mobilize charging station zone into the general drawing

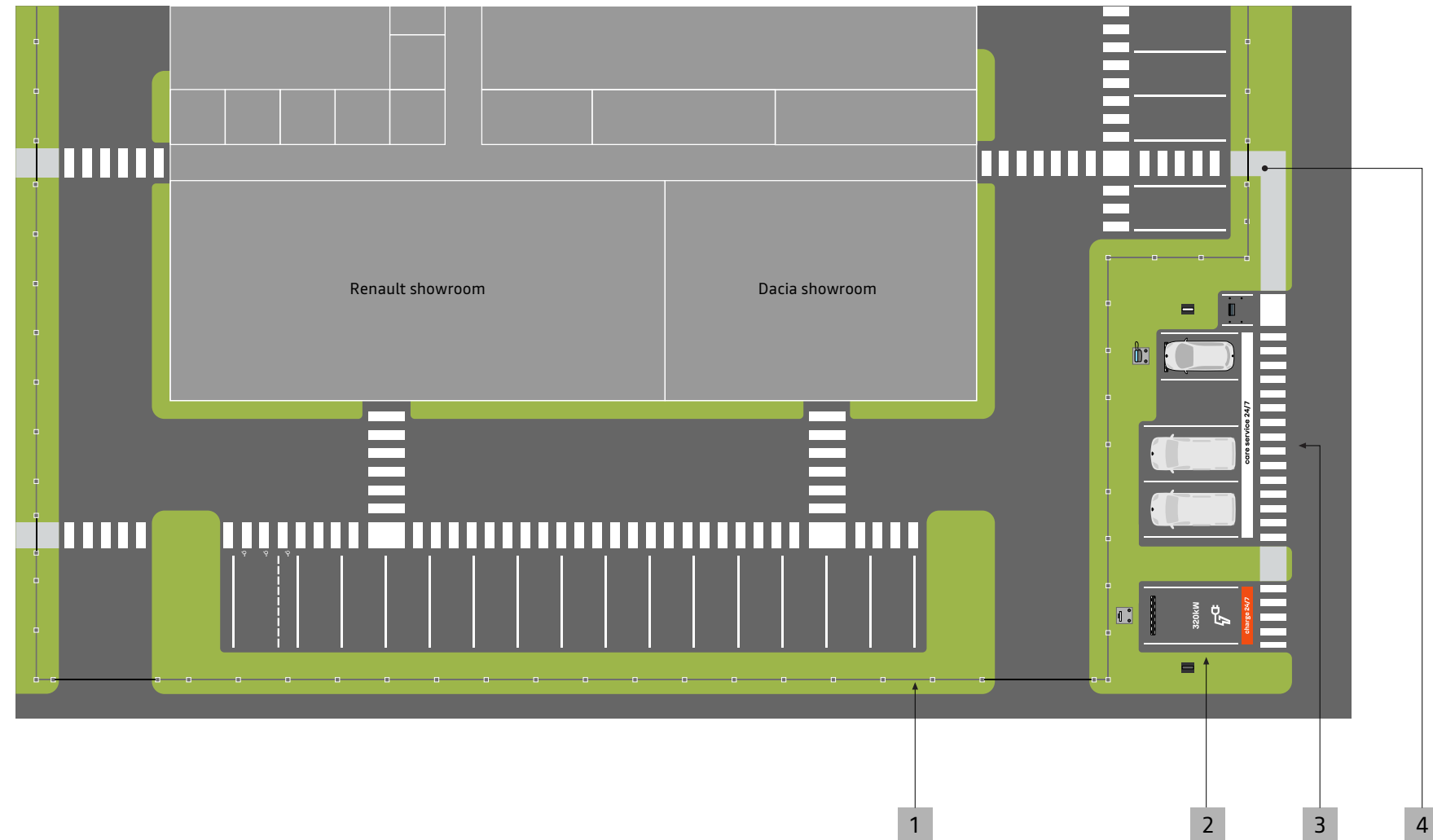

#### IMPLEMENTATION PRINCIPLES

**24/7 Mobilize charging station zone is integrated into the care service 24/7 zone.**

- 1 Site protection perimeter.
- 2 24/7 Mobilize charging station zone is located outside the protected perimeter of the site to allow access at any time of the day.
- 3 Care service 24/7 zone.
- 4 Circulation aisle.

### 7.3.8 Integration of 24/7 Mobilize charging station and Mobilize share zones into the general drawing

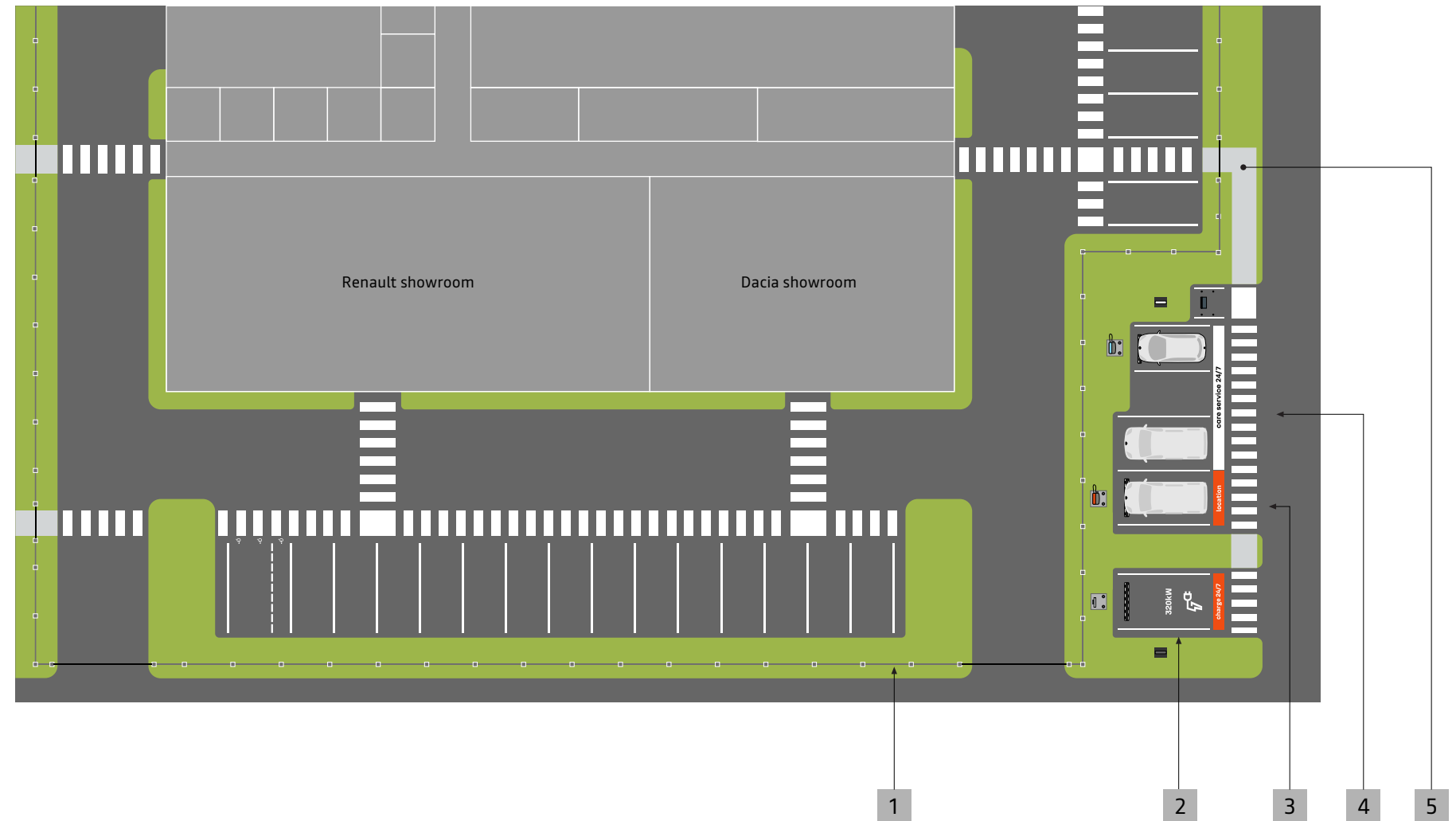

#### IMPLEMENTATION PRINCIPLES

The Mobilize fast charge zone is integrated into the care service 24/7 zone and located as close as possible to the Mobilize share zone when it exists.

- 1 Site protection perimeter.
- 2 24/7 Mobilize charging station zone is located outside the protected perimeter of the site to allow access at any time of the day.
- 3 Mobilize share zone.
- 4 Care service 24/7 zone.
- 5 Circulation aisle.

# 7.4

JOINT IMPLEMENTATION OF DIFFERENT ACTIVITIES

## 7.4.1 Fundamentals

### **Generic principle**

The Mobilize share and 24/7 Mobilize charging station zones can be integrated into the care service 24/7 zone.

These 2 zones are located side by side to make it easier for customers to read the different activities.

Depending on the space available, these 2 zones can be juxtaposed or highlighted by a physical separation of the different activities.

### **Possible adaptation**

Layouts are adapted to the shape and available surface area of each site.



## 7.4.2 General layout of care service 24/7 et Mobilize share zones

### IMPLEMENTATION PRINCIPLES

For greater efficiency and with a view to optimizing costs, it is recommended to integrate the Mobilize share zone into the care service 24/7 zone.

The following components make up this common area:

- 1 Mobilize share zone.
- 2 Care service 24/7 zone.
- 3 Pedestrian path.
- 4 Key box.
- 5 Optional access control.
- 6 Protected enclosure at the site's choice.

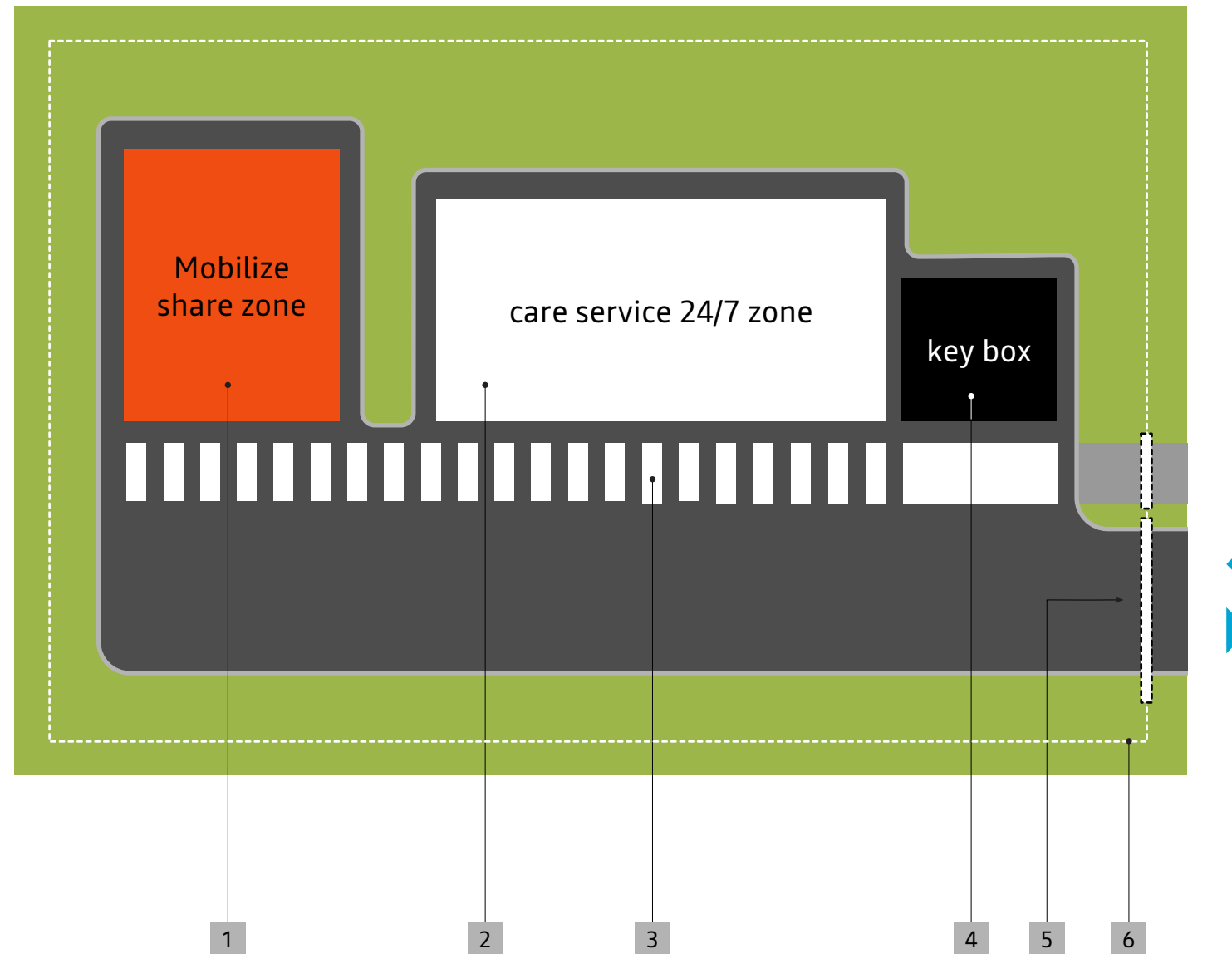

### 7.4.3 General layout care service 24/7 et Mobilize charge 24/7 zone

#### IMPLEMENTATION PRINCIPLES

**Accessible outside of site opening hours, the 24/7 Mobilize charging station zone can be integrated into the care service 24/7 zone.**

It should be noted that non-monetized terminals may be present in the care service 24/7 zone.

The following components constituting this common area are:

- 1 Mobilize charging station.
- 2 24/7 Mobilize charging station zone.
- 3 Non-monetized charging station.
- 4 Care service 24/7 zone.
- 5 Pedestrian path.
- 6 Key box.
- 7 Optional access control.
- 8 Protected enclosure at the site's choice.

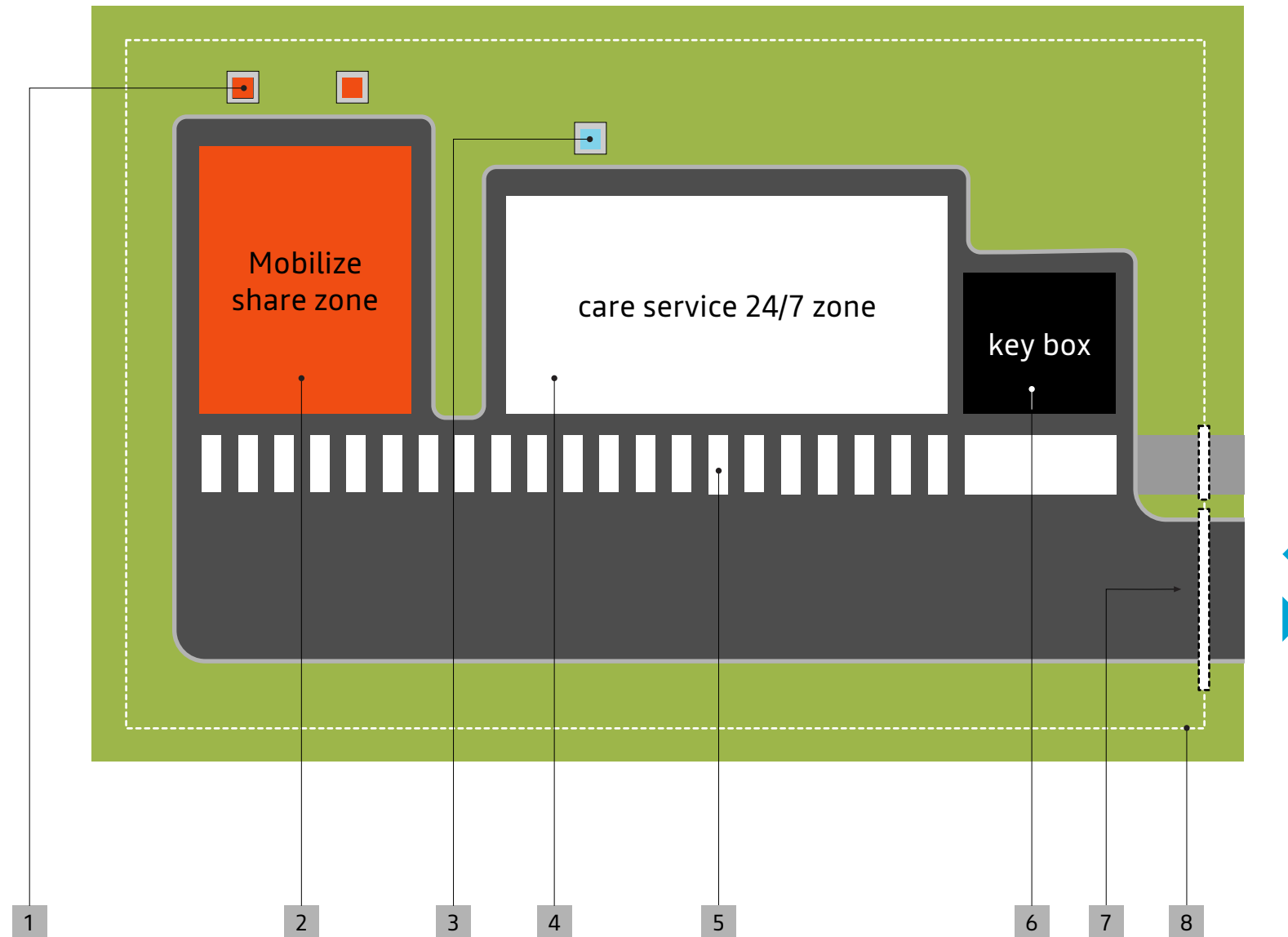

## 7.4.4 Layout examples

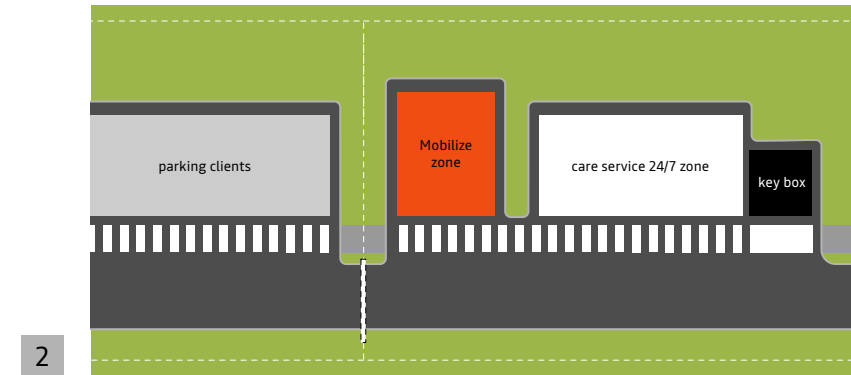
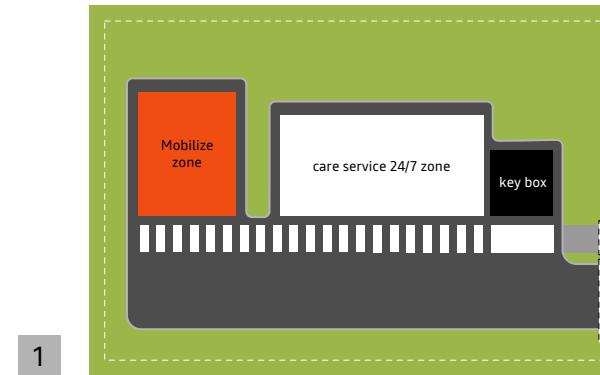

### IMPLEMENTATION PRINCIPLES

The diagrams opposite illustrate different cases of implementation of the care service 24/7 zone associated with a Mobilize share or Mobilize fast charge zone.

It is recommended to separate these zones by a central reservation in order to mark the difference between the activities present in a common area accessible 24/7.

- 1 Separate implementation of the site.
- 2 Integration of the zone in the continuity of the customer parking lot with double enclosure.
- 3 Implementation of the zone with central circulation.
- 4 Alternative implementation of the zone with central circulation.
- 5 Implementation opposite the Mobilize and care service 24/7 zones.

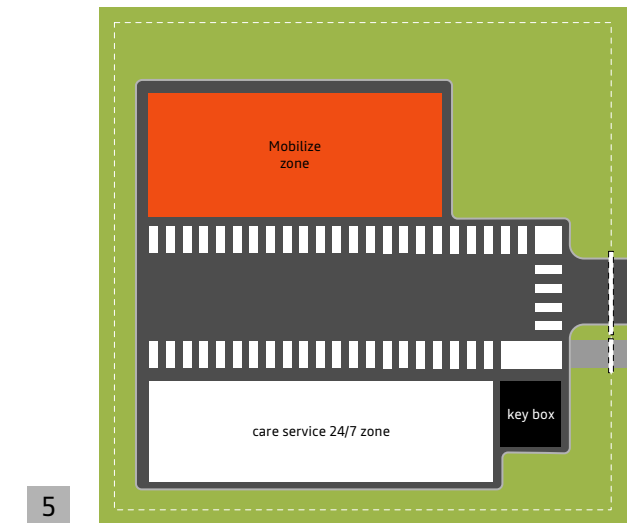
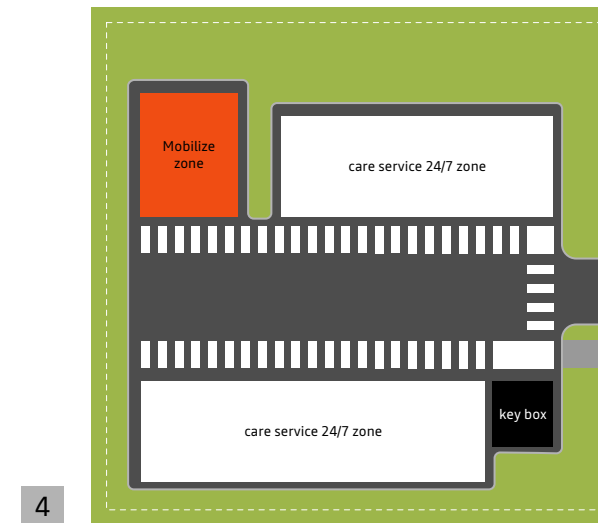
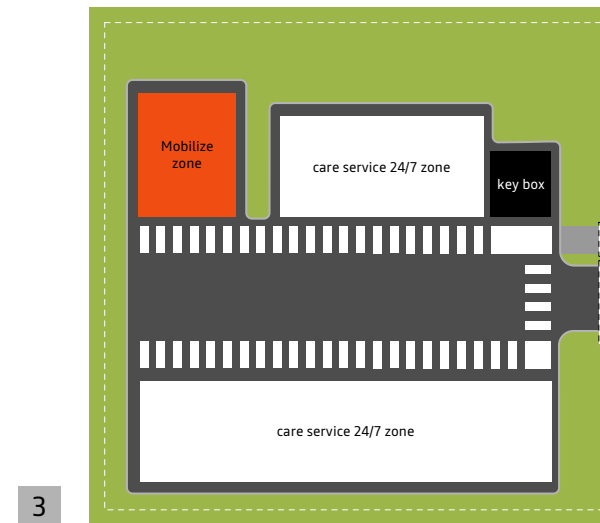

## 7.4.5 General layout of care service 24/7, Mobilize share & Mobilize charging station zones

### IMPLEMENTATION PRINCIPLES

24/7 Mobilize charging station zone can be integrated into the care service 24/7 zone alongside the Mobilize share zone.

It is recommended to group the 2 Mobilize zones in order to simplify the reading of the different activities present in the same space.

The following components constituting this common space are as follows:

- 1 Mobilize charging station.
- 2 24/7 Mobilize charging station zone.
- 3 Mobilize share zone.
- 4 Non-monetized charging station.
- 5 Care service 24/7 zone.
- 6 Pedestrian path.
- 7 Key box.
- 8 Optional access control.
- 9 Protected enclosure at the site's choice.

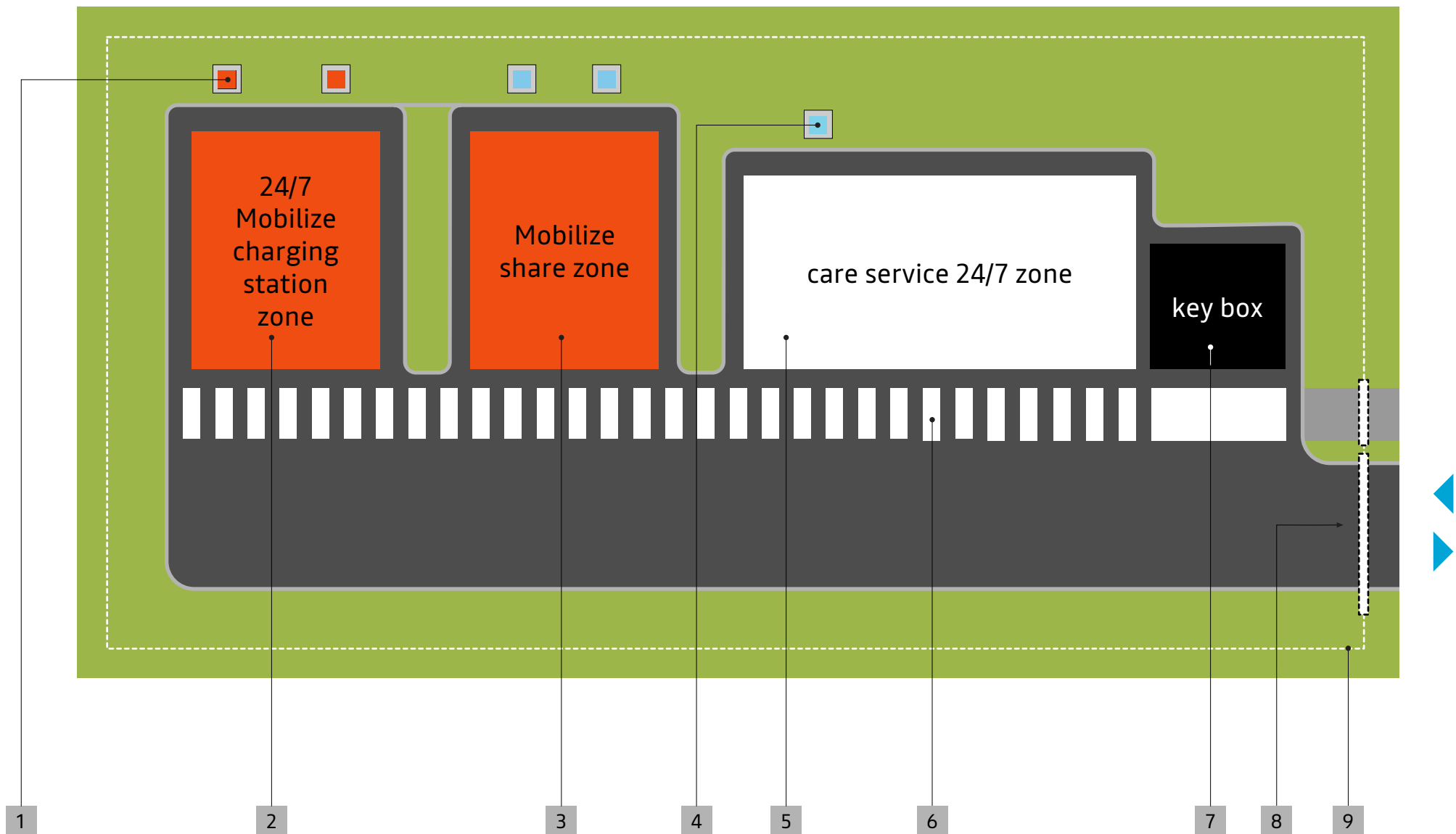

## 7.4.6 Layout examples

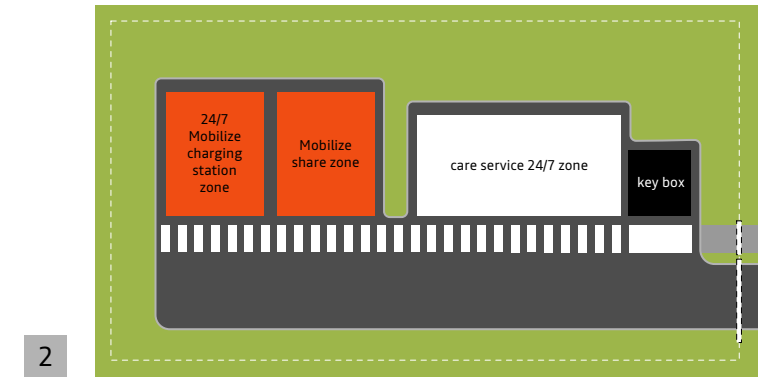
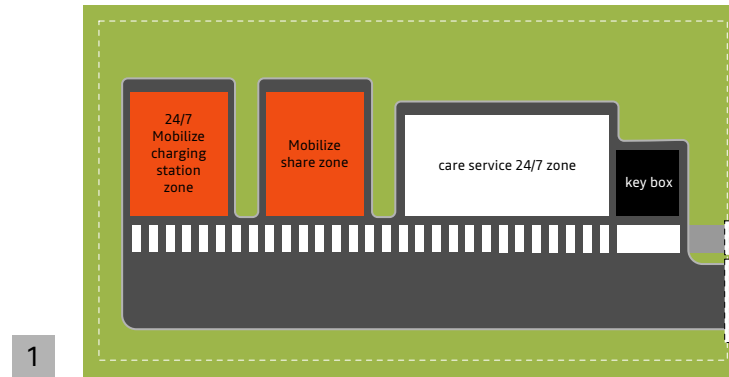

### IMPLEMENTATION PRINCIPLES

The diagrams opposite illustrate different cases of implementation of the care service 24/7 zone associated with the Mobilize share and Mobilize fast charge zones.

It is recommended to separate the Mobilize zones from the care service 24/7 zone by a central reservation in order to mark the difference between the activities present in a common area.

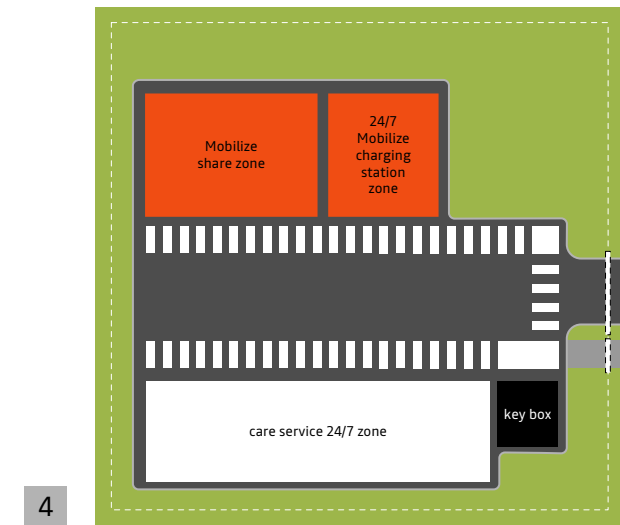
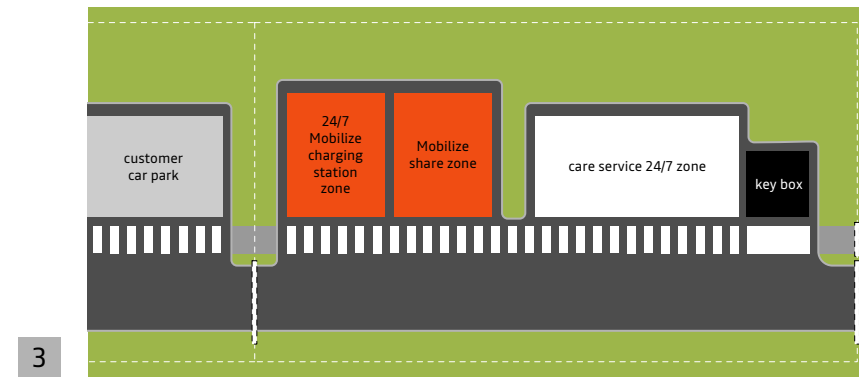

- 1 Separate implementation of the site.
- 2 Juxtaposition of the Mobilize share and 24/7 Mobilize charging station zones.
- 3 Integration of the zone in the continuity of the customer car park with double enclosure.
- 4 Implementation opposite the Mobilize and care service 24/7 zones.

8

RENEW

8.1

RENEW OUTDOOR DISPLAY AREA

## 8.1.1 Fundamentals

### **Generic principle**

The renew outdoor display area is integrated into Renault Group multi-brand sites by offering coherent customer journeys.

This area is preferably located near the Renault showroom to which it is connected by a pedestrian path.

Used vehicle customers access the renew display area directly from the customer parking lot or, where applicable, from the showrooms, by taking the central circulation aisle.

### **Possible adaptation**

Number of vehicles exhibited and size of the renew display area are adapted to each site.

### **Don't**

renew flags must never be mixed with the flags of the brands present on the site.



## 8.1.2 Presentation

### IMPLEMENTATION PRINCIPLES

Used vehicles are presented in the renew outdoor display area.

This area has specific signage elements and, depending on the number of vehicles, an independent sales area.

The renew area is located close to the Renault showroom, to which it is connected by a pedestrian path. A glass door gives visibility to this display area from the showroom.

- 1 Renew display area.
- 2 Identification signage.
- 3 Access door to the Renault showroom.
- 4 Renault showroom.
- 5 Customer car park.



### 8.1.3 Signage items

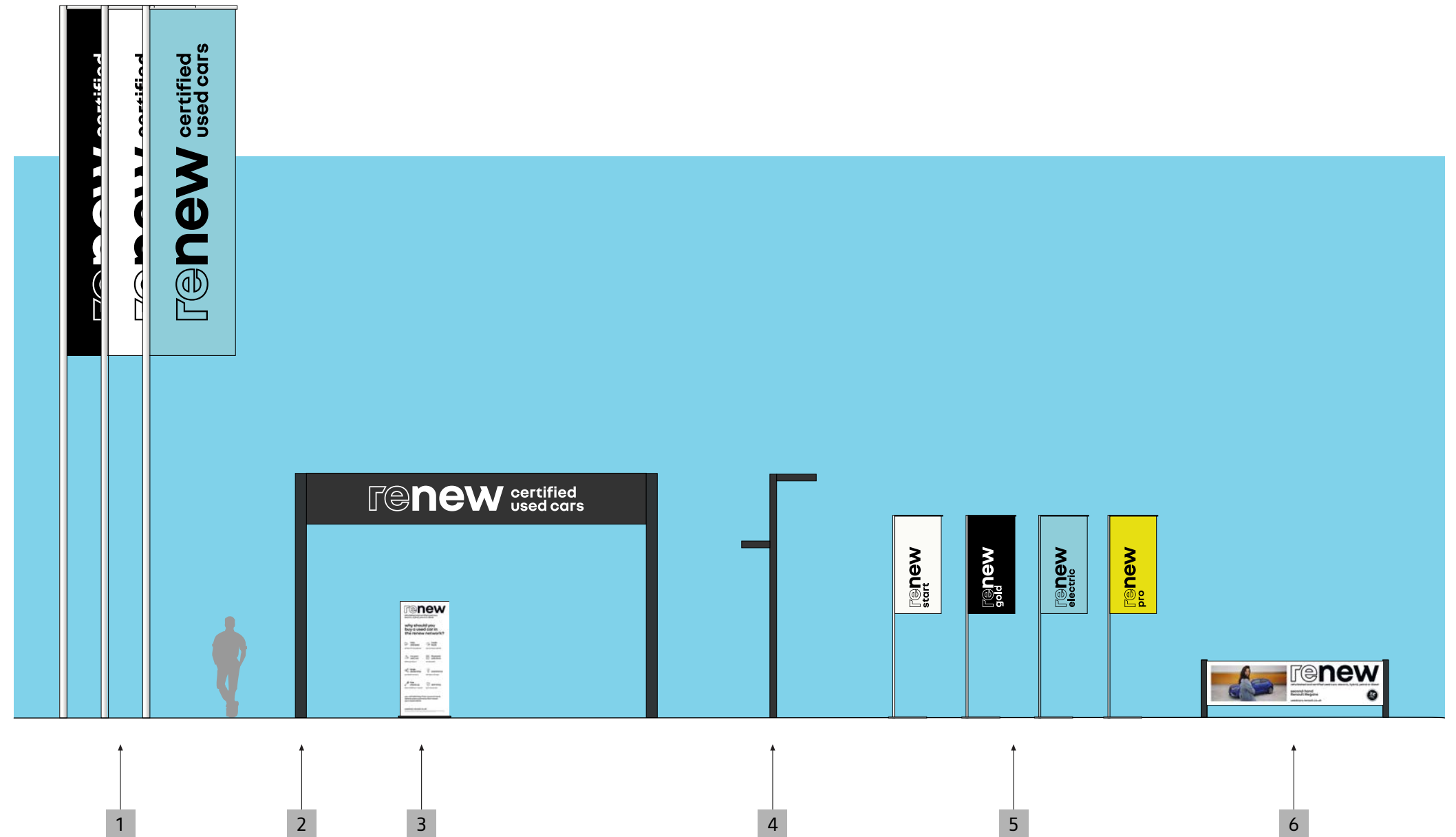

#### IDENTIFICATION PRINCIPLES

renew outdoor display area is identified by specific signage items.

- 1 Flags.
- 2 Arch.
- 3 Customer promise panel.
- 4 Lighting mast.
- 5 Generic standards.
- 6 Promotional banner.

## 8.1.4 General layout

### IMPLEMENTATION PRINCIPLES

The display area is organized around the different segments of the renew offer.

It is fully modular in order to adapt to the spaces available on the sites.

The sales office is generally located in the axis of the central bay.

- 1 Flags.
- 2 Arch.
- 3 Customer promise panel.
- 4 Lighting masts.
- 5 Generic flags.
- 6 Promotional banner.
- 7 Sales office.

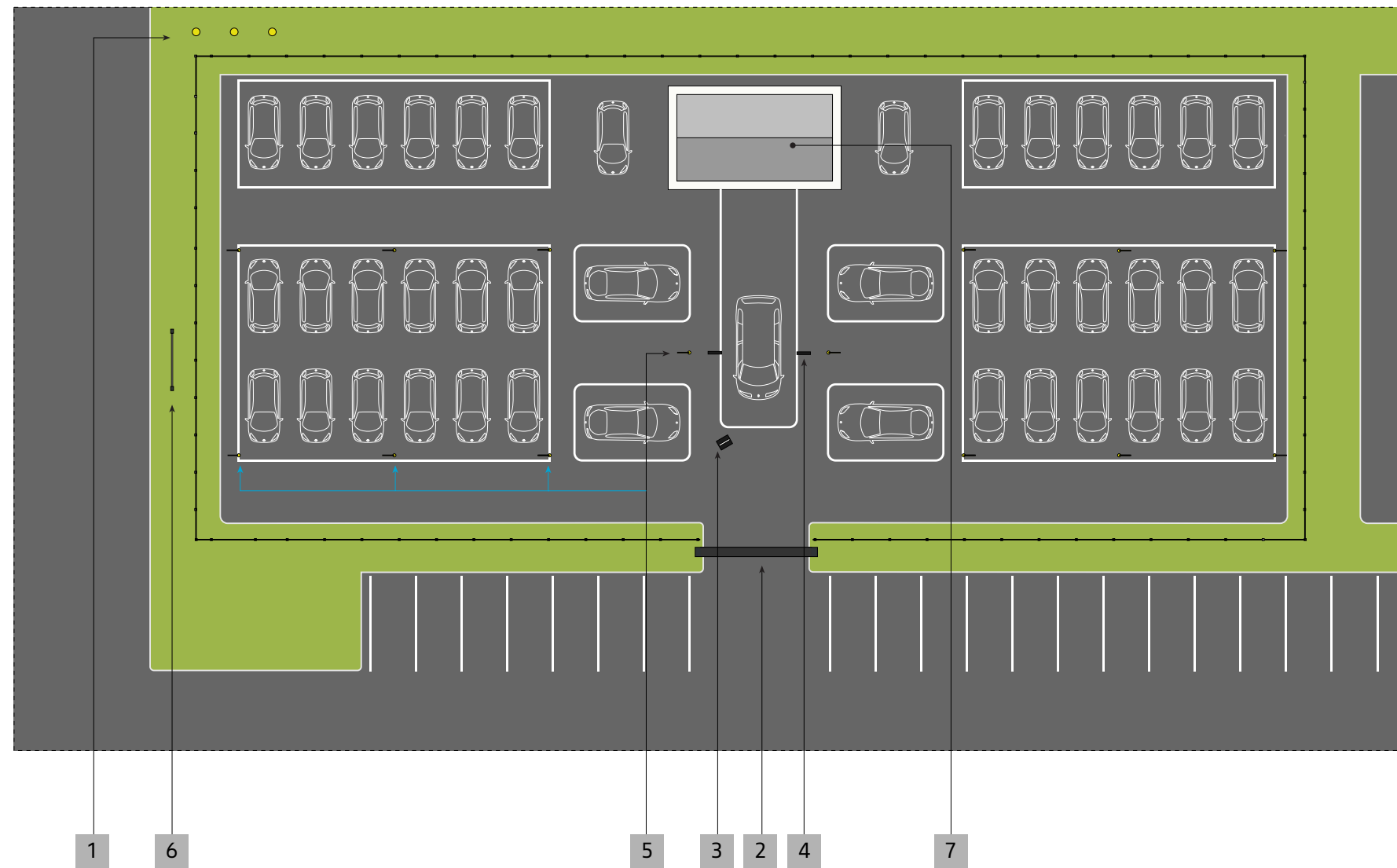

## 8.1.5 Integration into the general drawing

### IMPLEMENTATION PRINCIPLES

The renew display area is located near the Renault showroom. Pedestrian paths connect it to the customer parking lot and the central building.

As an option, a renew sales office can be present in the building integrated into the continuity of the Renault sales offices or in the form of an open office in an island in the Renault showroom.

- 1 Renew sales office in the outdoor display area.
- 2 Renew display area.
- 3 Renew sales office (option) located either in the continuity of the Renault sales offices or in the Renault showroom.
- 4 Renault showroom.
- 5 Customer car park.

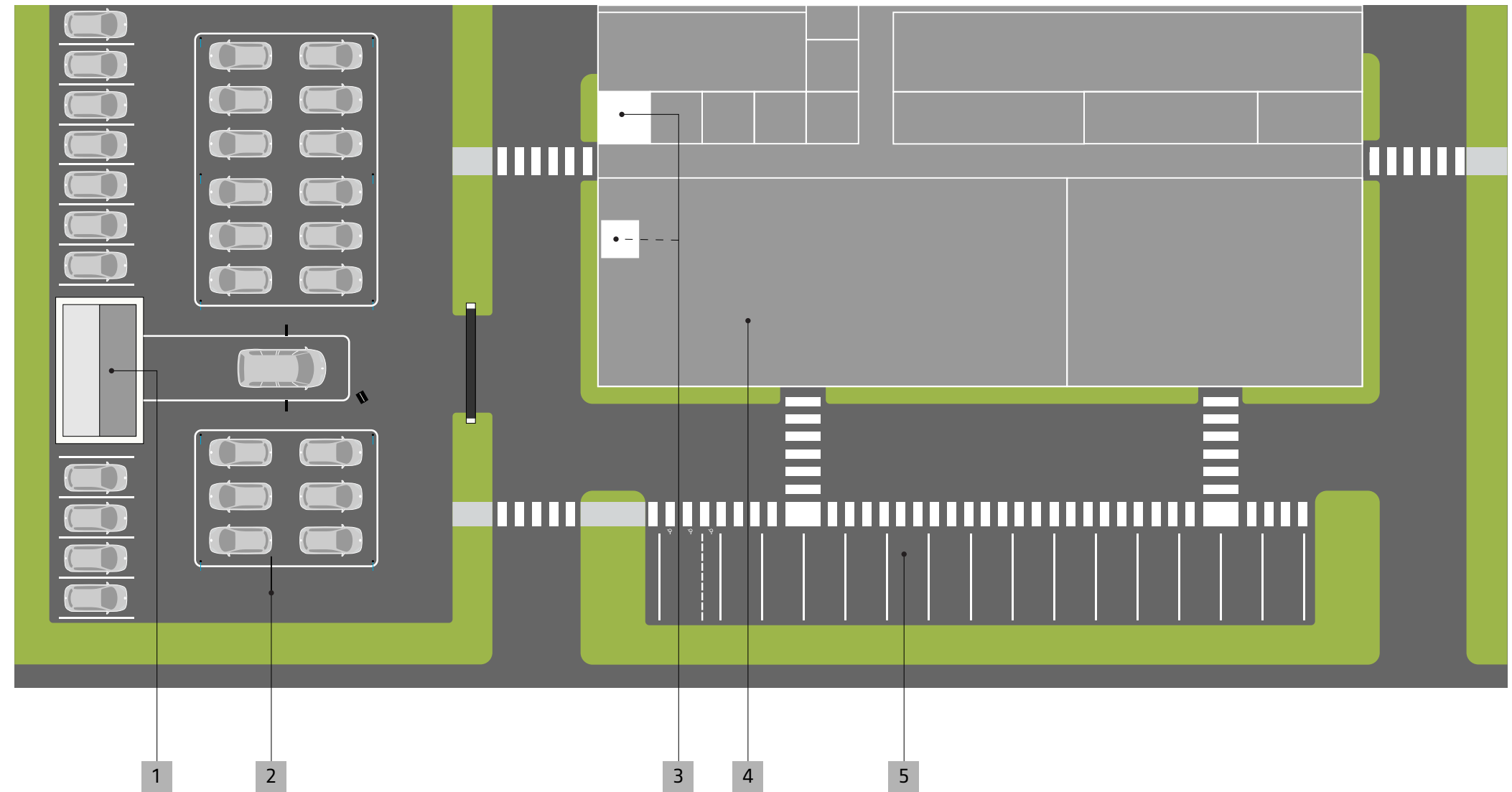

## 8.1.6 The renew flagship zone for less than 5 vehicles

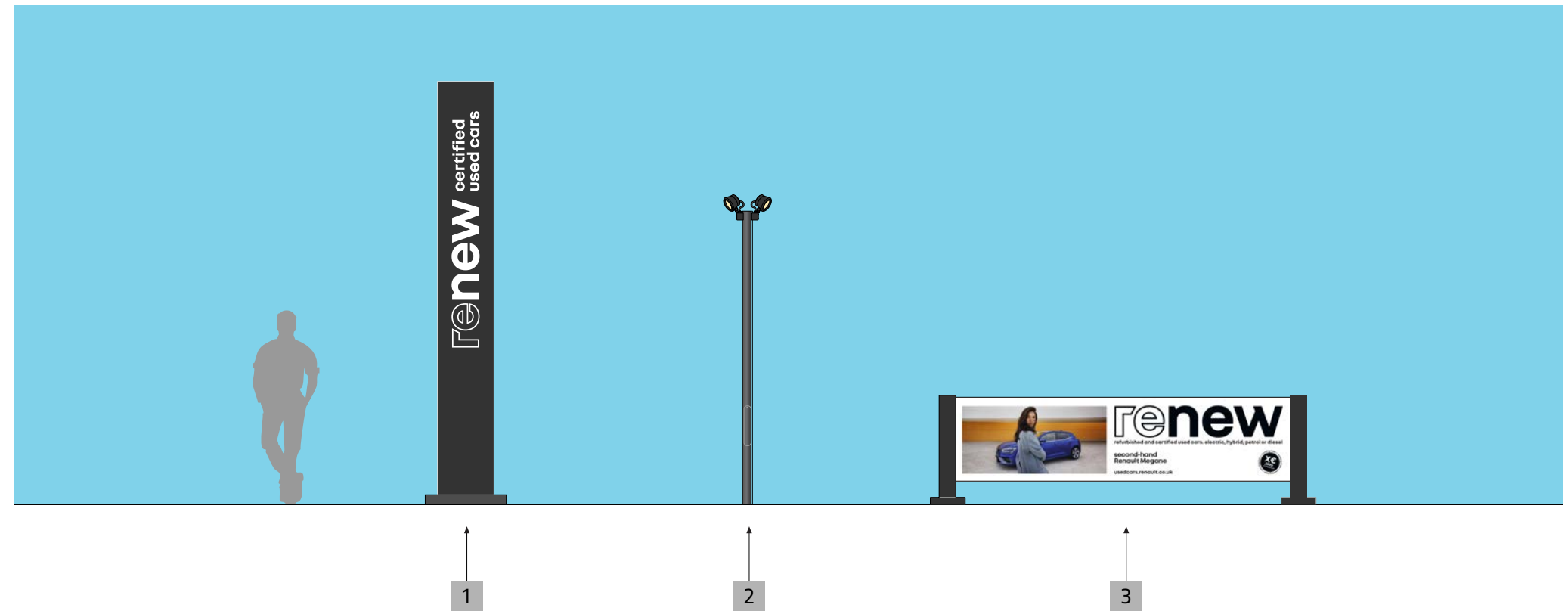

### IMPLEMENTATION PRINCIPLES

In case of lack of space around a site, it will be possible to present used vehicles in a reduced display area area with 1 to 5 vehicles.

It uses the following components:

- 1 Area mast.
- 2 Lighting mast (optional).
- 3 Promotional banner.

## 8.1.7 Integration of the renew flagship zone

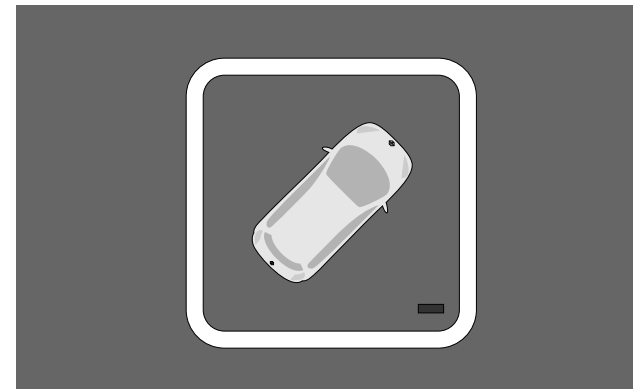

↑  
1

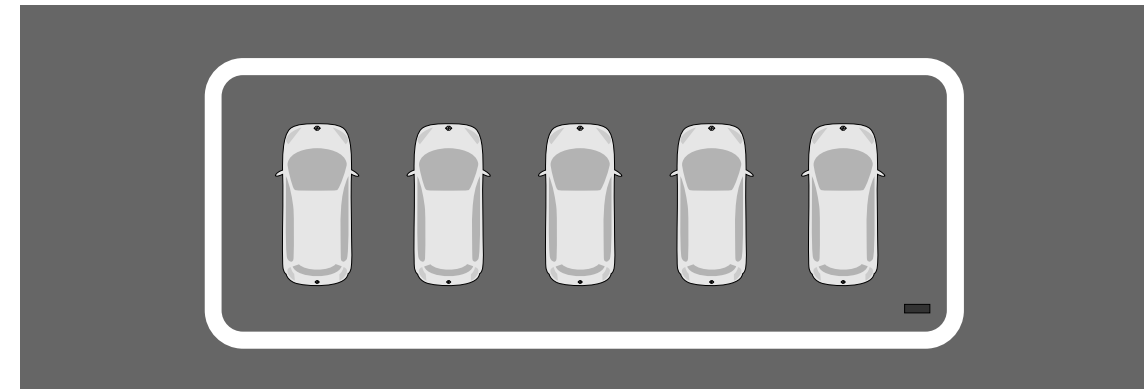

↑  
2

### IMPLEMENTATION PRINCIPLES

**The renew flagship zone can be set up in front or on the sides of the sites but never in front of the new vehicle showroom.**

If necessary, the renew flagship zone is aligned with the other outdoor display area areas.

- 1 renew flagship zone for 1 vehicle.
- 2 renew flagship zone for 5 vehicles.

8.2

RENEW SHOWROOM

## 8.2.1 Fundamentals

### **Generic principle**

renew showroom can be set up alongside the Renault & Dacia showrooms provided that the minimum surface areas allowing the presentation of the entire ranges of the 2 brands are respected.

The pediment of the renew showroom is covered with metal mesh.

The dedicated entrance to the renew showroom is identified by an identification box and a promise panel.

renew showroom is always separated from the Renault & Dacia showrooms, at a minimum, by transparent partitions.

### **Possible adaptation**

Number of vehicles exhibited and size of the renew showroom are adapted to each site according to the commercial potential.

### **Don't**

renew signature must never be installed on the pediment of a multi-brand site.



## 8.2.2 Implementation into the building

### IMPLEMENTATION PRINCIPLES

**renew showroom is integrated alongside the Renault & Dacia showrooms.**

**From the customer parking lot, customers can go directly to this showroom, an entrance door identified as renew being installed on the front.**

The renew sales office is either integrated with the Renault sales offices, or directly in the renew showroom in the form of an open island office.

- 1 Sales office renew.
- 2 Central circulation aisle.
- 3 Renault sales offices.
- 4 Renault showroom.
- 5 Dacia showroom.

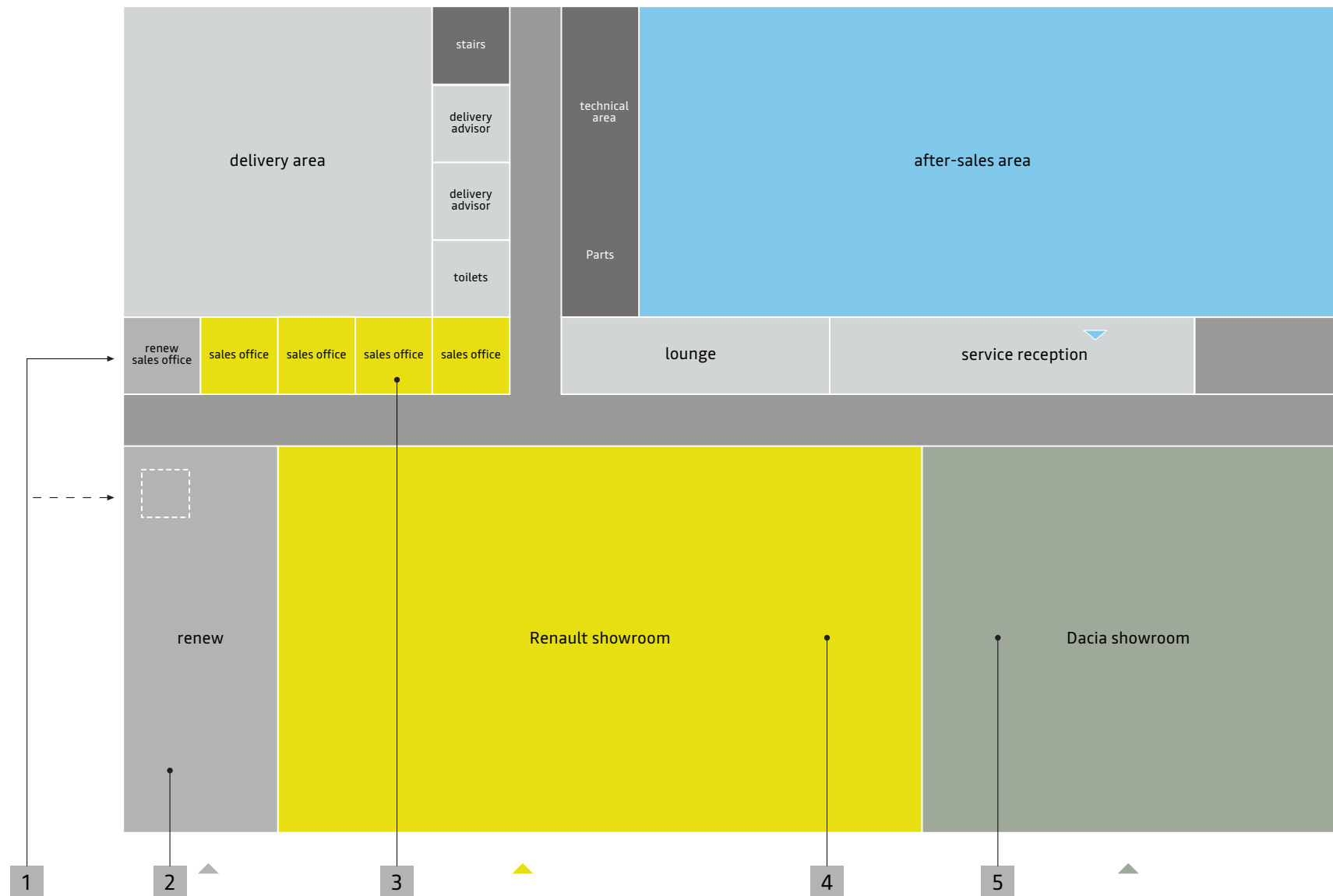

### 8.2.3 Integration of the renew showroom into the building

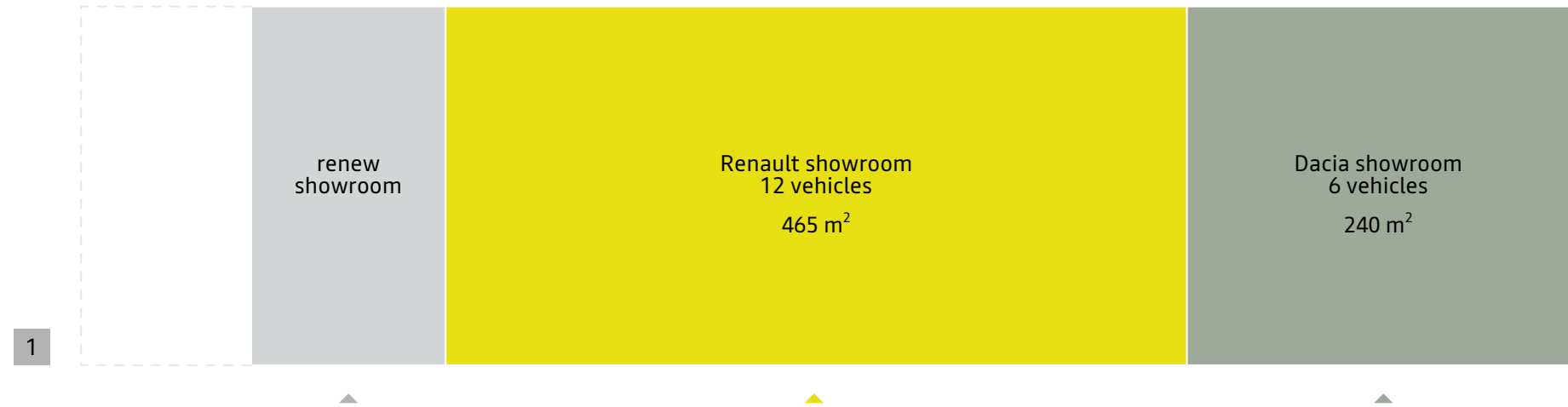

#### INTEGRATION PRINCIPLES

The challenge for the Renault and Dacia brands is to display all the models of their ranges.

If this condition is met, the integration of a renew showroom in the main building is possible.

The surface area allocated to the renew showroom varies depending on the commercial potential of each site.

The examples opposite illustrate the standard surfaces allocated to the showrooms of the Renault & Dacia brands with integration of the renew showroom.

1 Configuration combining 12 Renault vehicles with 6 Dacia vehicles.

2 Configuration combining 8 Renault vehicles with 6 Dacia vehicles.

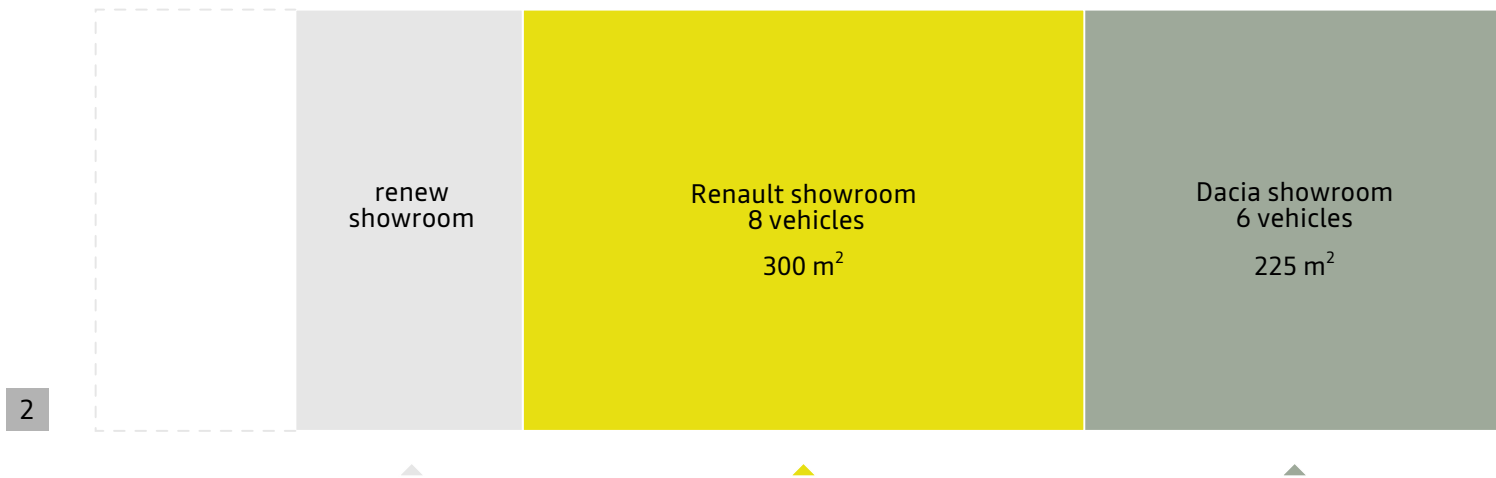

## 8.2.4 renew showroom integration variant



### INTEGRATION VARIANT

**renew showroom can be installed next to the Dacia showroom.**

The examples opposite illustrate the standard areas allocated to the showrooms of the Renault & Dacia brands with integration of the renew showroom.

- 1 Configuration combining 12 Renault vehicles with 6 Dacia vehicles.
- 2 Configuration combining 8 Renault vehicles with 6 Dacia vehicles.

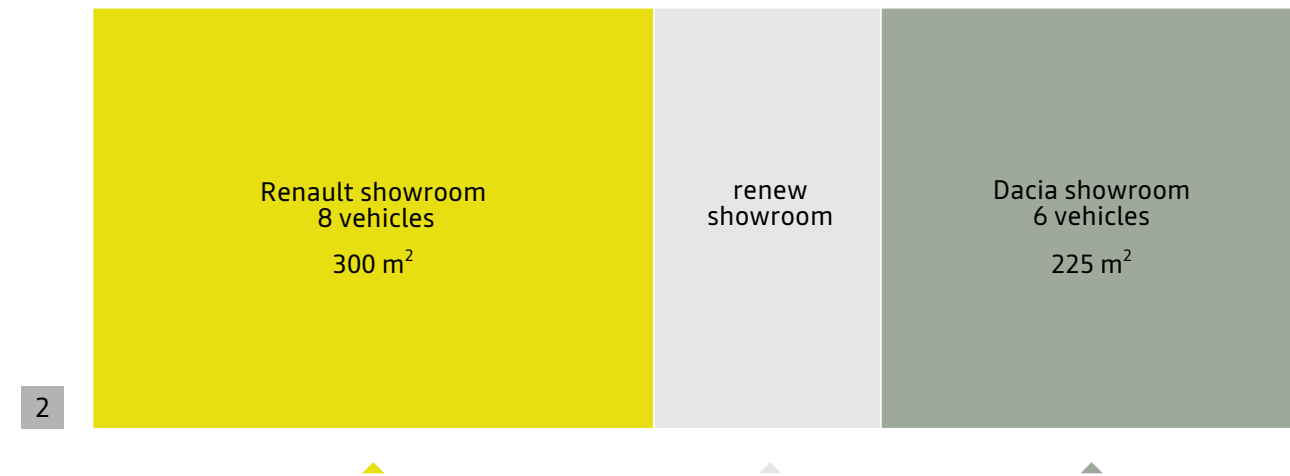

## 8.2.5 Principle of separation of Renault Group brand showrooms

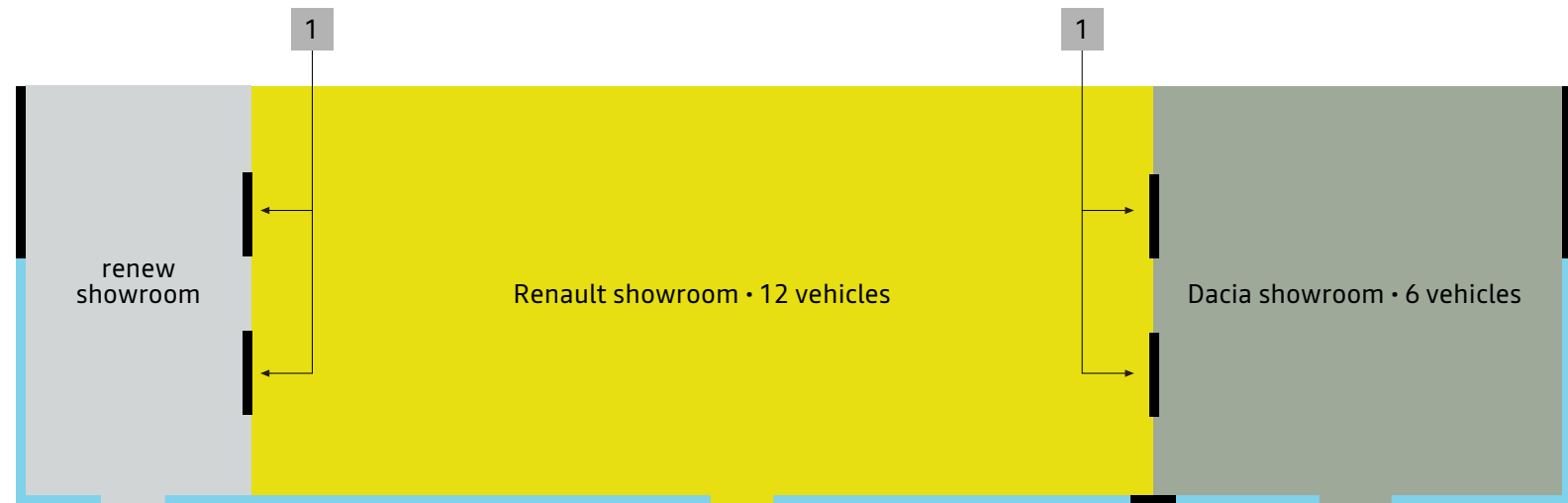

### PRINCIPLES

Transparent partitions separate the 3 showrooms. They are a minimum height of 2.3 m.

These partitions are specific to the Renault Group brand showrooms (with the exception of the Alpine showroom which is always separated by a solid partition).

- 1 Self-supporting transparent partitions.
- 2 These modular partitions ideally cover 2/5 of the depth of the showroom and at least 1/3 of its depth.

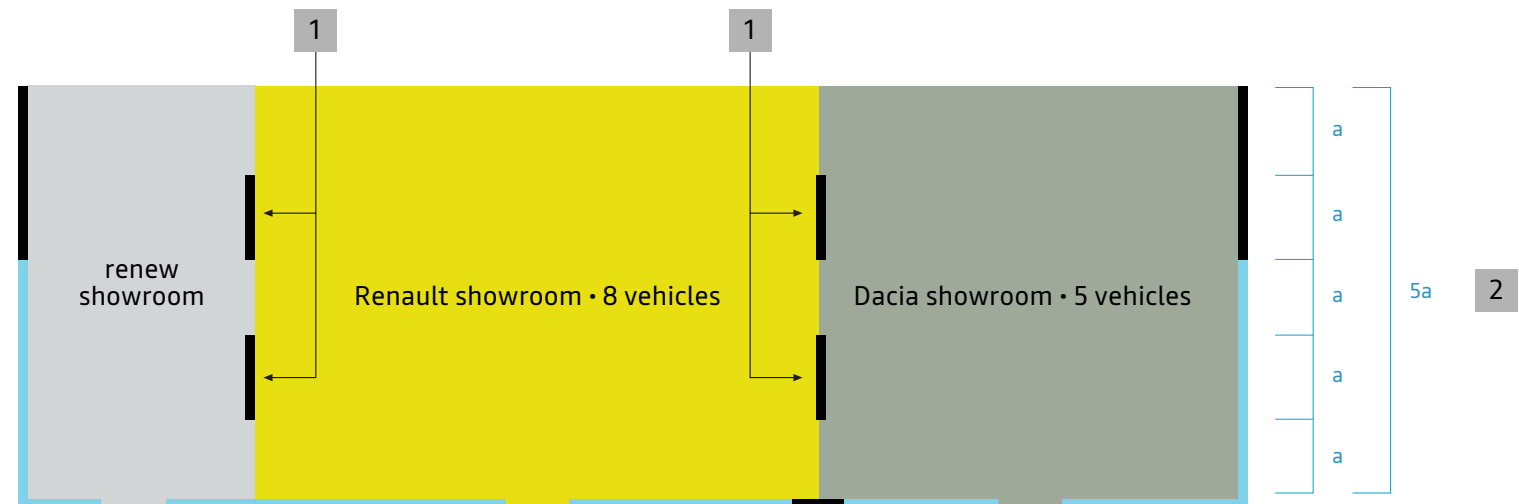

## 8.2.6 The renew showroom facade

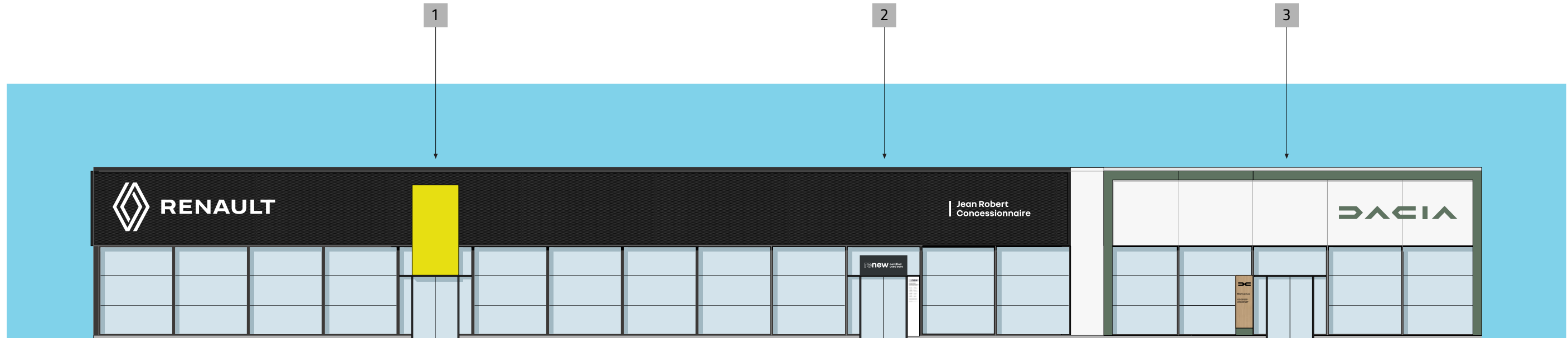

### IDENTIFICATION PRINCIPLES

The presence of renew is identified by the door marking including an identification box associated with a customer promise panel.

The metal mesh covers the pediments of the facades of renew and Renault showrooms.

No separation between the facades of these showrooms is to be expected.

- 1 Entrance to Renault showroom.
- 2 Entrance to renew showroom.
- 3 Entrance to Dacia showroom.

## 8.2.7 The renew showroom facade • Variant

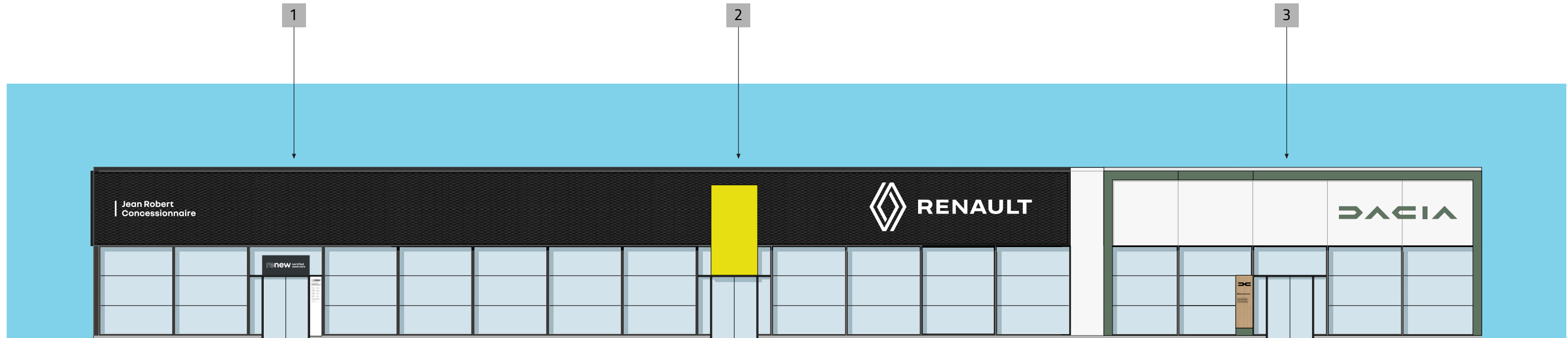

### VARIANT

The illustration opposite shows the case where the renew showroom is located next to the Renault showroom.

The Renault signature on the façade pediment is never positioned above the entrance door of the renew showroom.

- 1 Entrance to Renault showroom.
- 2 Entrance to renew showroom.
- 3 Entrance to Dacia showroom.

9

RENAULT PRO+

9.1

RENAULT PRO+ OUTDOOR DISPLAY AREA



## 9.1.1 Fundamentals

### **Generic principle**

The LCVs are presented in an outdoor display area area identified as Renault Pro+.

This area is preferably located near the Renault showroom to which it is connected by a pedestrian path.

Professional customers access the Renault Pro+ display area directly from the customer car park or, where applicable, from the showrooms, by taking the central circulation aisle.

### **Possible adaptation**

Number of vehicles exhibited and size of the Renault Pro+ display area area are adapted to the commercial potential of each site.

### **Don't**

Renault Pro+ flags must never be mixed with the flags of the brands present on the site.

## 9.1.2 Presentation

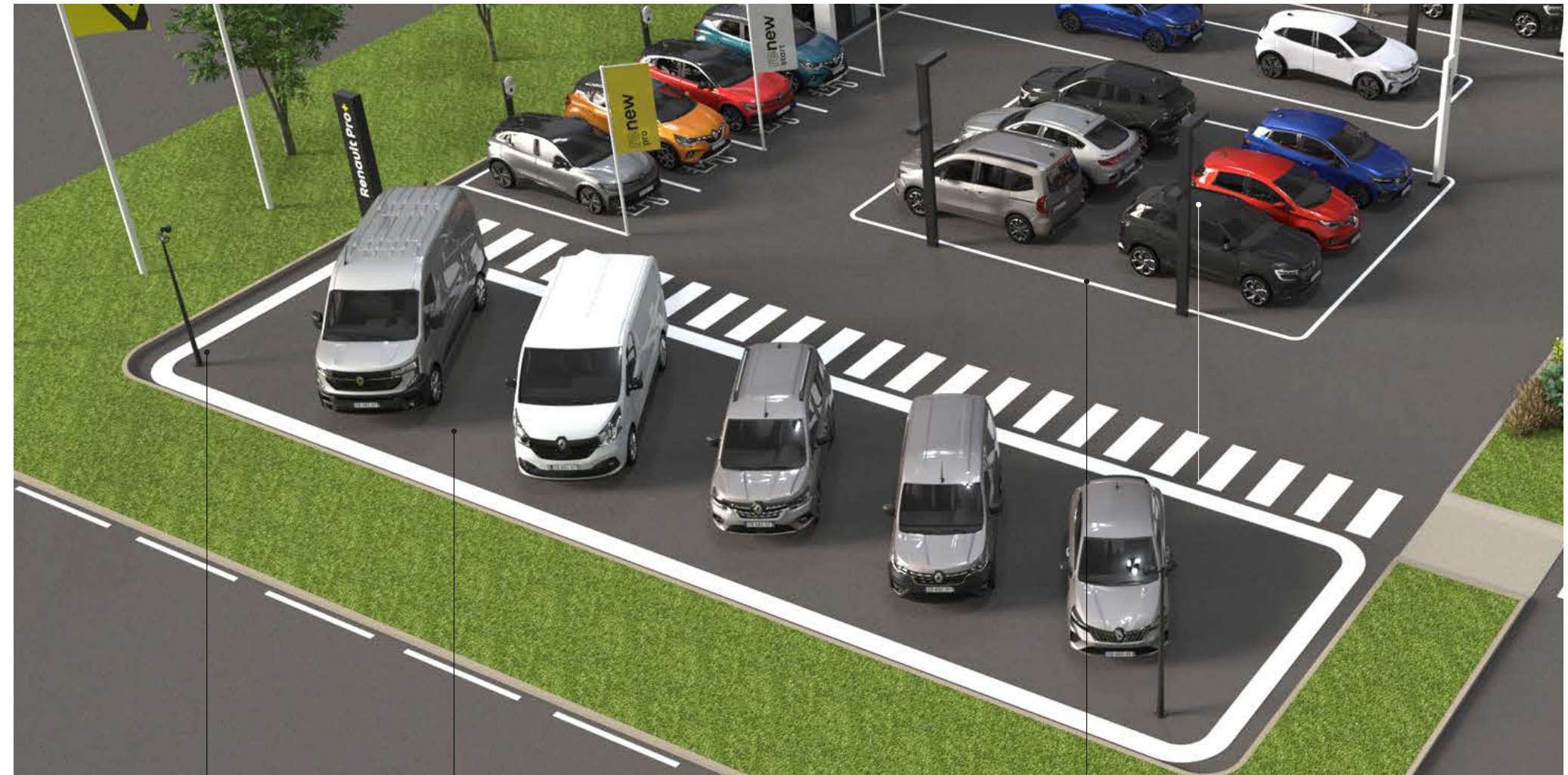

### IMPLEMENTATION PRINCIPLES

LCVs are presented in the Renault Pro+ outdoor display area area.

This area has specific signage elements.

The Renault Pro+ area is located close to the Renault showroom. A pedestrian path connects it to the customer parking lot and the showrooms.

It can coexist with a renew outdoor display area.

1 Renault Pro+ outdoor display area.

2 renew display area.

2

1

2

## 9.1.3 Signage items

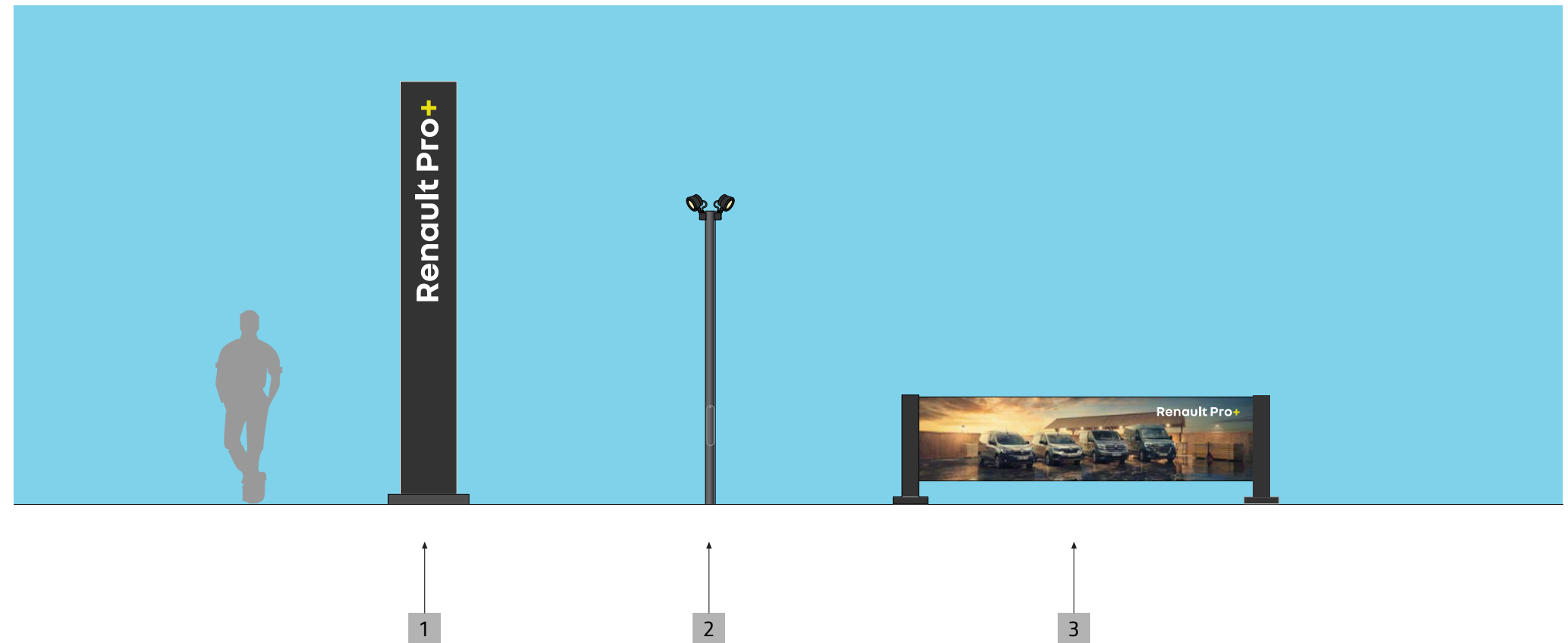

### IDENTIFICATION PRINCIPLES

**Specific components of Renault Pro+ make it possible to identify and animate the display area areas dedicated to LCVs.**

It is recommended to set up an display area area close to the other display area areas (including renew) in order to present the main models in the range.

It uses the following elements:

- 1 Area mast.
- 2 Lighting mast.
- 3 Promotional banner.

## 9.1.4 Typical configuration of the outdoor display area

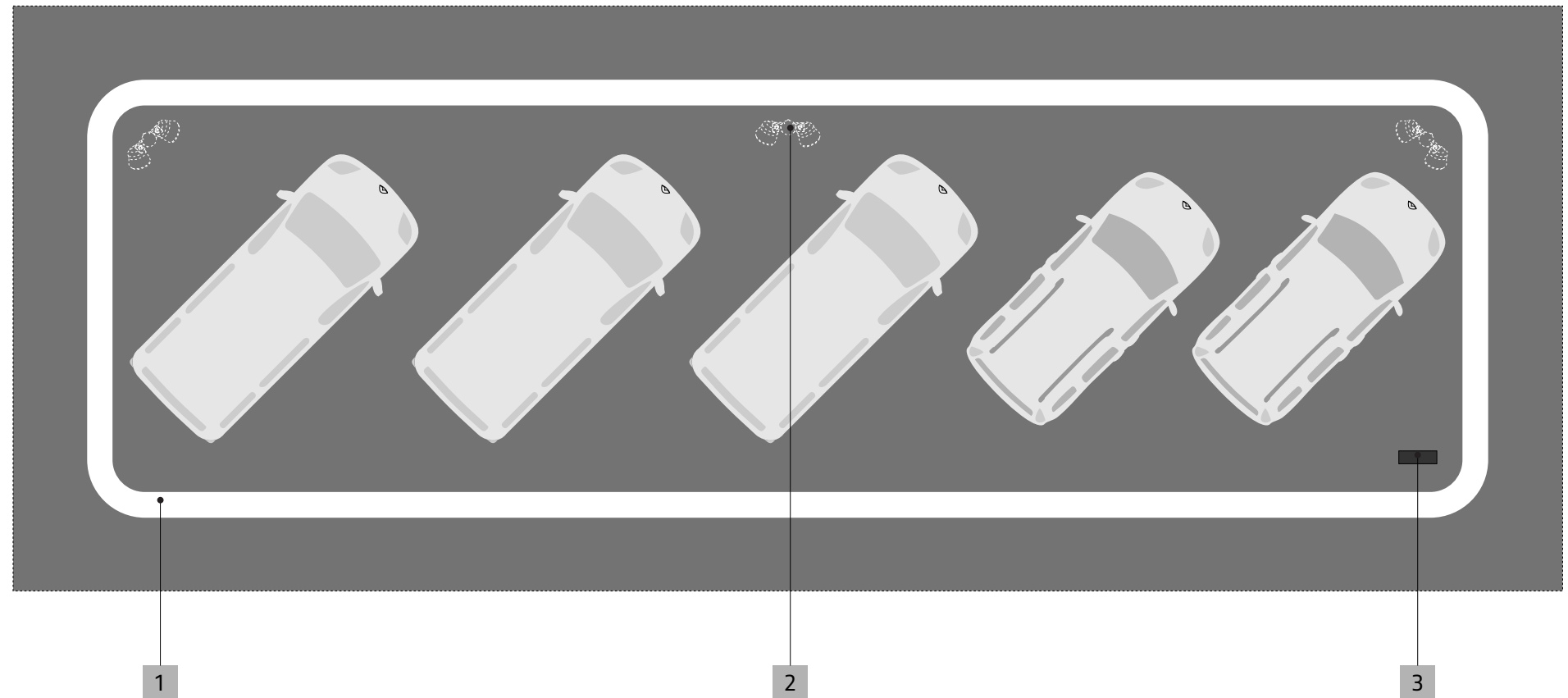

### IMPLEMENTATION PRINCIPLES

**The outdoor display area gives visibility to the Renault Pro+ offer through the impact of the presence of the vehicles exhibited.**

- 1 Ground marking of the area.
- 2 Lighting mast.
- 3 Area mast.

## 9.1.5 Integration of the Renault Pro+ outdoor display area into the general drawing

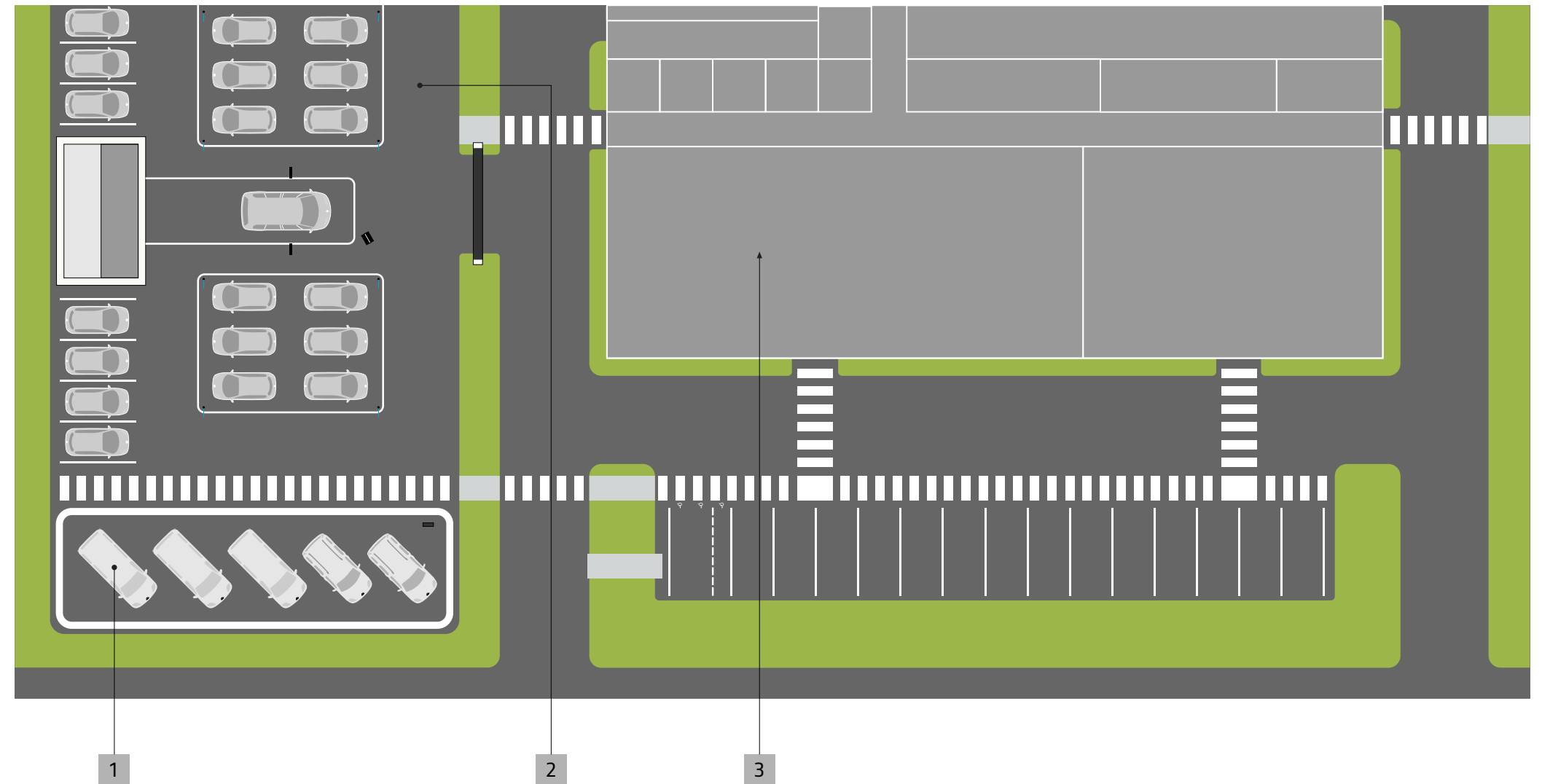

### IMPLEMENTATION PRINCIPLES

**The Renault Pro+ display area is preferably located near the Renault showroom.**

**Pedestrian paths connect it to the customer parking lot and the central building.**

As an option, a Renault Pro+ sales office can be integrated into the building.

1 Renault Pro+ outdoor display area.

2 renewed display area area.

3 Renault showroom.

9.2

RENAULT PRO+ SALES OFFICE

## 9.2.1 Fundamentals

### **Generic principle**

In addition to the outdoor display area, a Renault Pro+ sales office can be integrated into the Renault showroom.

One or more LCVs can be integrated into the Renault showroom provided that the entire Renault range can be presented there (6 to 8 vehicles depending on the available space).

### **Don't**

Large-volume vehicles (Trafic or Master) are never presented in the Renault showroom due to their imposing dimensions.

The specific terms of integrating a Renault Pro+ showroom into a site are described in the dedicated guides to this label.

## 9.2.2 Integration of Renault Pro+ sales office into general drawing

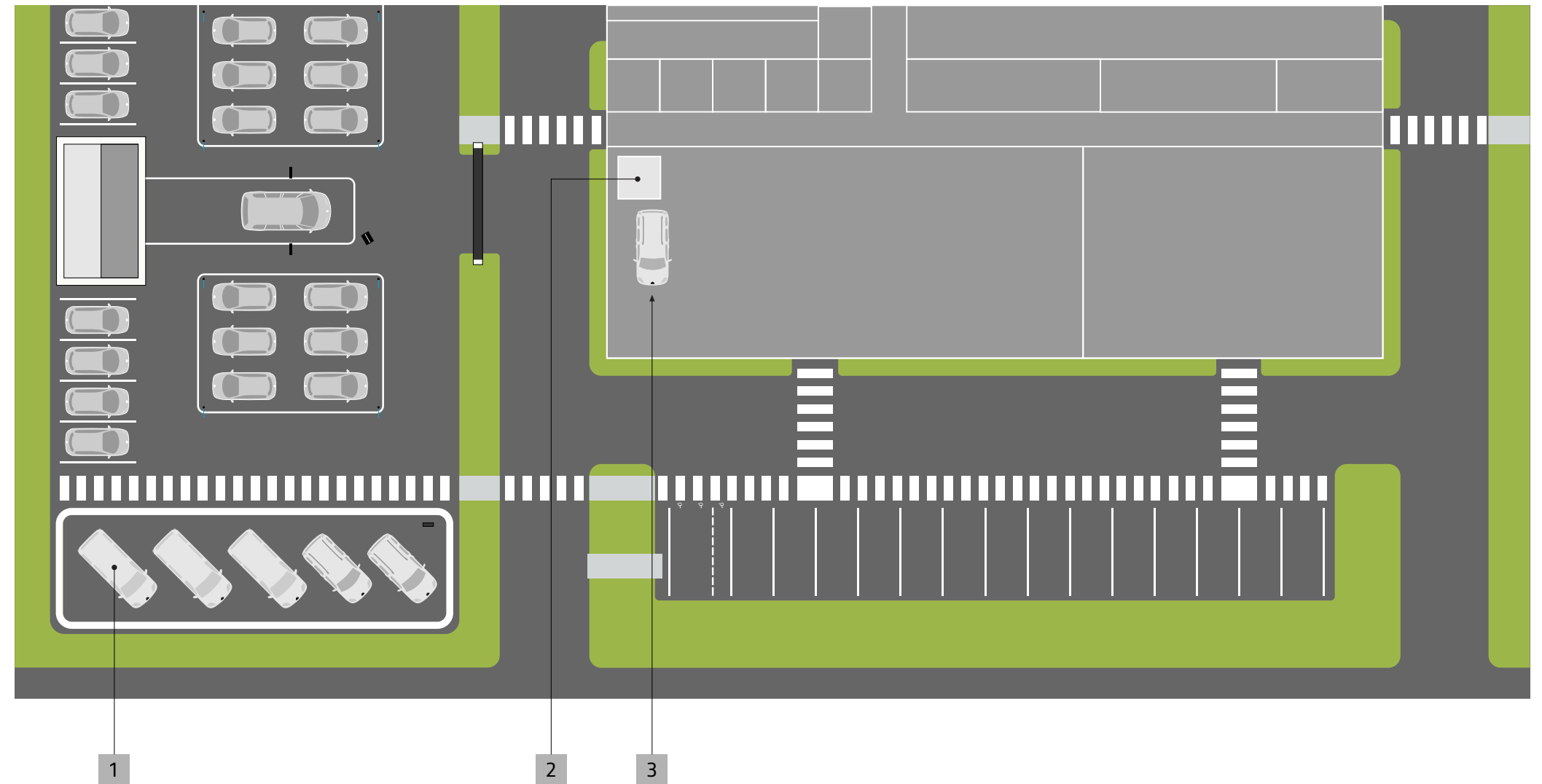

### IMPLEMENTATION PRINCIPLES

**Renault Pro+ sales office can be set up in the Renault showroom.**

**Optionally, one or more small-volume utility vehicles are presented in the showroom near the sales office dedicated to professional customers.**

- 1 Renault Pro+ outdoor display area.
- 2 Renault Pro+ sales office in an island.
- 3 LCVs in the Renault showroom.



## 9.2.3 Integration of an LCV into the Renault showroom

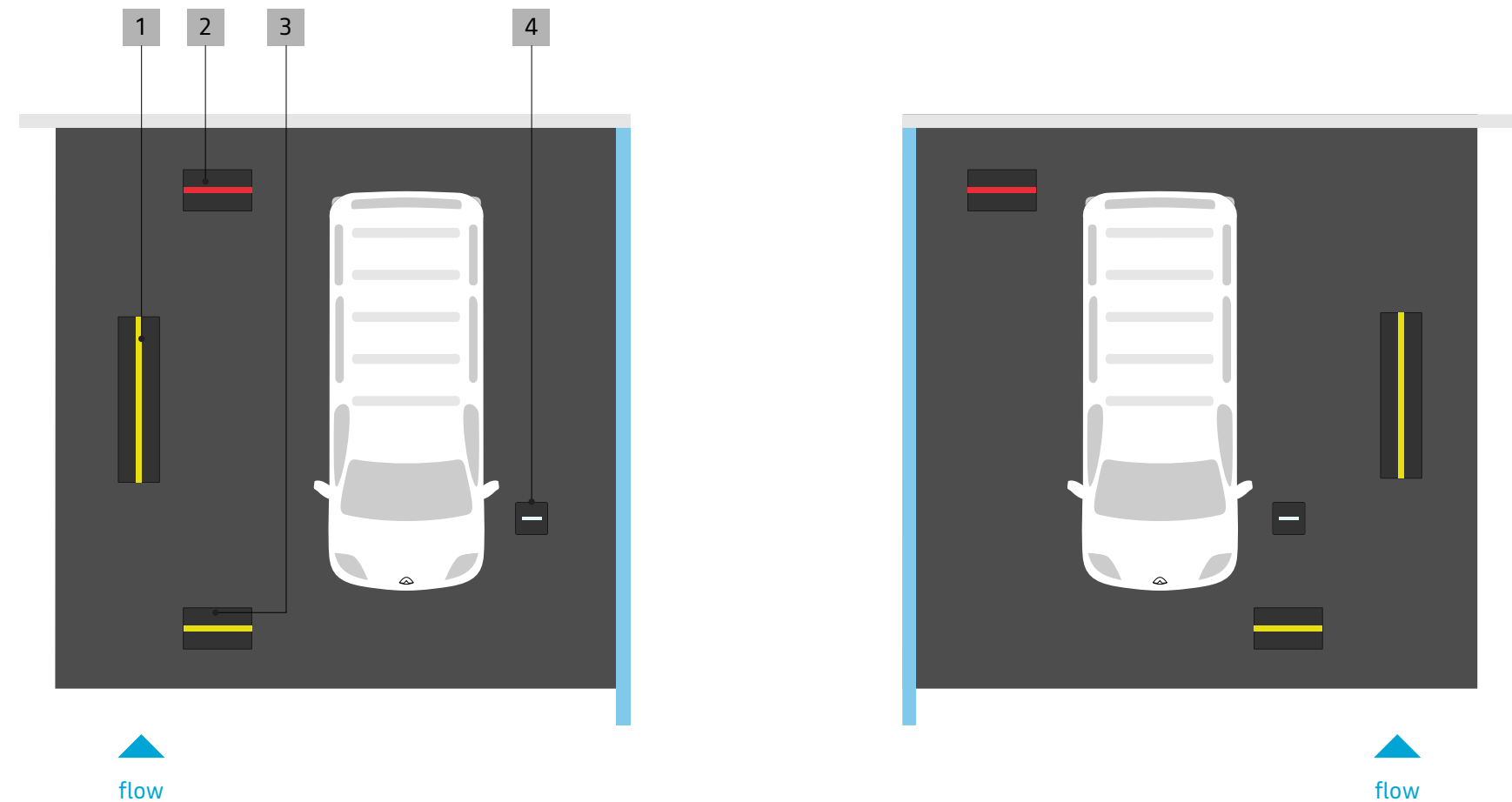

### IMPLEMENTATION PRINCIPLES

Depending on the position in the showroom and the customer flow, the layout of the different components evolves.

The exhibition area can be backed by the back wall of the showroom and preferably in a corner of the showroom.

It is advisable to avoid the presence of a Master and/or a transformed vehicle in new vehicle showrooms.

- 1 2x2 LCV charging POS.
- 2 Product totem-kakemono.
- 3 Price display.
- 4 Customer promise totem-kakemono.

10

BACK-OFFICE AREAS

10.1

ADMINISTRATIVE AREAS

## 10.1.1 Fundamentals

### **Generic principle**

It is recommended to locate administrative offices (not accessible to customers) on a mezzanine above sales offices and shared services in order to optimize the site's floor space and not mix front-office and back-office flows.

## 10.1.2 Presentation

### GENERIC PRINCIPLE

**Administrative areas are treated in a neutral manner (without the presence of brand identity signs).**

**They are offset from the front-office spaces and installed on the mezzanine, accessible via a stairwell connecting them to the common areas.**

- 1 Frames of the administrative offices are painted in black.
- 2 Administrative furniture is that recommended by Renault group. The seat coverings are medium grey.
- 3 Floor (mezzanine and administrative offices) is medium grey close to the colour used for the treatment of the common areas.
- 4 Glazed walls (mezzanine and offices) are made of clear glass.
- 5 The facade facing the showrooms is painted in RAL 7021 grey in matt finish (frame of the glass walls and walls).

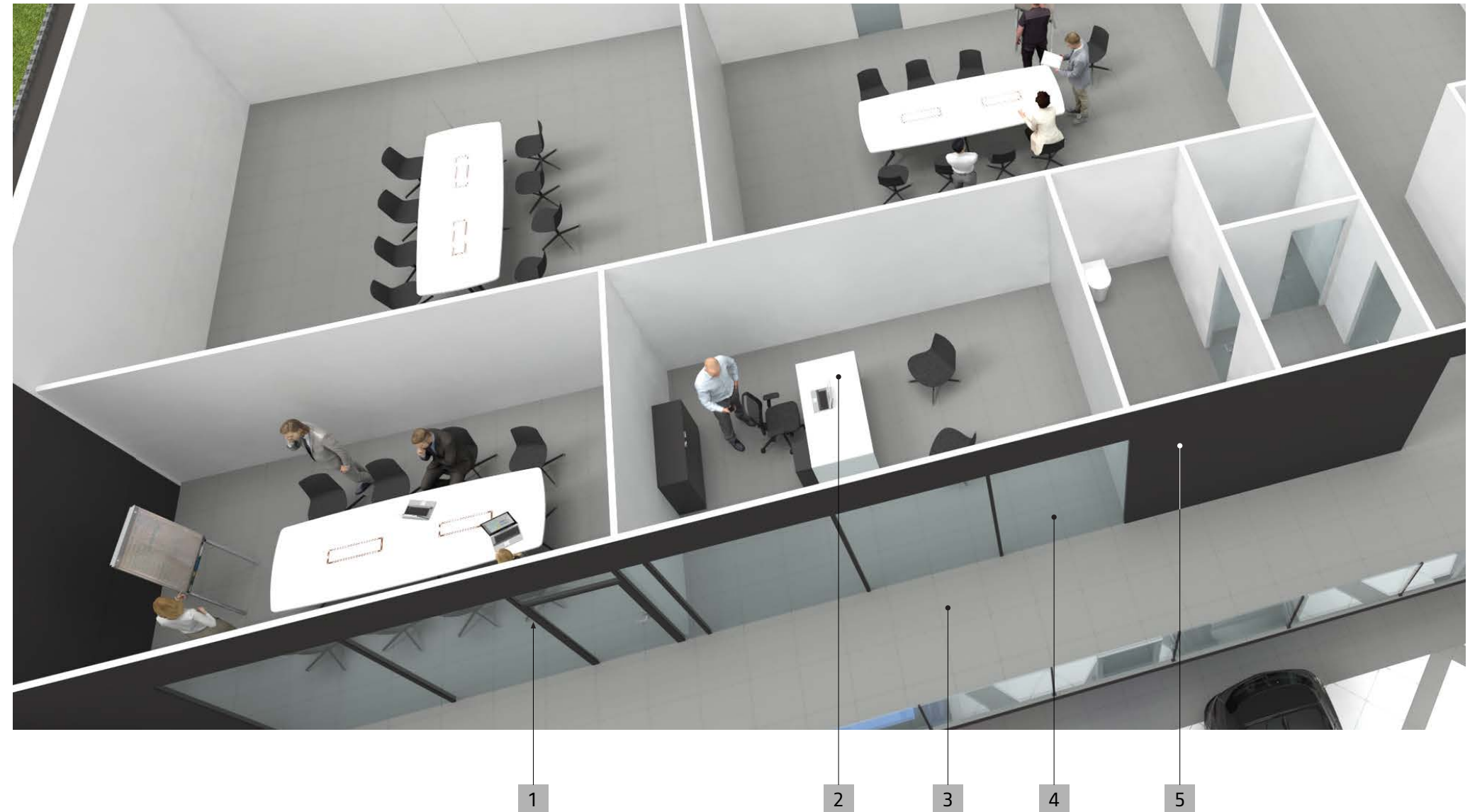

# 10.2

TECHNICAL AREAS

## 10.2.1 Fundamentals

### **Generic principle**

Renault Group standards apply in the back-office technical areas.

The different functions of the workshop are organized according to the different incoming flows (vehicles, spare parts, E-tech Workshop, etc.) and the outgoing flows to the front office (handover area and return parking following maintenance operations).

## 10.2.2 General atmosphere

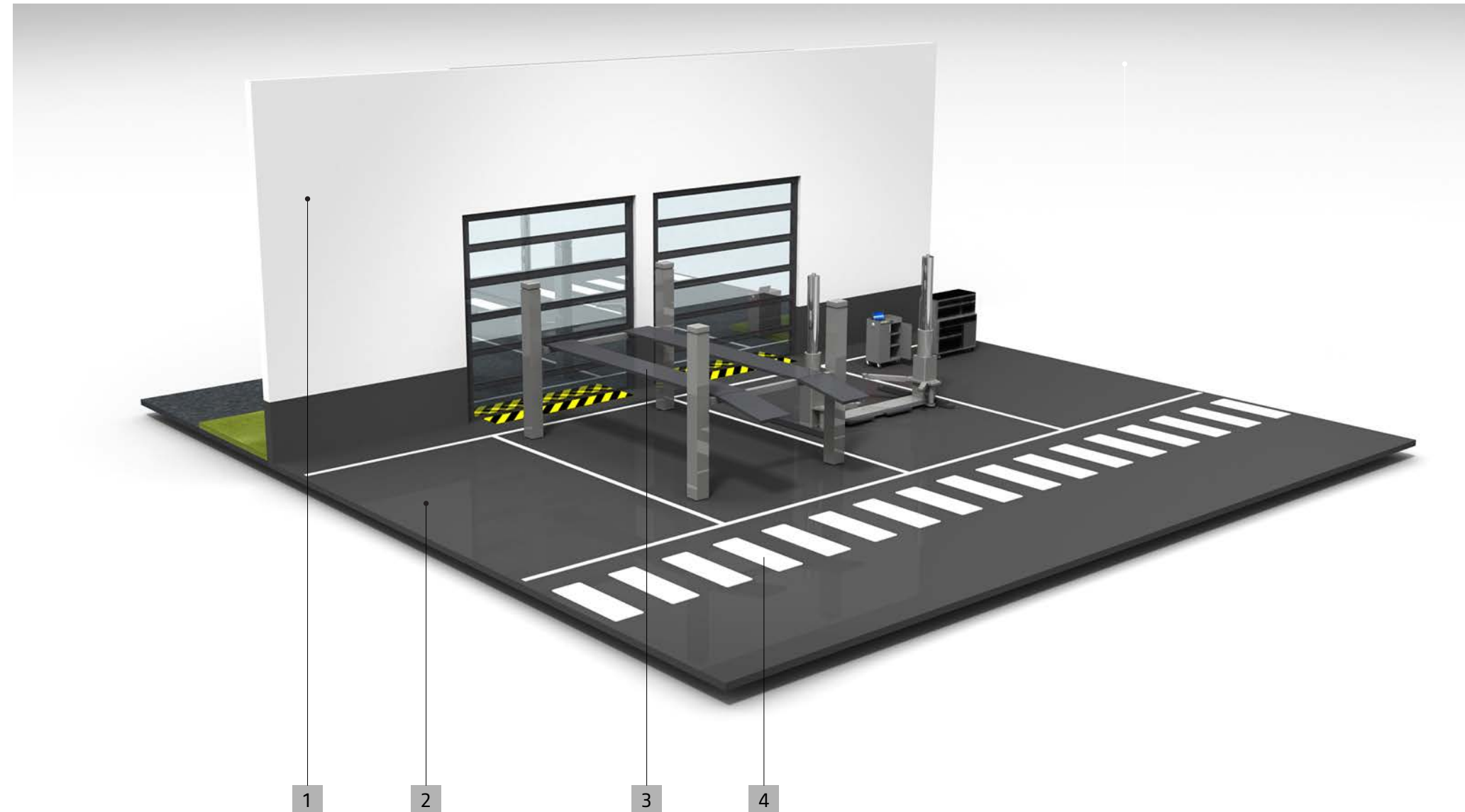

### GENERIC PRINCIPLE

Renault Group back office standards apply to the workshops of the multi-brand sites.

- 1 Walls  
RAL 9010 matt white paint with RAL 7016 dark grey base to a height of 1 m.
- 2 Floors  
Self-levelling mortar with RAL 7043 dark grey epoxy resin or dark grey technical tiles.
- 3 Bridges and lifting equipment  
The workshop equipment is subject to approval, including for the colours chosen: RAL 7016 grey platforms and RAL 9006 metallic grey pillars.
- 4 Floor markings  
Pedestrian paths and workstation boundaries are painted in RAL 9003 matt finish.



### 10.2.3 Layout example

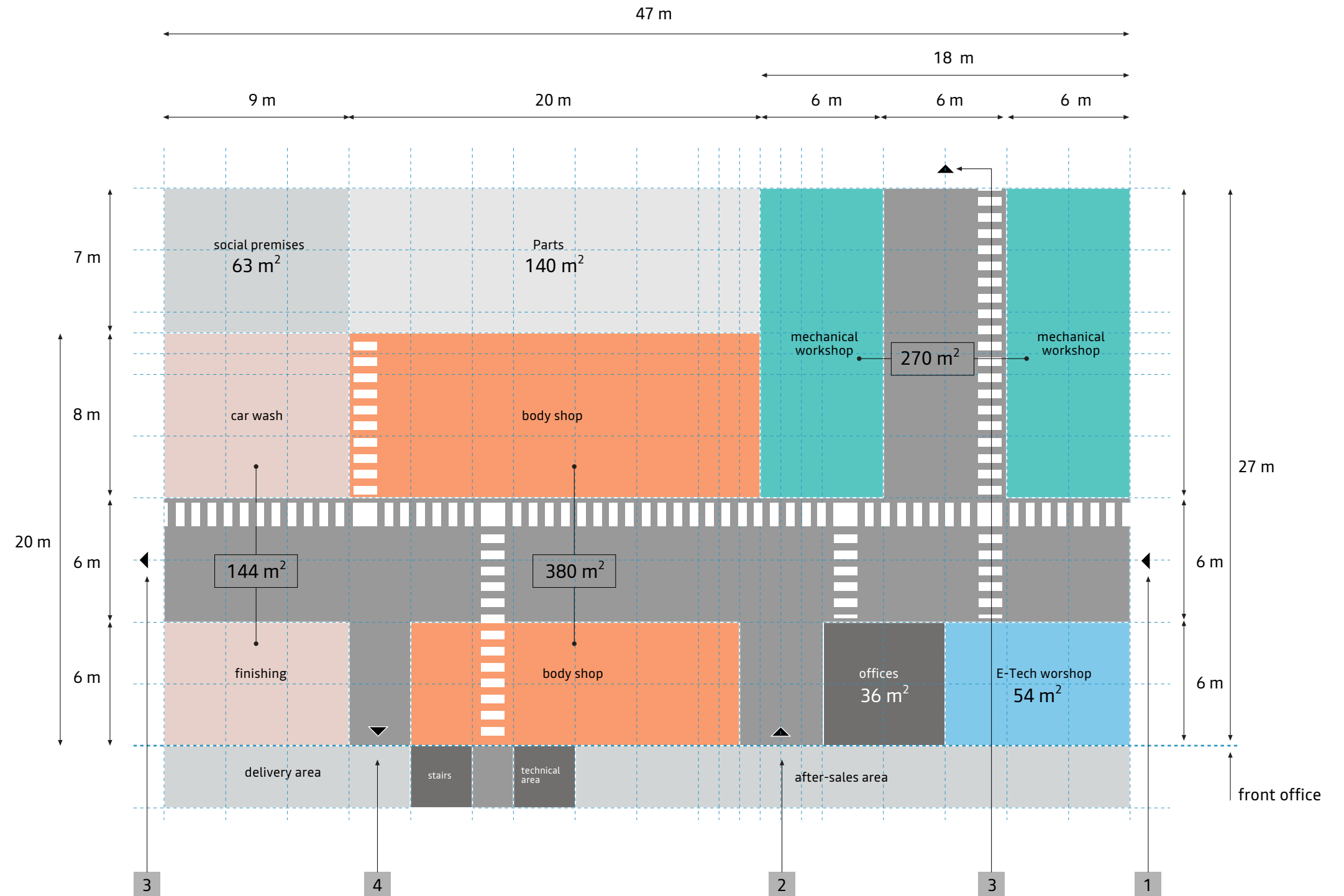

**DESCRIPTION**

The layout opposite is given as an example.  
 Total surface area is around 1000 m<sup>2</sup>.

The different functions take into account the different flows:

- 1 External incoming flow.
- 2 Incoming flow from after-sales area.
- 3 Outgoing flow to the outside.
- 4 Transition from finishing to the handback area.

11

ALPINE MULTI-BRAND SITES

11.1

GENERIC PRINCIPLES OF INTEGRATION

## 11.1.1 Alpine customer journeys

- 1 **Customers have a dedicated parking lot located** in front of the showroom entrance.
- 2 **The Alpine showroom has a dedicated entrance.** It is completely separated from the other areas of the site by a solid opaque partition.
- 3 **Customers are welcomed and wait** in the Alpine showroom.
- 4 **Vehicle configuration, negotiation and financing** are carried out by a dedicated Alpine advisor.
- 5 **Delivery and handover** are done in the Alpine showroom.
- 6 **Customers are welcomed for after-sales operations in the showroom.** Vehicles are returned in front of the Alpine showroom.
- 7 **Alpine certified used vehicles are displayed in the showroom** or nearby.

## 11.1.2 General view of a Renault Dacia Alpine multi-brand site



### 11.1.3 Key elements of integrating an Alpine showroom



A complete identification of the Alpine facade



Dedicated customer parking in front of the Alpine showroom



A independent showroom from other functions of the site



A harmonious facade offering great visibility

# 11.2

SURROUNDINGS AND ALPINE CUSTOMER CAR PARK

## 11.2.1 Fundamentals

### **Identification signage**

Alpine brand can be integrated alongside the Renault and Dacia brands on pre-signage supports.

Totems or flag insignias on masts are specific to each brand.

They are installed in front of the entrance to the respective showrooms.

### **Car parks**

On a Renault Group multi-brand site, customer car parks are dedicated to each brand and located in front of the facades of the respective showrooms.

Common directional signage guides customers, helping to connect the different areas to the brand showrooms.



## 11.2.2 Presignage of Renault Group multi-brand sites

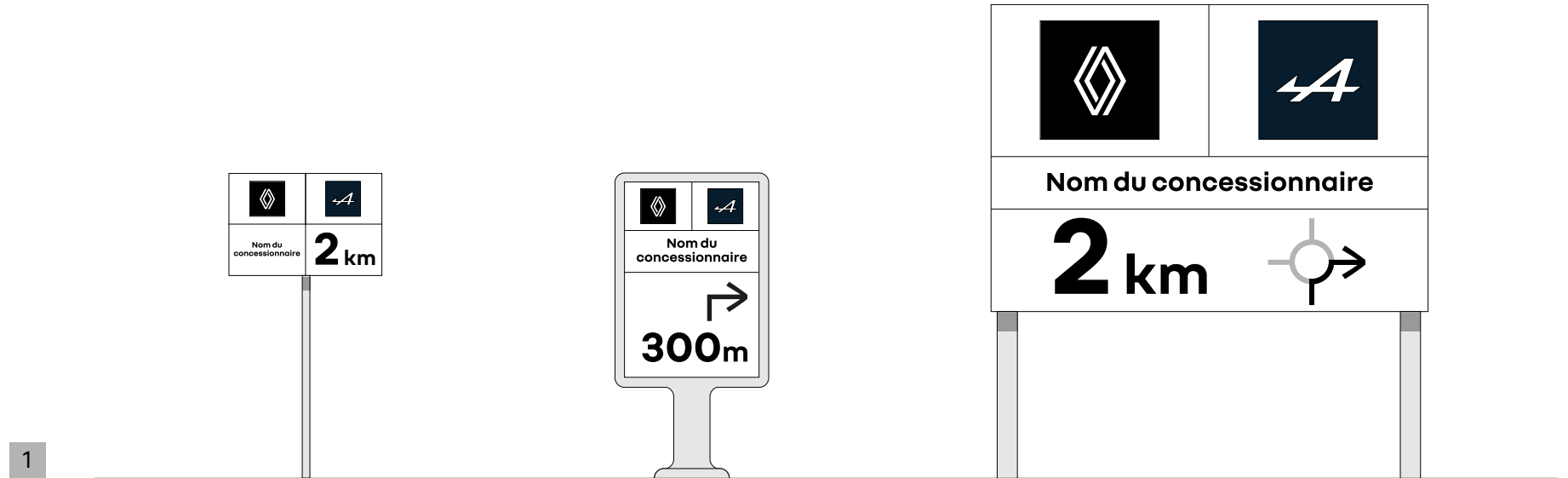

### PRINCIPLES

The pre-signage panels of Renault Group multi-brand sites include the signatures of the different brands presented in a balanced manner.

The directional information is personalized for each situation.

They appear in neutral Renault Group typography.

Different formats are available to meet the implementation cases covered by strict regulations.

1 Multi-brand site with 2 brands

2 Multi-brand site with 3 brands

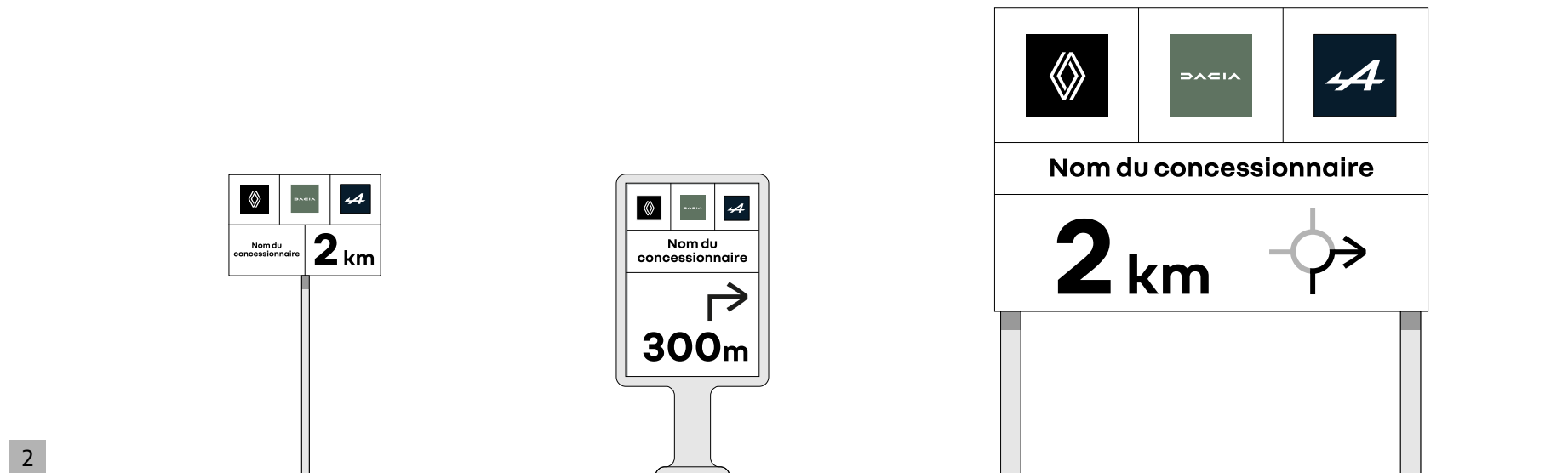

### 11.2.3 Flags of the Renault Group multi-brand sites

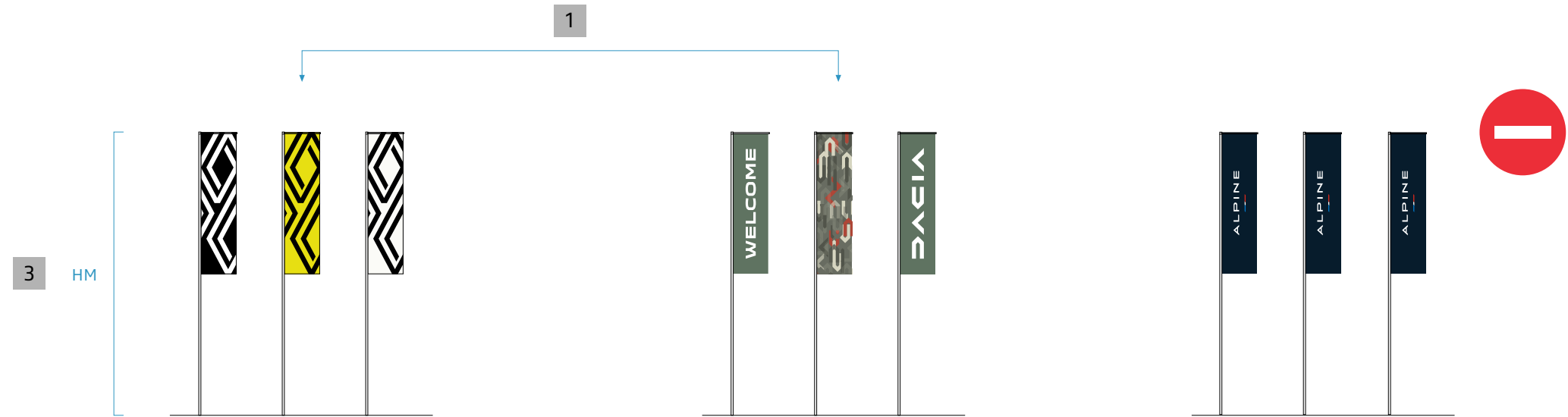

PRINCIPLES

Alpine flags are not part of the brand's current standards.

Only Renault & Dacia brand flags are present on a Renault Group multi-brand site.

- 1 Number of flags is identical for each of the brands present on the site. Flags of each brand are presented in groups of 3 or 5.
- 2 Dimensions of the flags are the same for each of the brands.
- 3 Heights of the masts are the same for each of the brands.

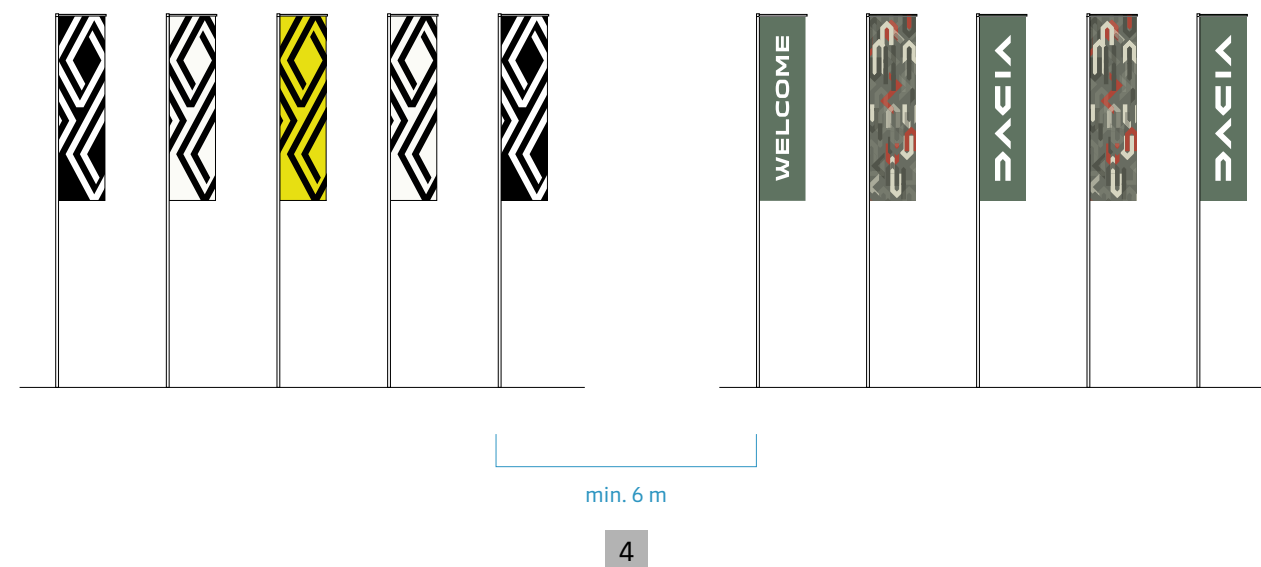

## 11.2.4 Flags • Don't

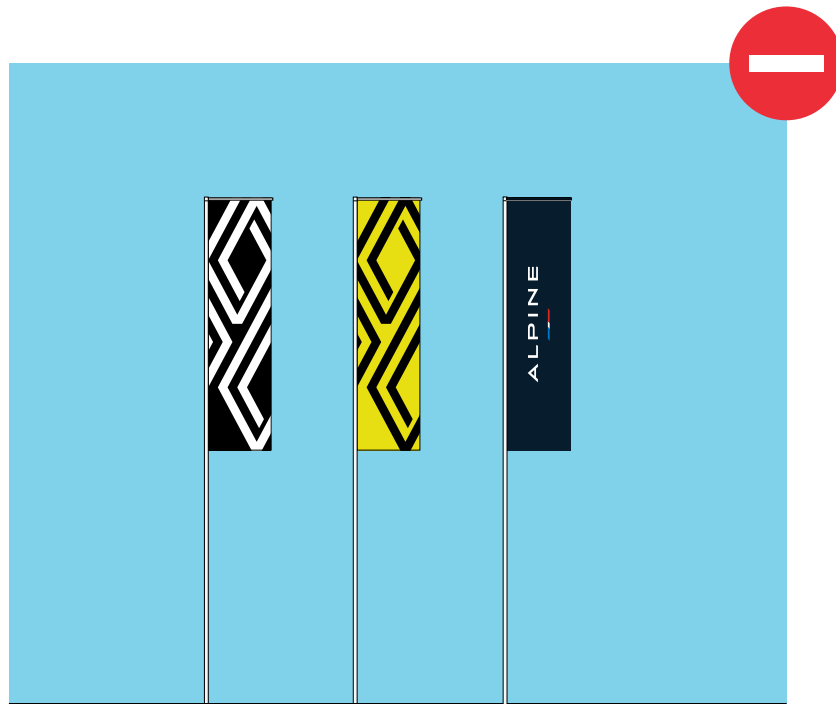

1

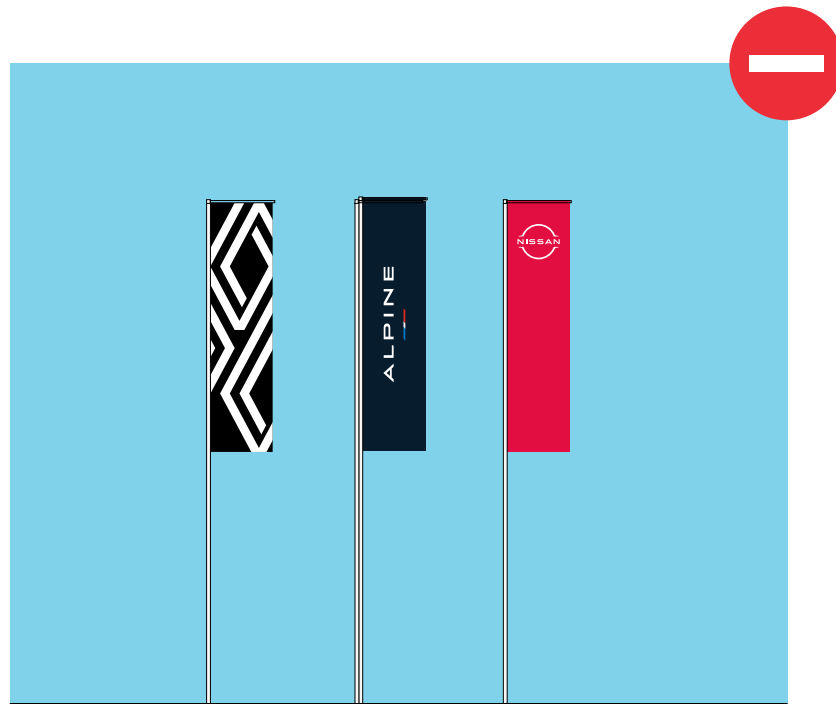

2

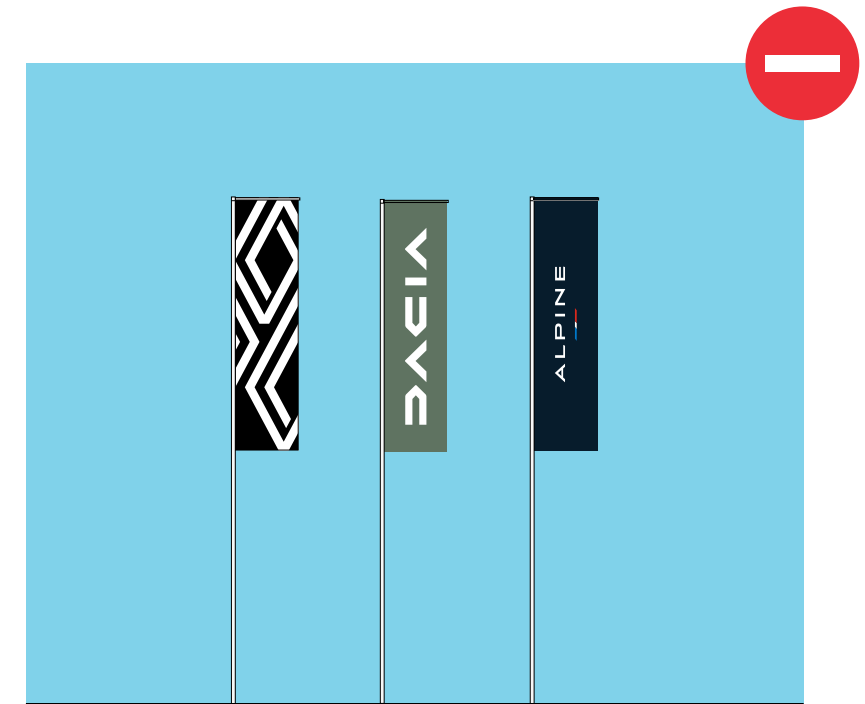

3

### DON'T

- 1 Mix of Renault flags with an Alpine brand flag.
- 2 Mix of Renault Group brand flags with that of a brand outside Renault Group.
- 3 Mix of the flags of the 3 Renault Group brands.

## 11.2.5 Totems

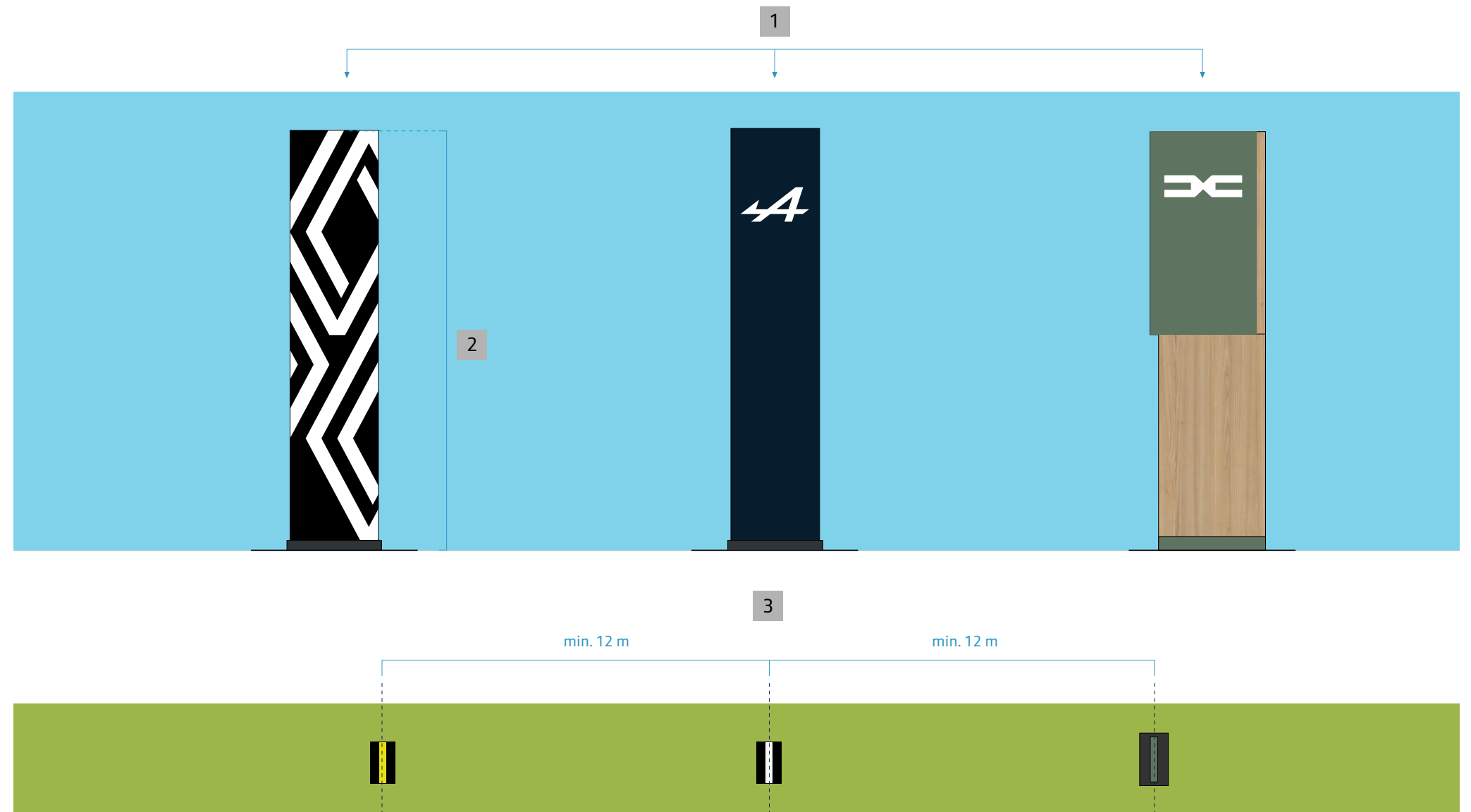

### PRINCIPLES

- 1 Totem of each brand is installed in front of the dedicated showroom.
- 2 Totems of the different brands have a similar size and impact.
- 3 For all brands, the minimum distance to be respected between 2 totems is 12 m.

## 11.2.6 Flag insignias on mast

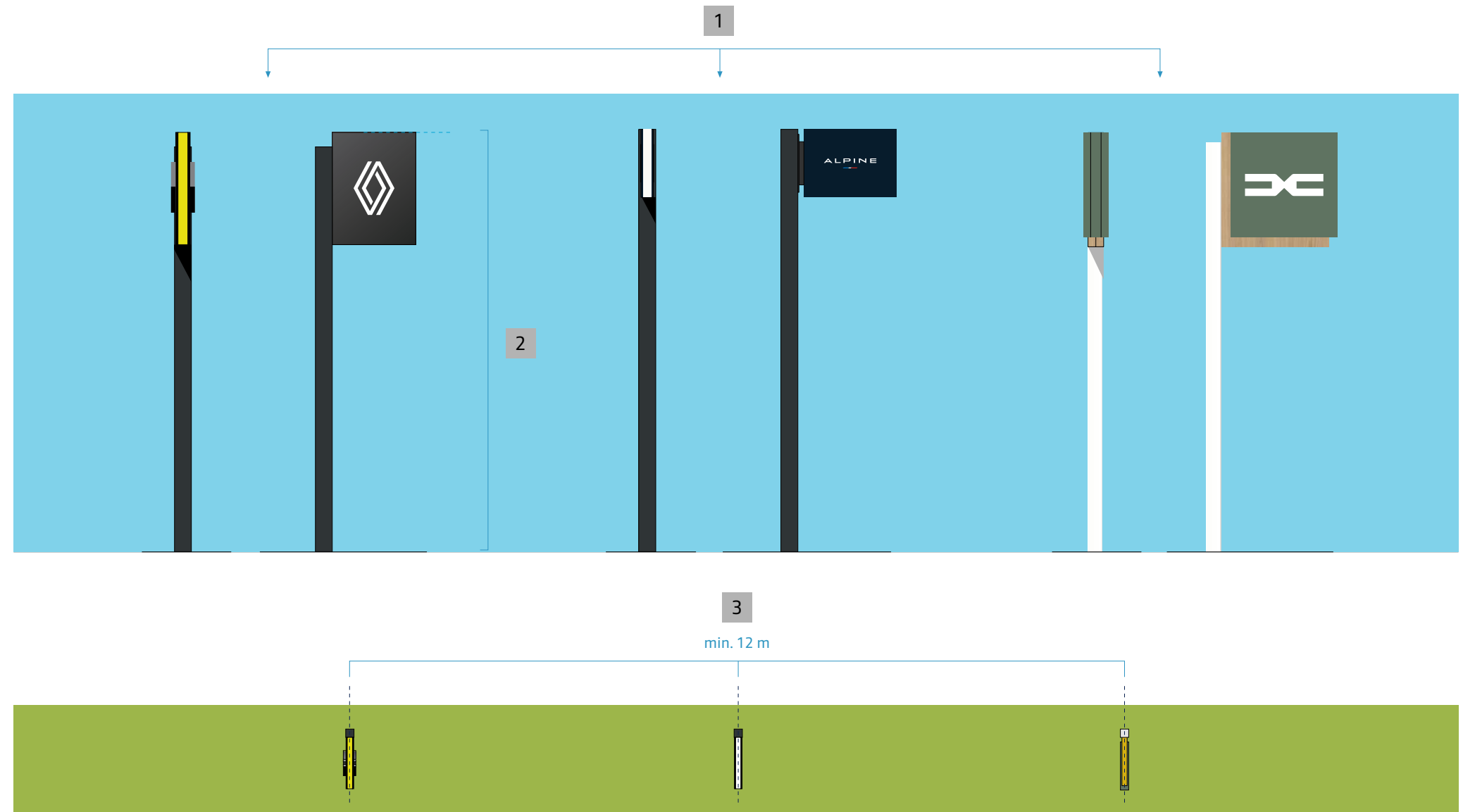

### PRINCIPLES

- 1 Flag insignias on masts are used in peri-urban sites or when totems cannot be installed.
- 2 Flag insignias must be the same size (4.5 or 6.5 m masts), the signs must have a similar impact.
- 3 Minimum distance between 2 signs on masts is 12 m.

## 11.2.7 Flag insignias on facade

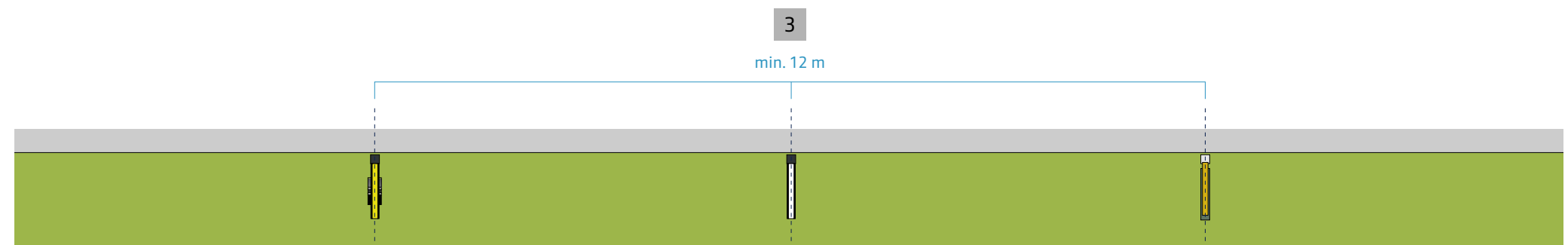
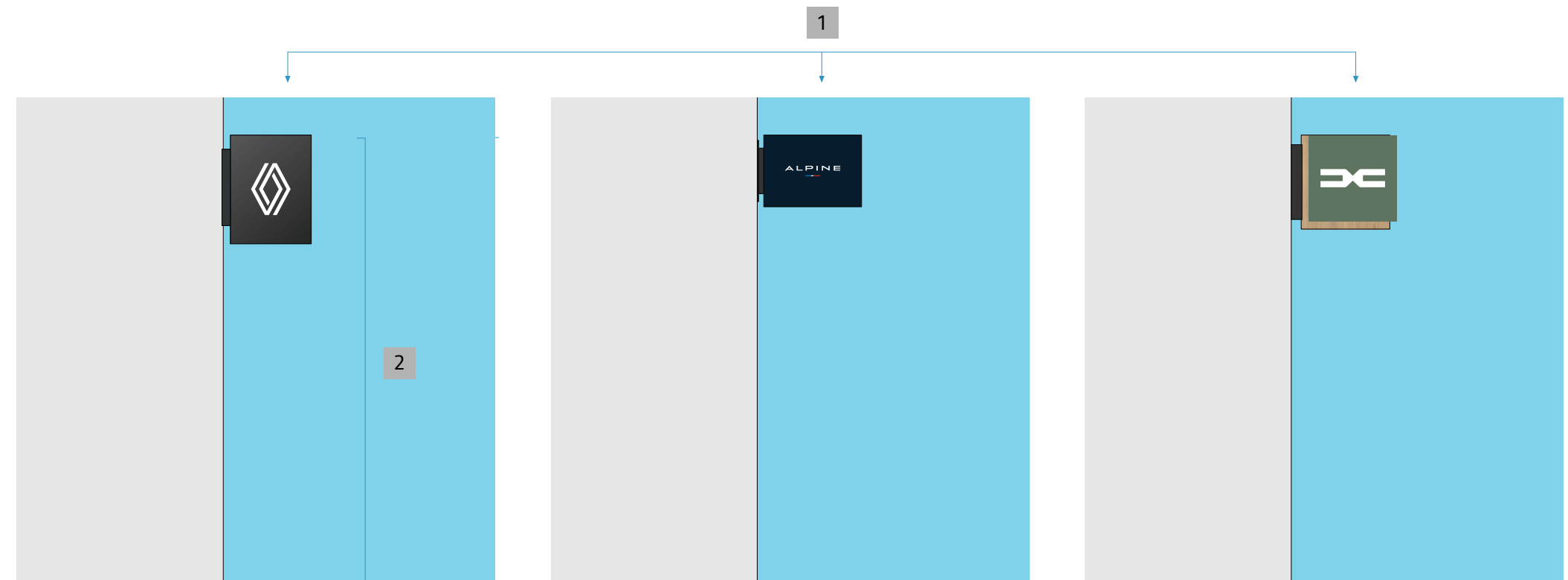

### PRINCIPLES

- 1 Flag insignias on facade are used in urban sites when they cannot be installed on masts, offset from the facade.
- 2 Insignias must be installed at the same height from the ground in order to provide a similar impact.
- 3 Minimum distance between 2 flag insignias is 12 m.

## 11.2.8 Totems et flag insignias • Don't

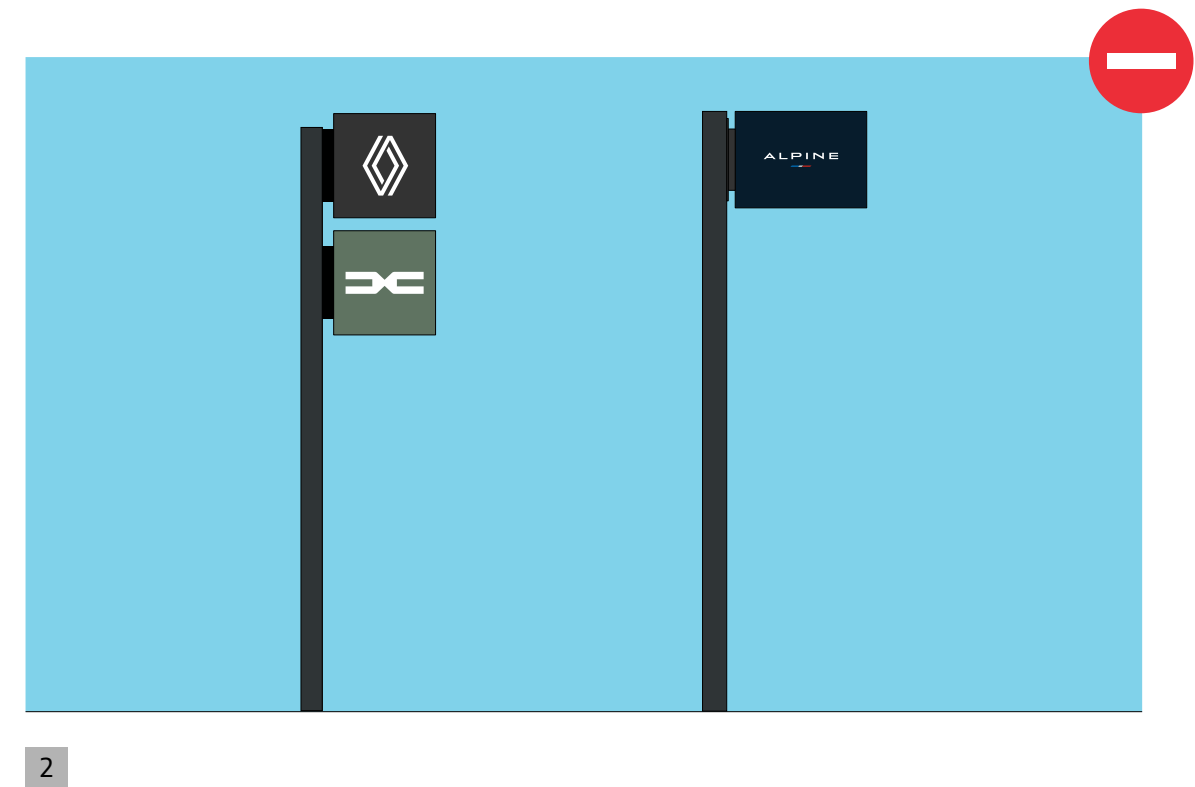

### DON'T

- 1 Flag insignias on masts must not be used in combination with the totem of one of the brands.
- 2 Multi-brand insignias mounted on masts are reserved for the R2 commercial network.

## 11.2.9 Alpine car park & test drive area

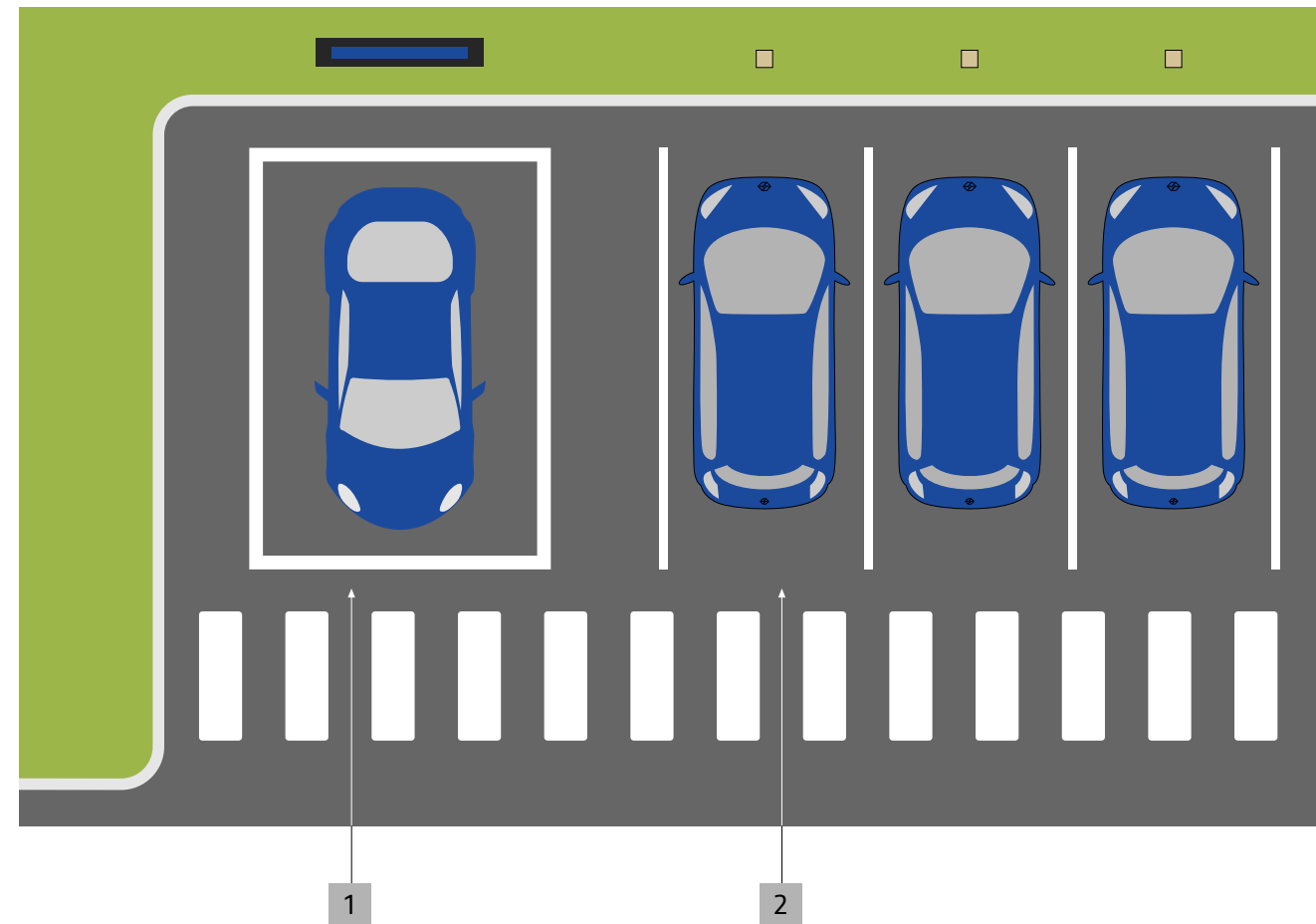

### PRINCIPLE

Alpine customer car park and the test drive area are separate from the other parking lots on the multi-brand site.

- 1 The Alpine test drive area presents a vehicle. It is marked on the ground by a white rectangle.
- 2 A minimum number of 3 parking spaces are dedicated to Alpine customers, located in front of the entrance to the brand's showroom.



## 11.2.10 Alpine car parks • Don't

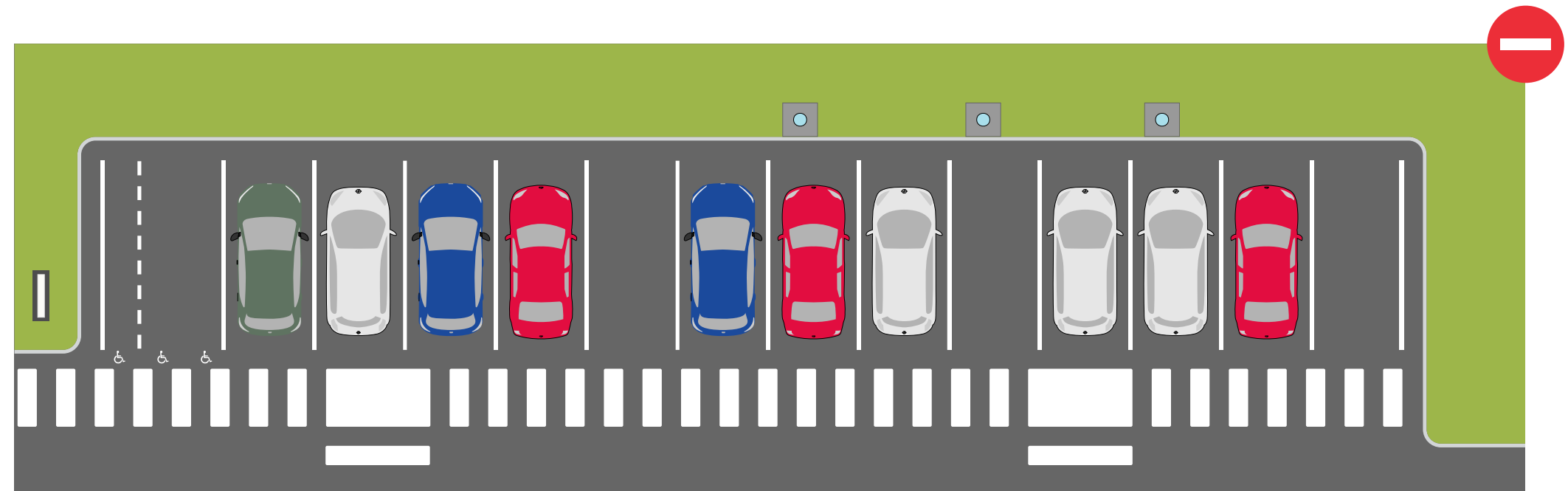

DON'T

**A dedicated car park for Alpine customers is mandatory.**

Under no circumstances should Alpine customers park in a parking lot shared between the different brands.



## 11.2.12 Directional signage

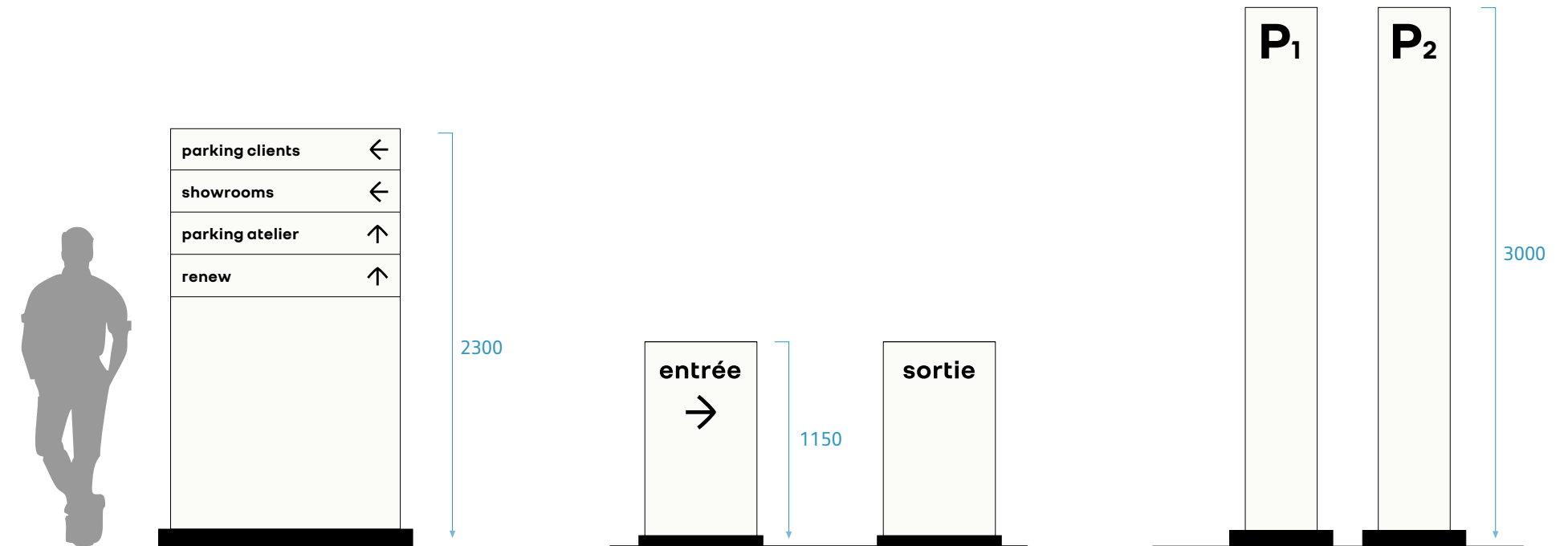

### GENERIC RULE

Multi-brand directional signage must be used.

**No mention of brands (brand name or logotype) must appear on these elements with the exception of the names renew and Renault Pro+.**

## 11.2.13 Directional signage • Don't

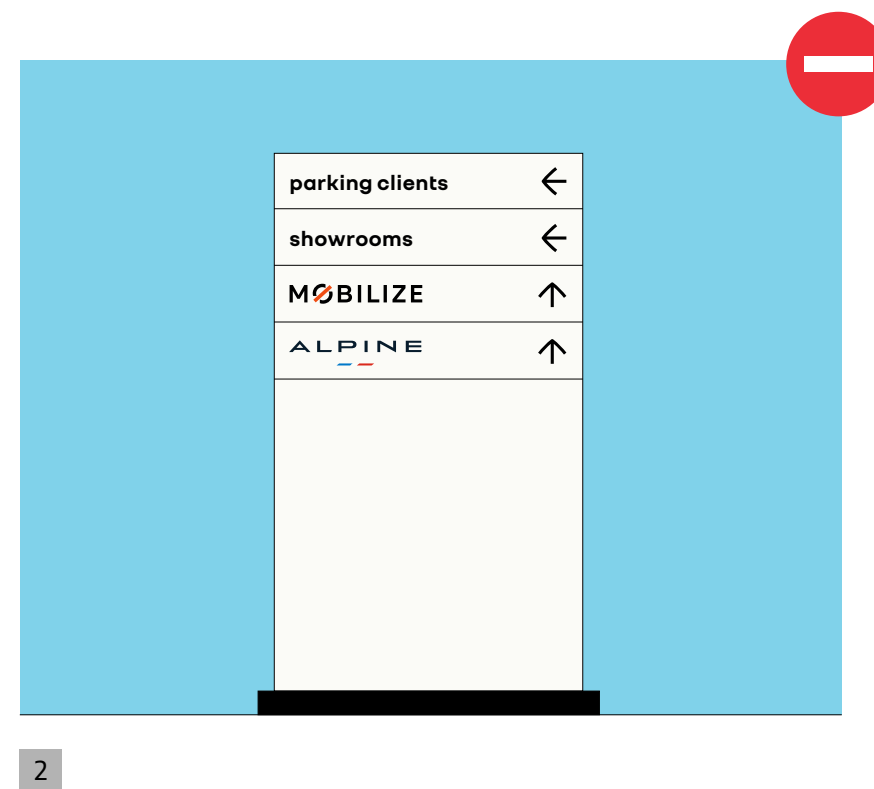
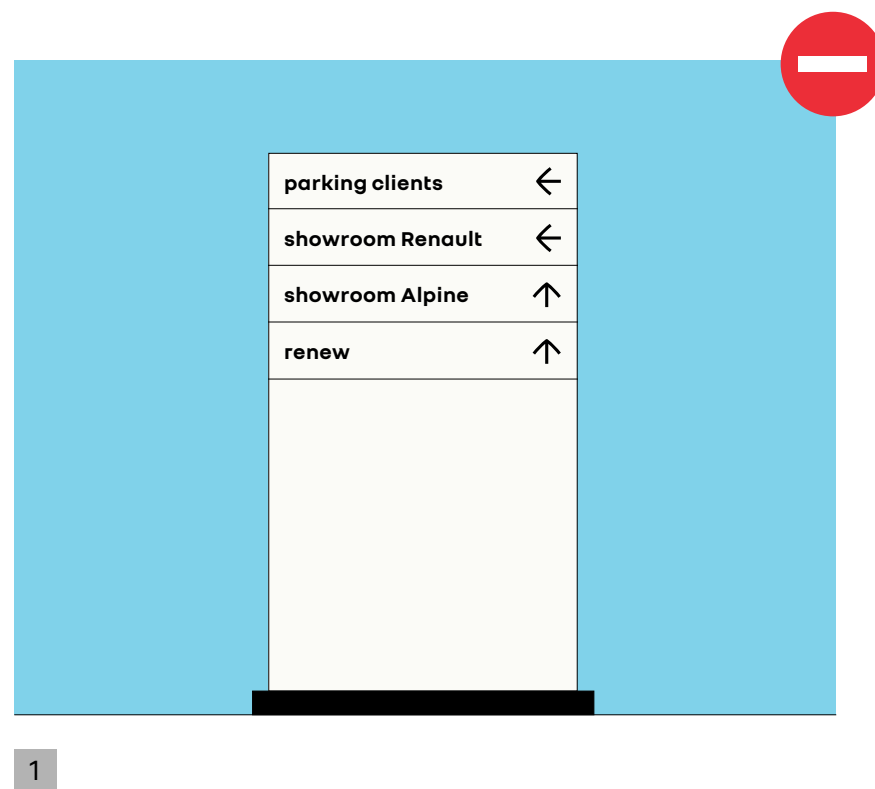

### DON'T

- 1 Use of brand names in titles is prohibited.
- 2 Use of visual identities of brands is prohibited.

# 11.3

SHOWROOMS IMPLEMENTATION

## 11.3.1 Fundamentals

### **Generic rule**

The Alpine showroom is independent of the other functions of the multi-brand site.

### **Don't**

The implementation of a new Alpine showroom in a multi-brand site cannot be done by reducing the minimum exhibition areas allocated to the Renault & Dacia brands (respectively 8 Renault vehicles and 5 Dacia vehicles).

## 11.3.2 Integration of Alpine showrooms into a multi-brand site

### REQUIRED CONDITIONS

- **Visibility of the side facade and therefore of the Alpine showroom.**
- **Total separation (internal and external) of back-office activities.**
- **Direct lateral access for Alpine customers to the dedicated parking lot.**

### PRINCIPLES OF INTEGRATION

- A The Alpine showroom is located on the left side facade.
- B The Alpine showroom is located on the right side facade.

- 1 Renault showroom
- 2 Dacia showroom
- 3 Alpine showroom
- 4 Delivery area
- 5 Back-office workshop
- 6 Common areas
- 7 After-sales area

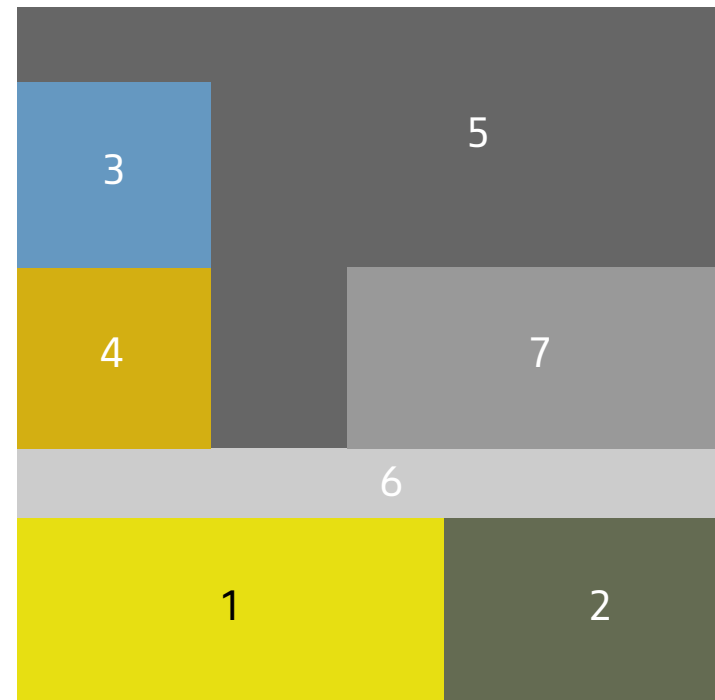

A

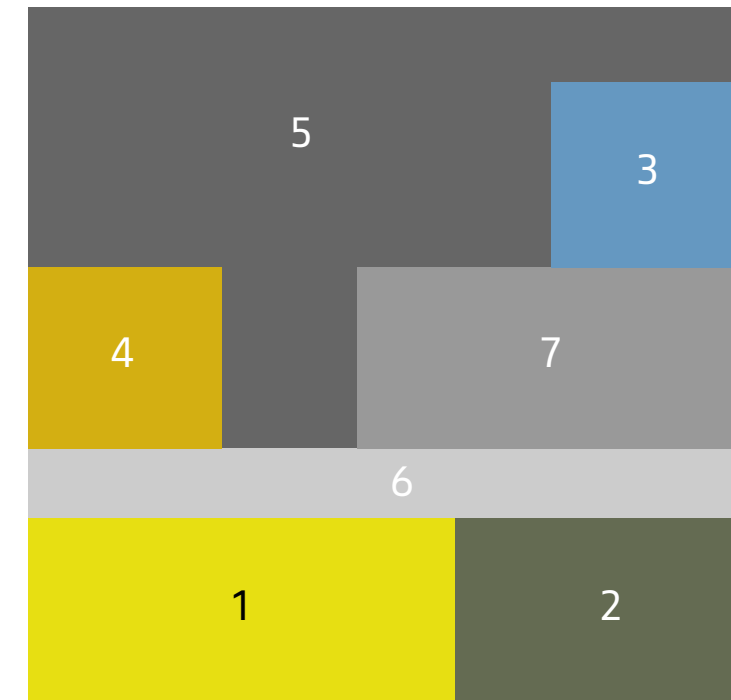

B

### 11.3.3 Possible alternative with change of site organization

PRINCIPLES

A The Alpine showroom is located on the side façade and meets the necessary conditions of visibility and separation from the back office.

B Access to the after-sales area is on the main façade.

- 1 Renault showroom
- 2 Dacia showroom
- 3 Alpine showroom
- 4 Delivery area
- 5 Back-office workshop
- 6 Common areas
- 7 After-sales area

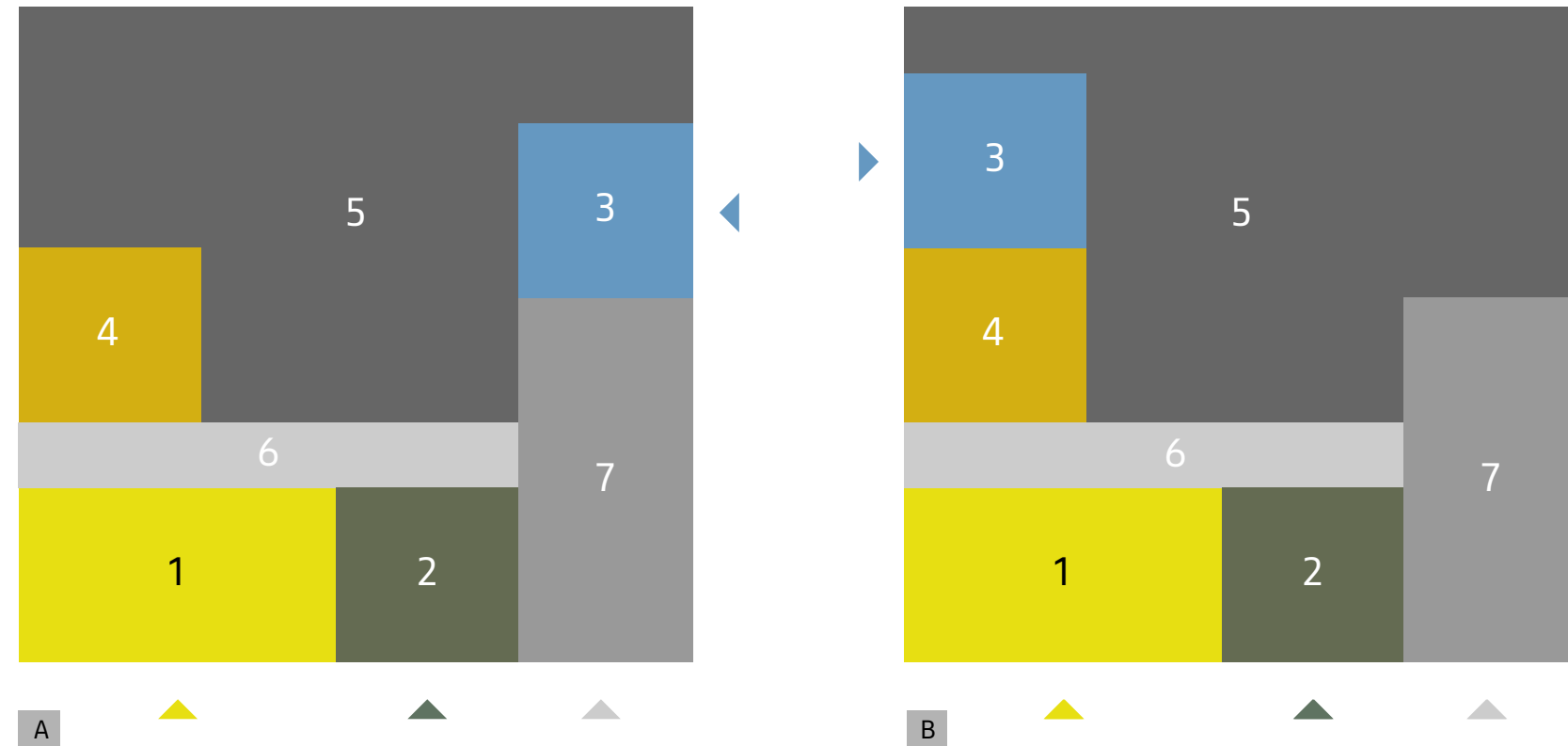



### 11.3.4 Integration of Alpine showrooms • Special case

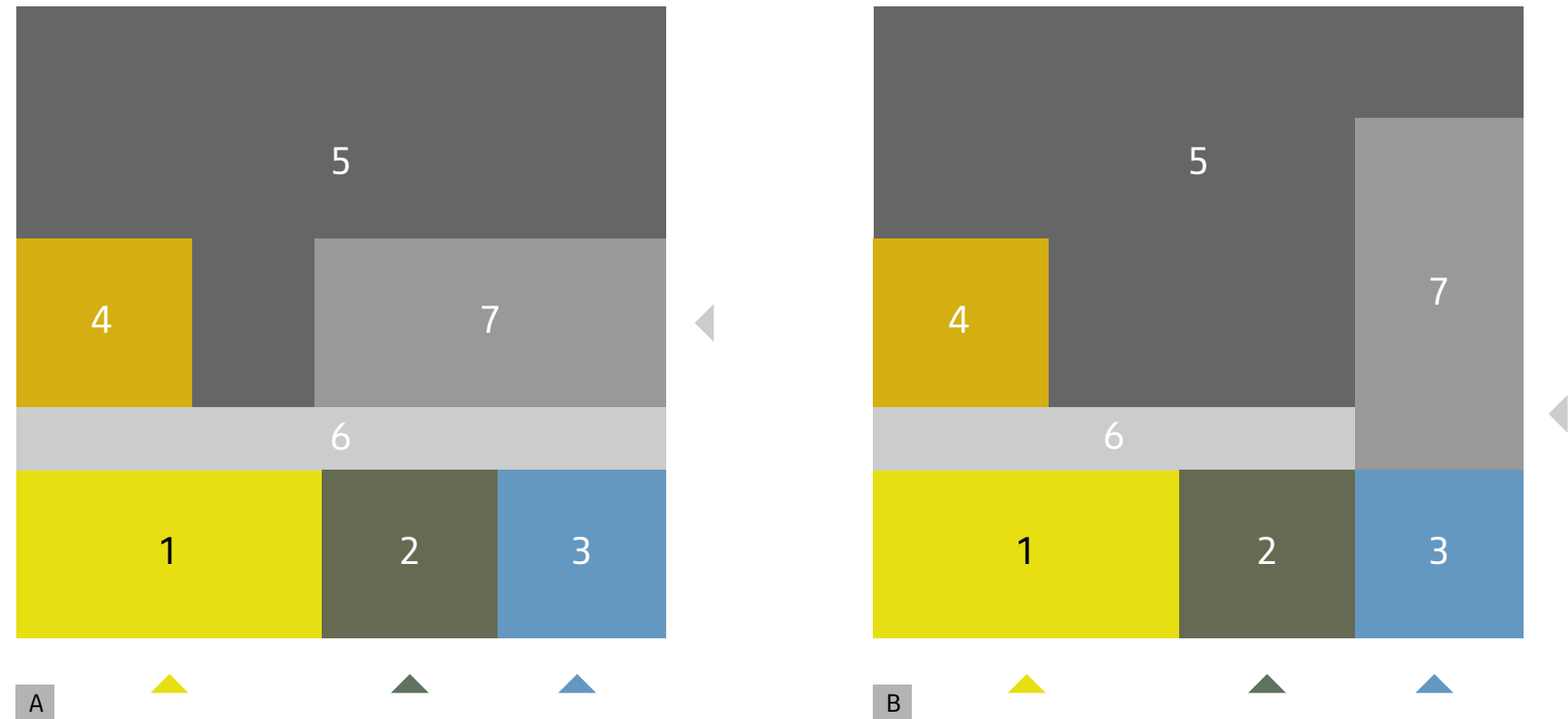

**SPECIAL CASES**

Provided that the minimum surface areas of the Renault & Dacia brand showrooms are respected, allowing for the presentation of 8 and 5 vehicles respectively, the Alpine showroom can be set up in continuity with the other showrooms.

- A Layout on the main facade respecting the general organisation of a Renault Dacia multi-brand site.
- B Layout on the main facade with a change in the internal organisation involving the functional links between common areas.

### 11.3.5 Alpine showroom separation principle

**PRINCIPLES**

The Alpine showroom is separated from the other functions of the site by solid partitions covering the entire periphery of the showroom.

**Please note that vehicle deliveries and customer reception for after-sales service are carried out in the showroom.**

An opaque door allows Alpine staff to access the other functions of the site (not used by customers).

- A Installation at the corner of the facade.
- B Installation in the middle of the facade.

- 1 Full-height solid partition.
- 2 Glazed facade with the dedicated entrance to the showroom.
- 3 Back-office access door.

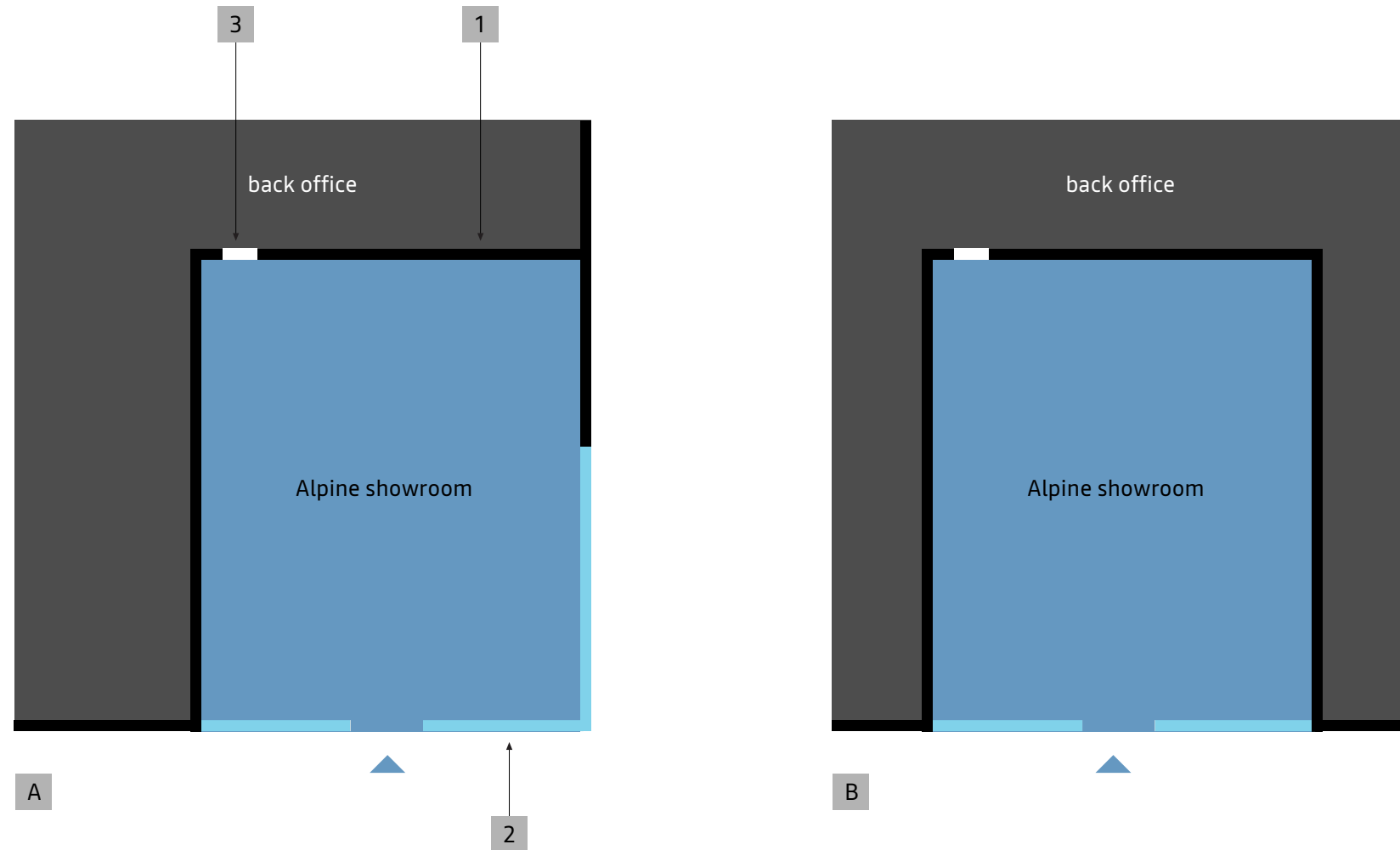

11.4

SHOWROOM FACADES

## 11.4.1 Fundamentals

### **Generic rule**

Showroom facades Alpine are identified by the full application of the brand's signage elements.

Access to the showroom is via a dedicated entrance door.

A minimum distance of 1 m must be respected between the facades of the showrooms.

### **Don't**

The Alpine showroom must never be directly juxtaposed with other showrooms on the site.

## 11.4.2 Rule for the separation of architectural elements

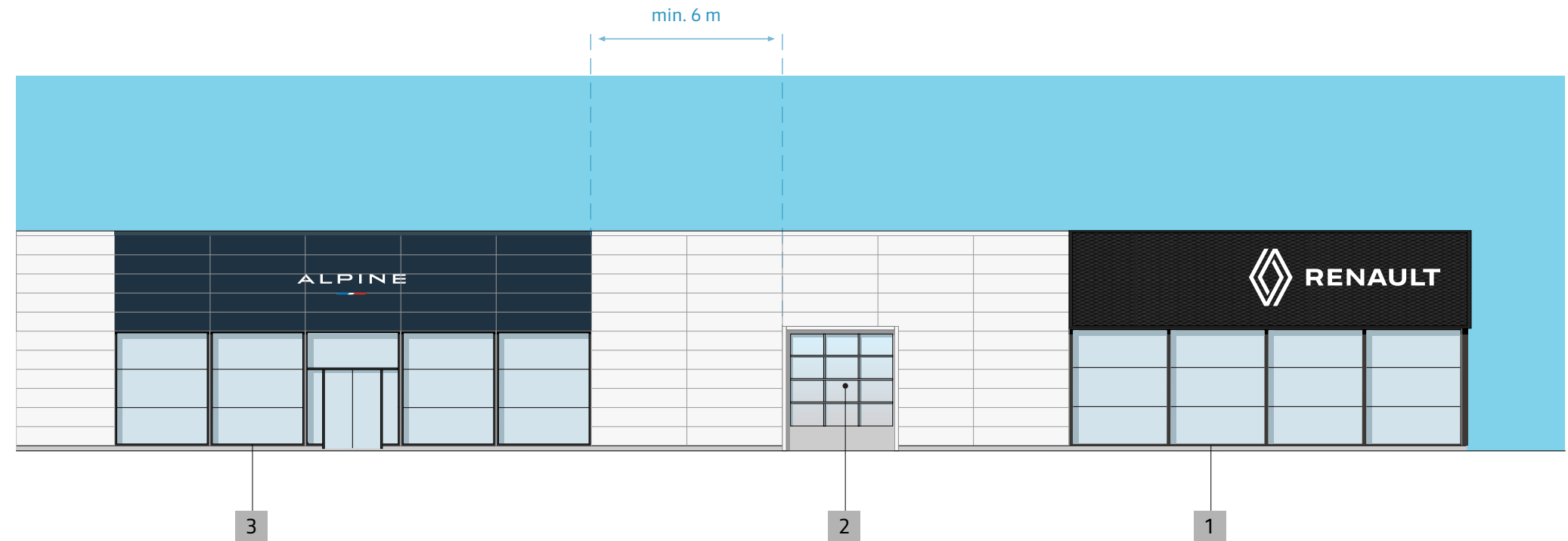

### GENERIC RULE

**A minimum distance of 6 m must be respected between any architectural element and the edge of the Alpine showroom window.**

- 1 Renault showroom.
- 2 Alpine showroom.
- 3 Architectural element (lifting door).

### 11.4.3 Rule of separation of facades from other showrooms

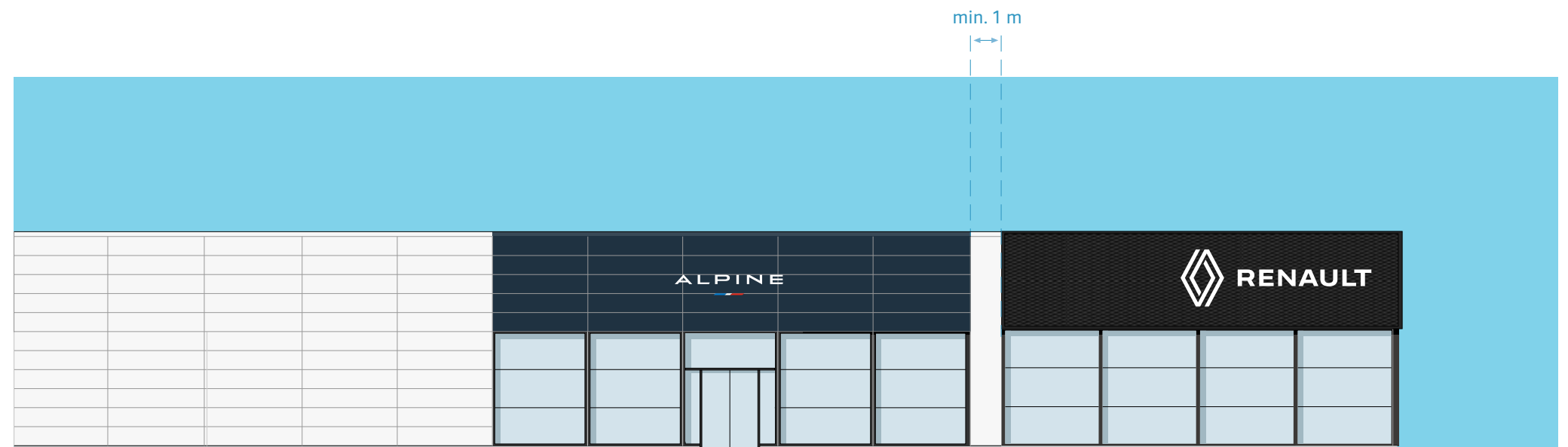

**GENERIC RULE**

**Ideally, a minimum distance of 3 m must be respected between any architectural element and the edge of the Alpine showroom window.**

**With exemption, this distance can be reduced but must never be less than 1 m.**

- 1 Ideal separation between 2 showroom facades.
- 2 Minimum separation between 2 showroom facades.

## 11.4.4 Special case • Malls

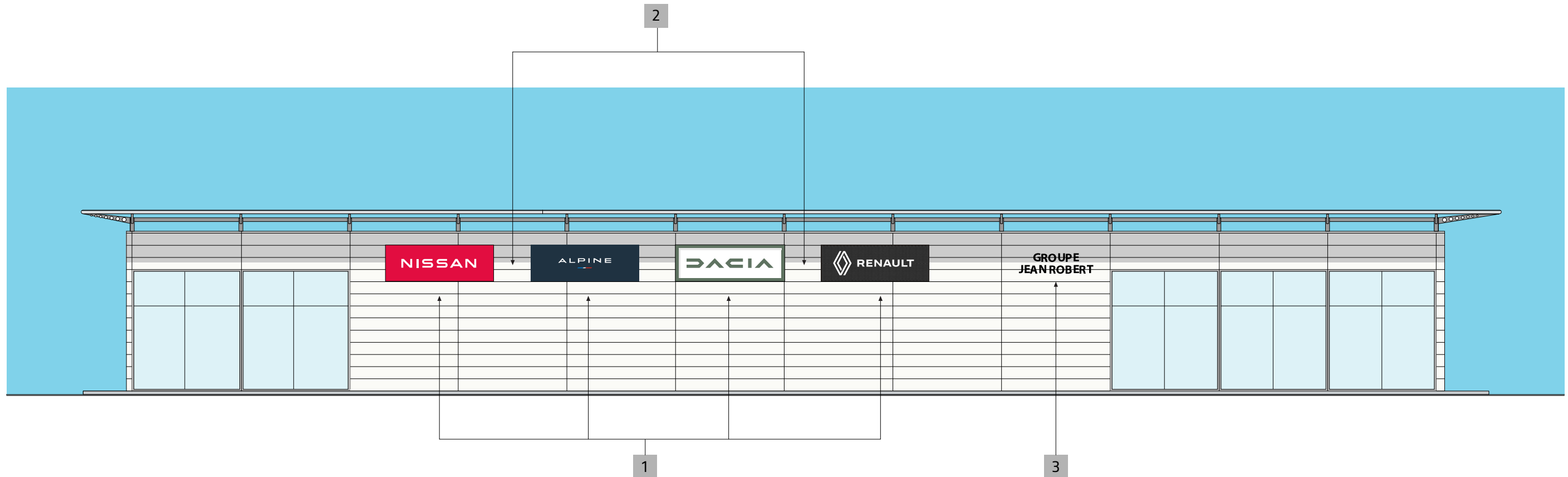

### PRINCIPLES

When the signage cannot be installed above the showroom of each brand; it is recommended to group the signatures on the same facade.

- 1 The signatures offer a similar impact creating a harmonious facade thanks to a common height.
- 2 The installation distance between each signature is identical.
- 3 The dealername is common, clearly separated from the signatures of the brands.

## 11.4.5 Special case • Blind facades

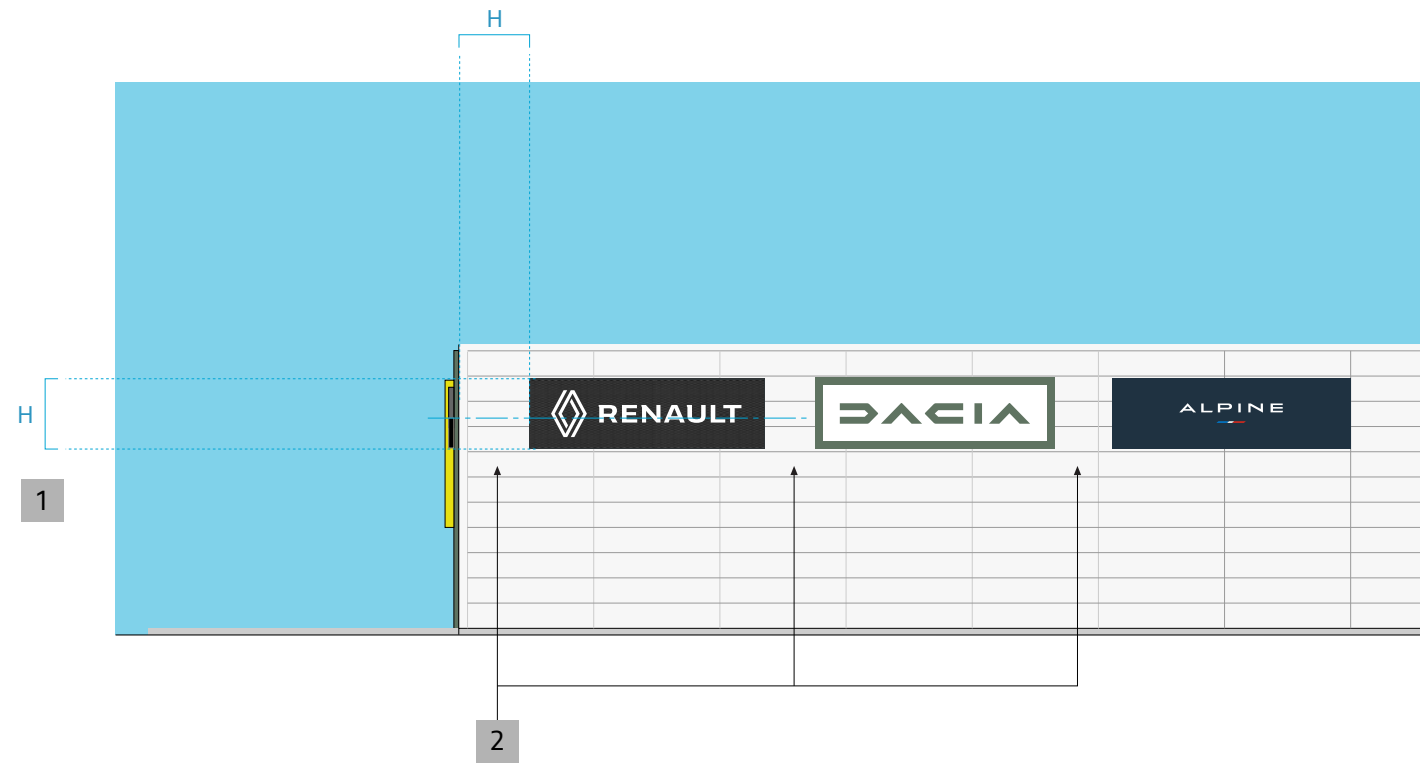

### PRINCIPLES

- 1 Signatures provide a similar impact creating a harmonious facade thanks to a common height.
- 2 The implantation distance between each signature is identical.
- 3 **Emblems alone must not be used on secondary facades in place of brand signatures.**



11.5

AFTER-SALES SERVICE

## 11.5.1 Fundamentals

### **Generic rule**

The reception of Alpine after-sales customers is done in the Alpine showroom by the Alpine advisor.

The return of the vehicle to the Alpine customer is done in front of the showroom.

### **Don't**

Any sign of Alpine brand identity is to be prohibited in the after-sales areas or on the facades.

## 11.5.2 Service reception

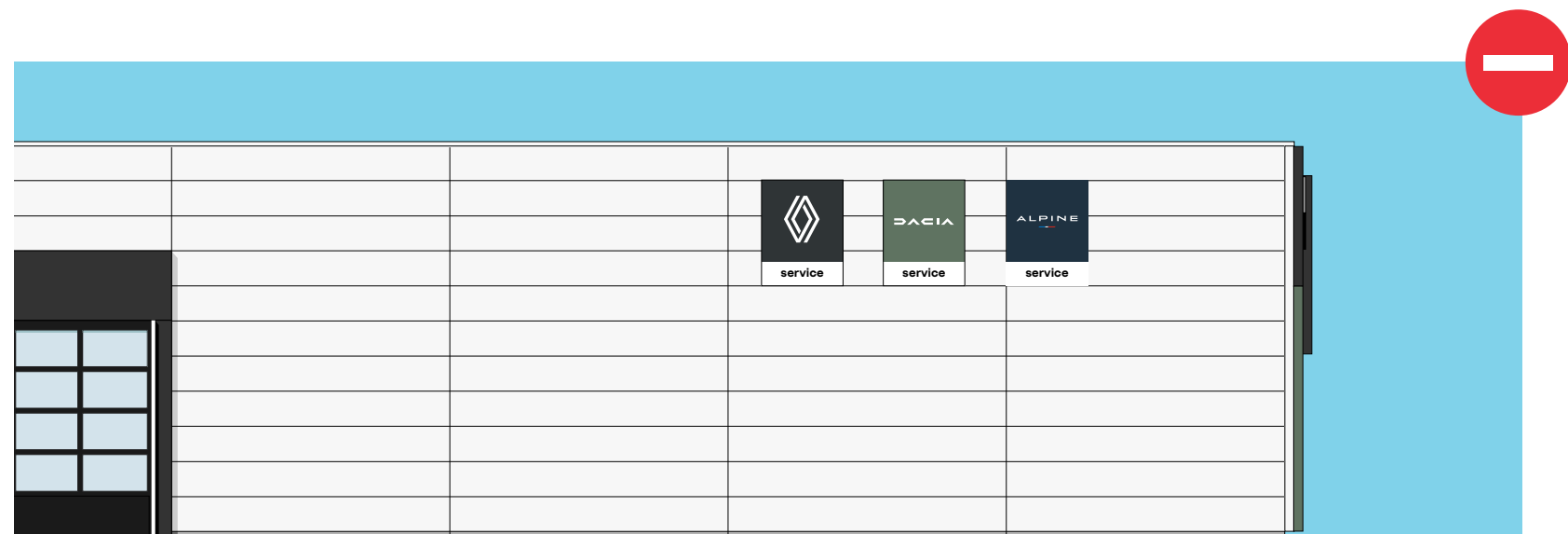
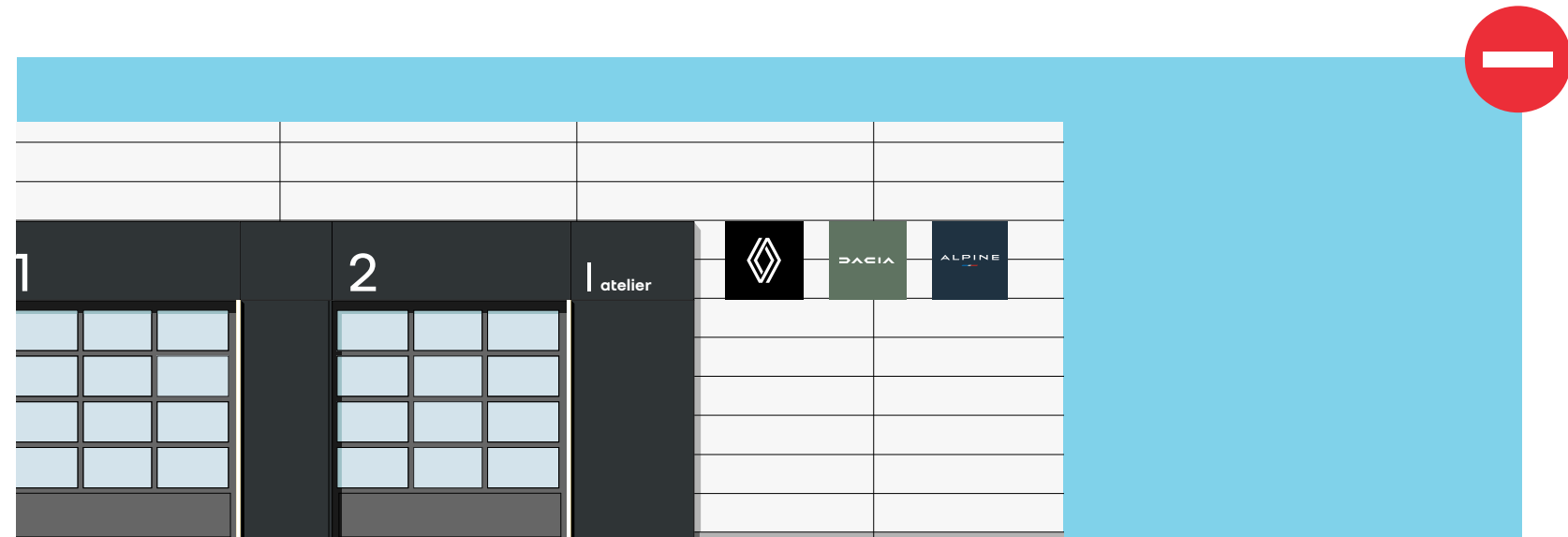

### DON'T

The Alpine brand must not appear on the after-sales facades since the Alpine customer never goes directly to the after-sales area.

- 1 Integration of the Alpine brand on a wall plate next to the workshop bays.
- 2 Alpine Service wall plate remote from the workshop bays.

## 11.5.3 After-sales area

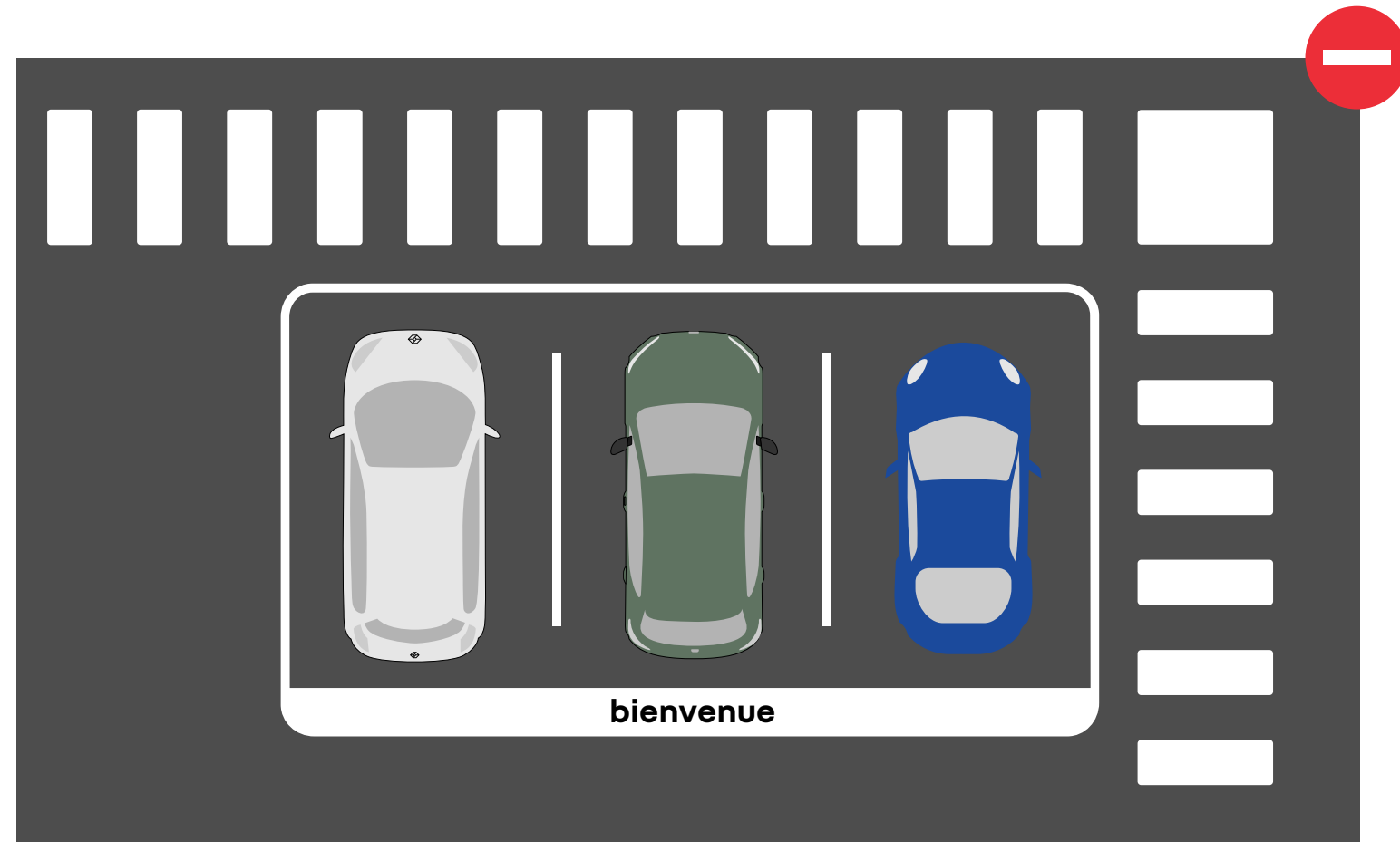

### GENERIC PRINCIPLE

As part of maintenance and repair operations, Alpine customers come to the showroom to be greeted by the Alpine advisor.

- 1 Alpine customers do not have to go through the Tour of vehicle zone to carry out maintenance or repair operations on their vehicle.

## 11.5.4 Service reception

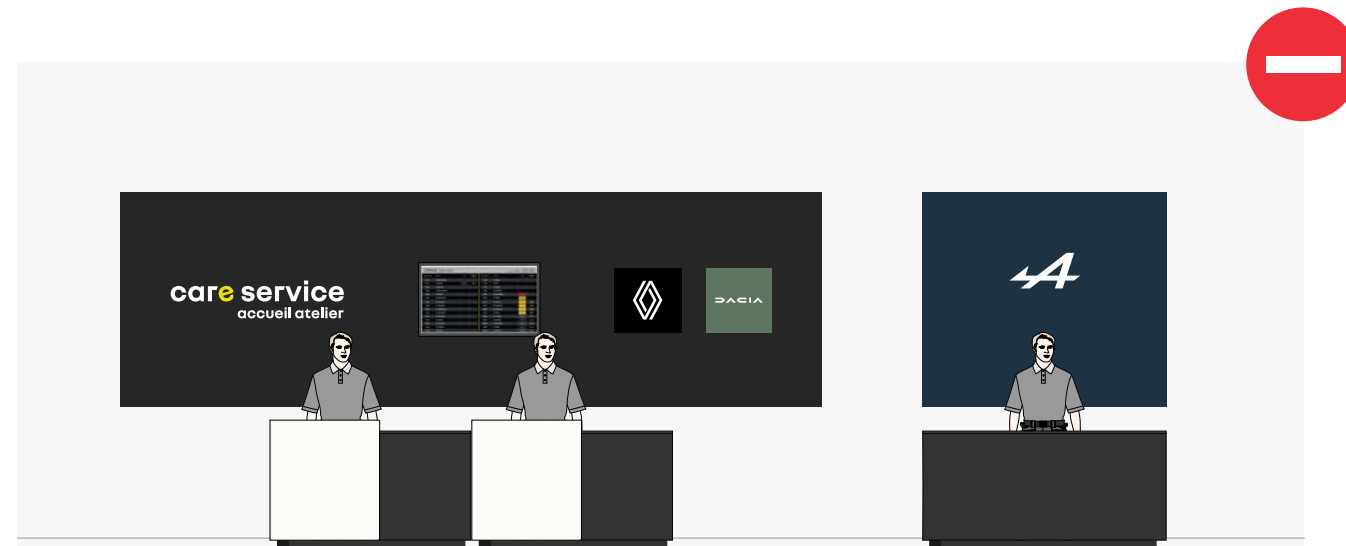
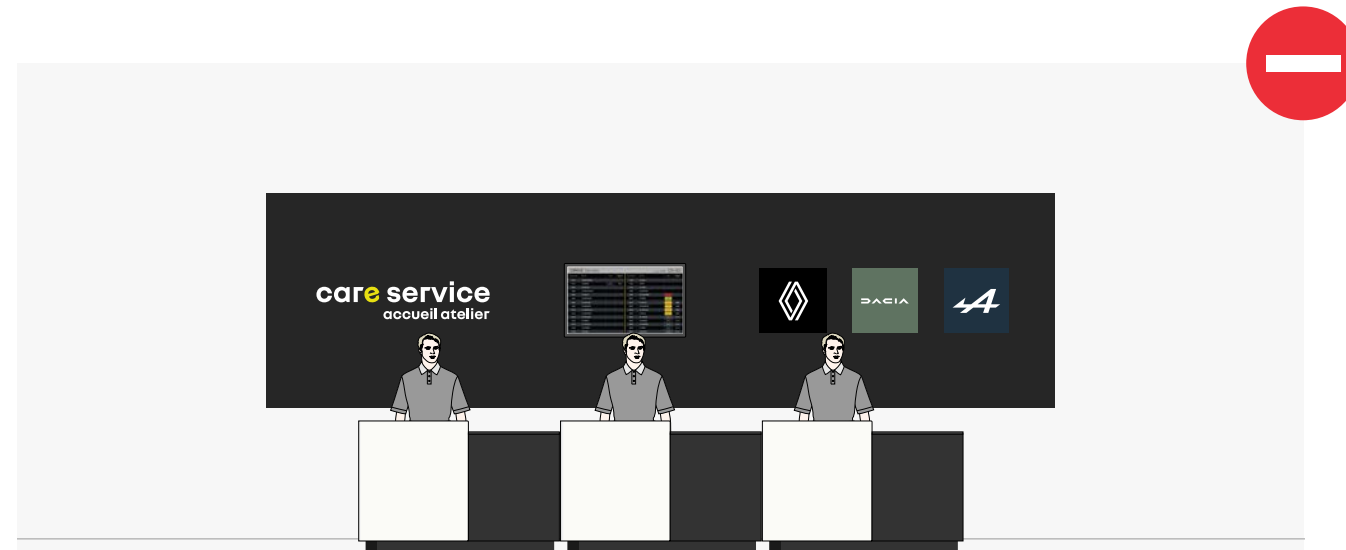

### PRINCIPLE

Reception of Alpine customers as part of after-sales operations is always done in the Alpine showroom.

### DON'T

- 1 Integration of another brand identity in the service reception wall fresco.
- 2 After-sales reception identified with the Alpine brand in the same space.

11.6

OTHER COMMON SERVICES

## 11.6.1 Fundamentals

### **Generic rule**

Delivery of Alpine vehicles and the presentation of Alpine certified vehicles always take place in the Alpine showroom (or in front of it).

### **Don't**

The care service 24/7 zone must not be used by Alpine customers.

Alpine certified vehicles must not be presented in the renew exhibition area.

## 11.6.2 Used cars

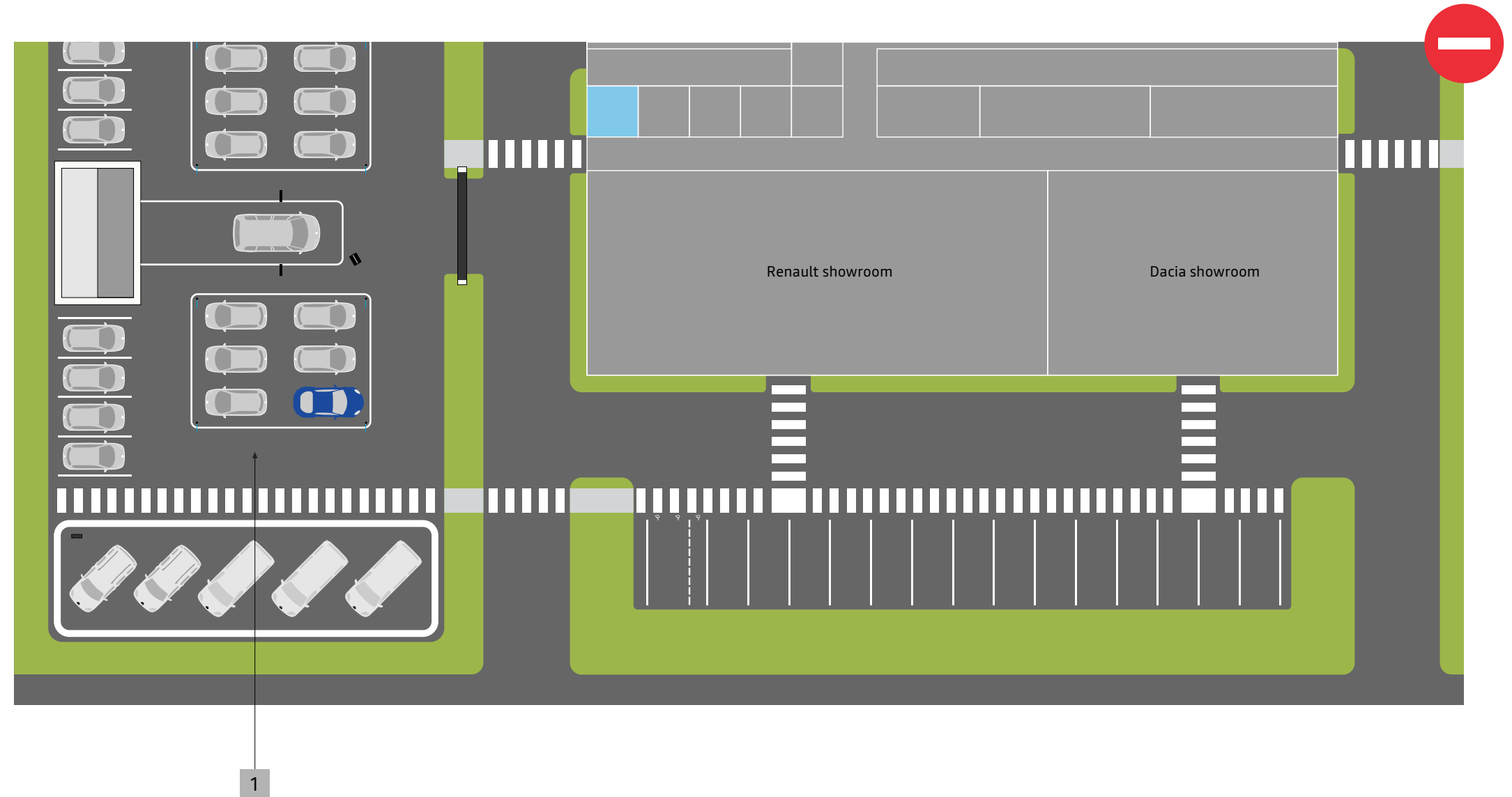

DON'T

**Alpine certified used vehicles are never presented in the renew exhibition.**

Alpine used vehicles are displayed in the Alpine showroom alongside new models.

1 renew exhibition.



### 11.6.3 Care service 24/7 zone

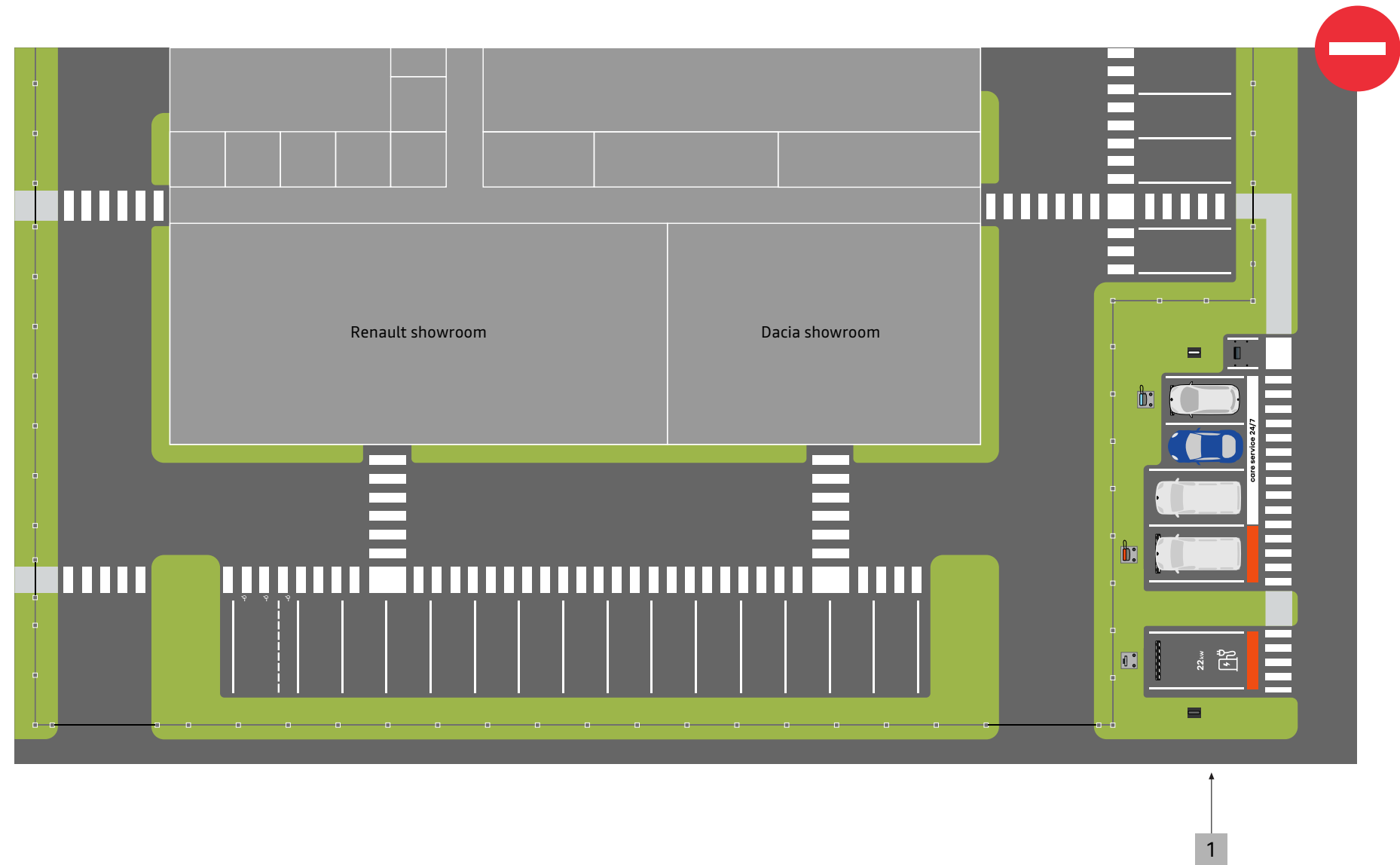

#### GENERIC PRINCIPLE

As part of maintenance and repair operations, customers of all brands can drop off or pick up their vehicle outside the site's opening hours.

This area is connected to the service reception via a protected passage (and access control).

**The care service 24/7 zone must not be used by Alpine customers.**

1 Care service 24/7 zone.

## 11.6.4 Renault Dacia delivery area

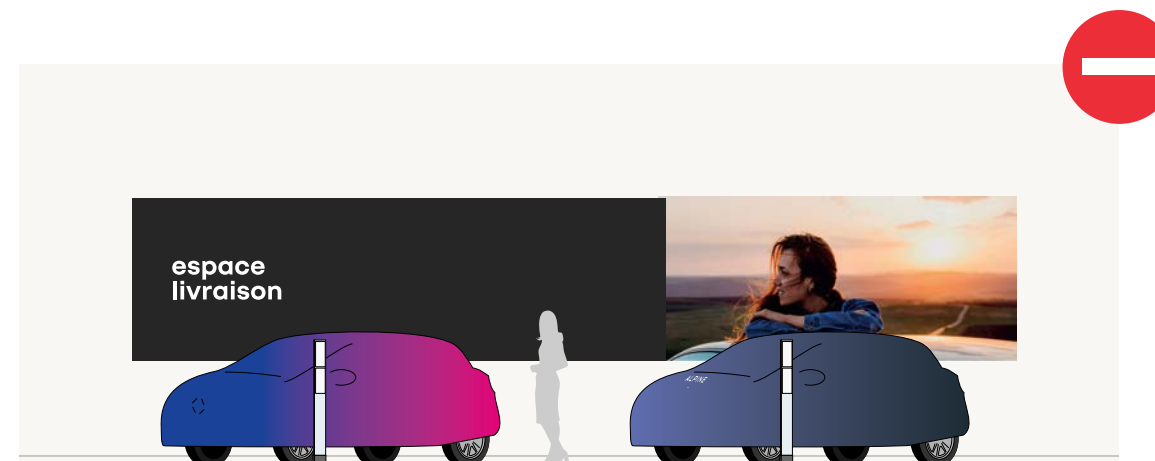

### PRINCIPLE

Delivery of Alpine vehicles is always done in the Alpine showroom.

### DON'T

- 1 Delivery of Alpine vehicles in the common area.