

# 4

## approaches

Entrance to the site	4.3
Directional signage	4.12
Customer parking areas	4.18
Pedestrian routes	4.30
Lighting of the site	4.44
Landscaping of the site	4.47

### customer-journeys at the centre of our thinking

Simplification of the customer-journeys is a key component of the development of our dealership network.

### guiding and informing customers as they approach the site

As they approach the site, our customers need to be guided and informed about what's new with the brand.

Effective directional signage simplifies their route onto the site and towards the parking spaces.

Everything is done to offer a view of the main façade and make the organization of the site as clear as possible.

### enhance and better manage the customer-journeys

The outdoor display areas are clearly visible from the approaches to the site, informing customers as to new products and inviting them to test drive the different models in the range.

From the parking spaces, our customers can take the pedestrian paths marked out on the ground to lead them to the showroom or after-sales reception points.

customers central  
to our  
**preoccupations**

approaches

## navigating easily on the site



### ① Entrance to the site

The unobstructed entrance area simplifies the reading of the façades and the perception of the general organization of the site.

### ② Directional signage and parking areas

The directional signage guides customers from the entrance to the site to the parking area.

### ③ Pedestrian routes

Pedestrian routes guide customers as they move around the site from the parking areas to the reception points. They connect the outdoor display areas to the showroom.

## entrance to the site presentation

### Make customer flows simple and safe right from the approaches to the site

The discovery of the site is an important moment in the customer experience.

The configuration of the main access should be perceived as simple and legible, even for customers discovering the site for the first time.



entrance to the site

## basic configurations

### The rules

Whenever possible:

- The entrance used by customers should be separate from that used by HGVs.
- The entrance and exit should be separate and one-way to avoid cross-flow.
- The entrance and exit should be arranged on either side of the outdoor display area.
- There should be a single customer entrance in order to simplify customer flows on the site.

### Note

These configurations can be adapted according to local traffic regulations.

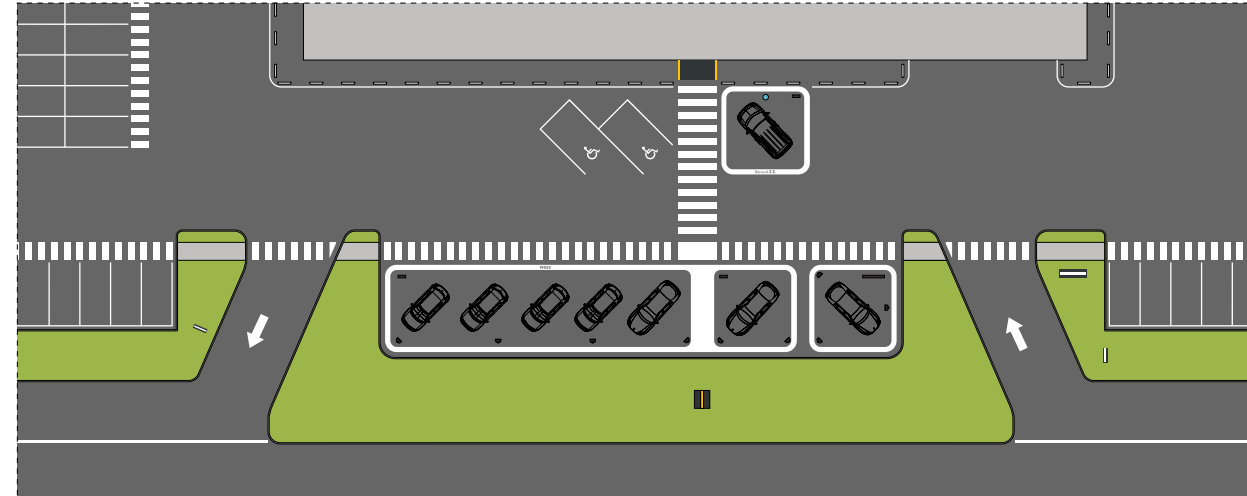

**BUSY ROAD**  
Entrance with deceleration lane and exit with acceleration lane

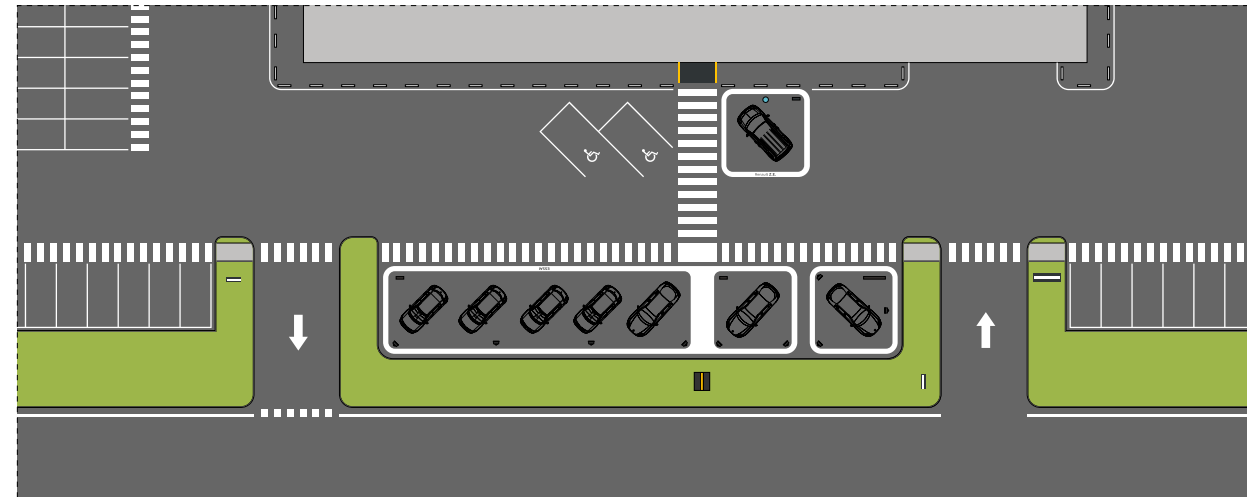

**QUIET ROAD**  
Entrance and exit at 90° with respect to the road



entrance to the site

## Entrance at 90° to road

### General rule

- The customer entrance to the site is positioned close to the Headline zone, itself located in front of the showroom on the main façade.

### Components

- ① Customer parking area
- ② Directional signage
- ③ Entrance sign
- ④ Headline zone
- ⑤ Totem
- ⑥ Other display zones

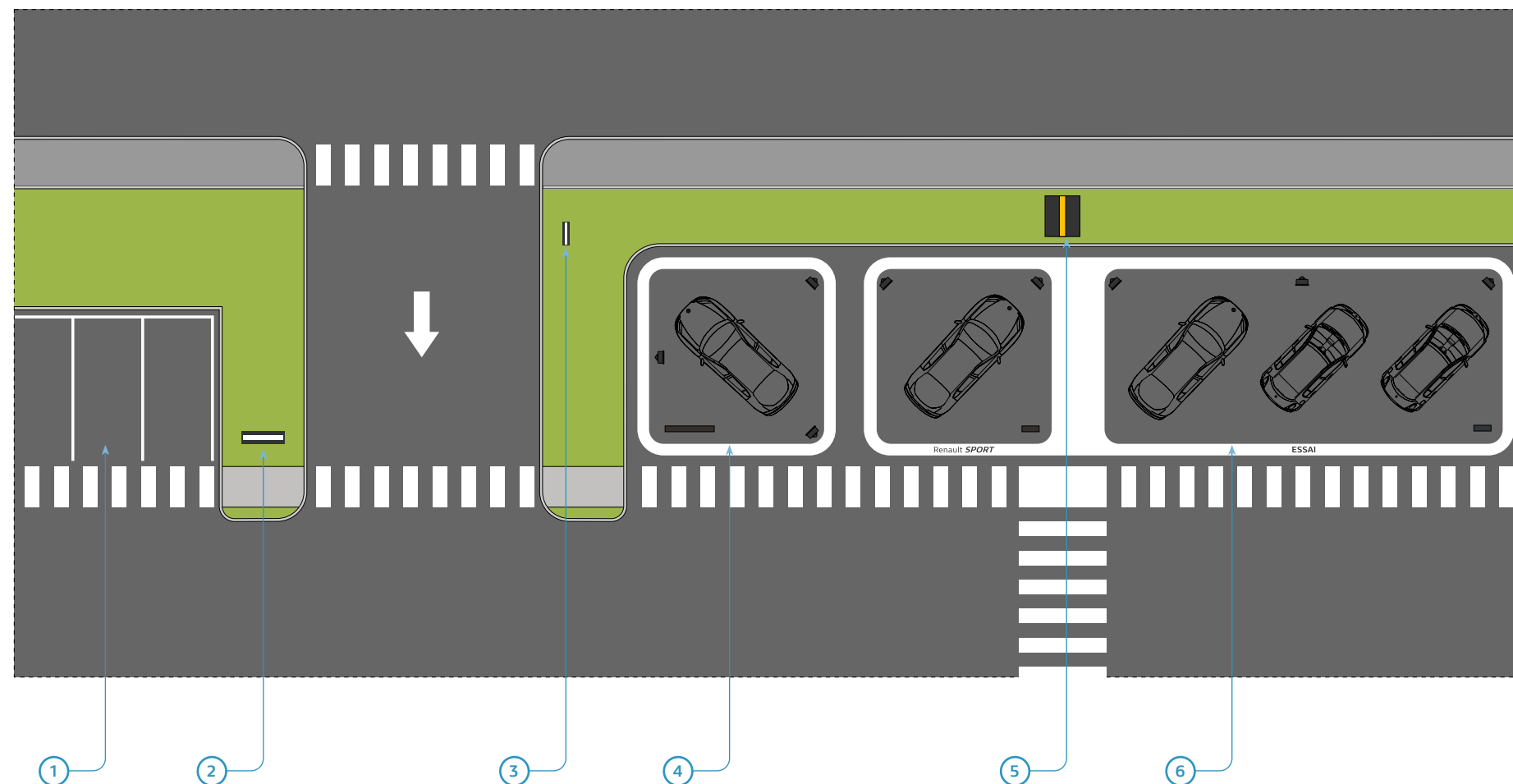

entrance to the site

## clear areas

### General layout 1

#### Components

- ① Customer parking area
- ② Directional signage
- ③ Entrance sign
- ④ Headline zone

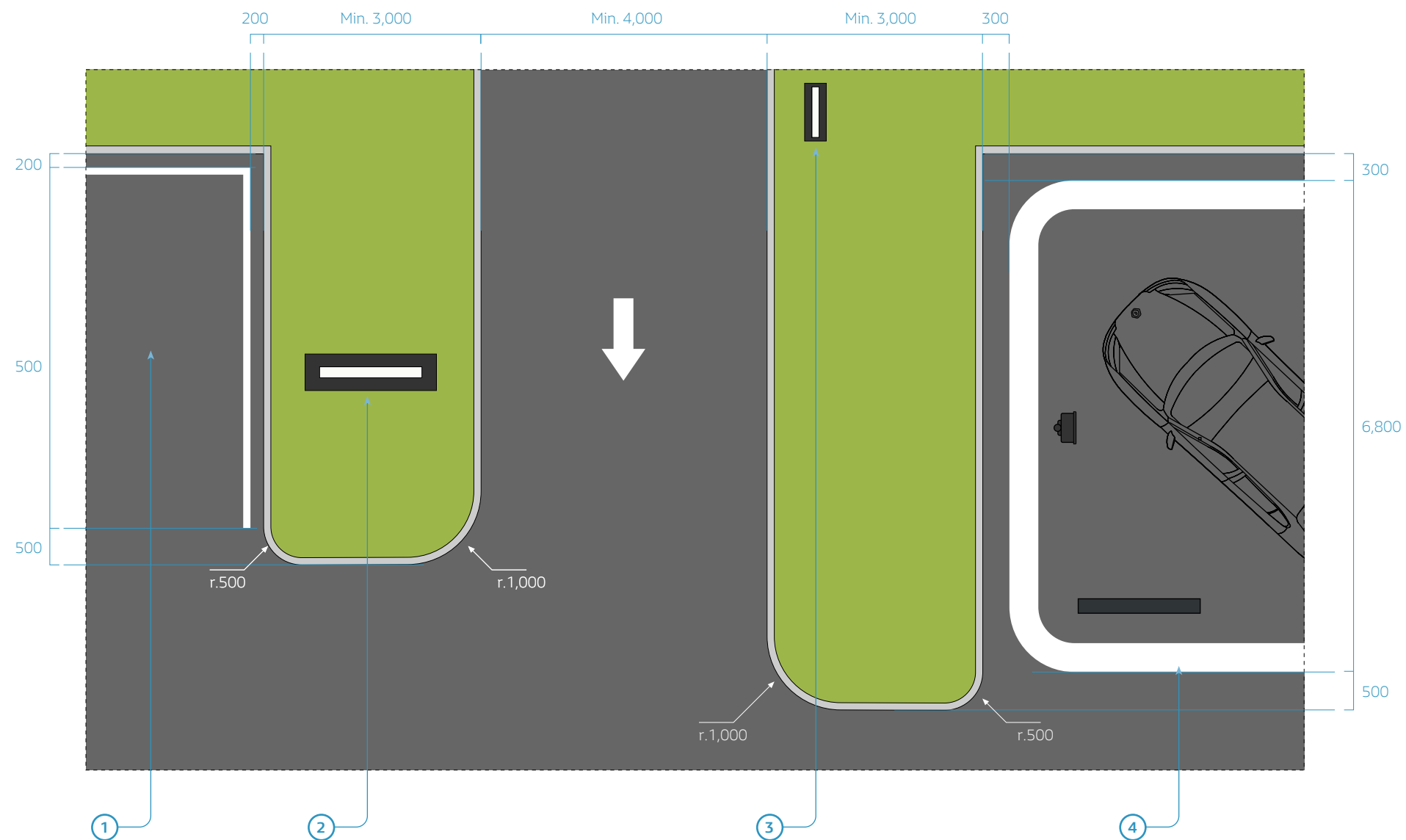



entrance to the site

## clear areas

### General layout 2

#### Components

- ① Customer parking area
- ② Pedestrian routes
- ③ Directional signage
- ④ Entrance sign
- ⑤ Headline zone

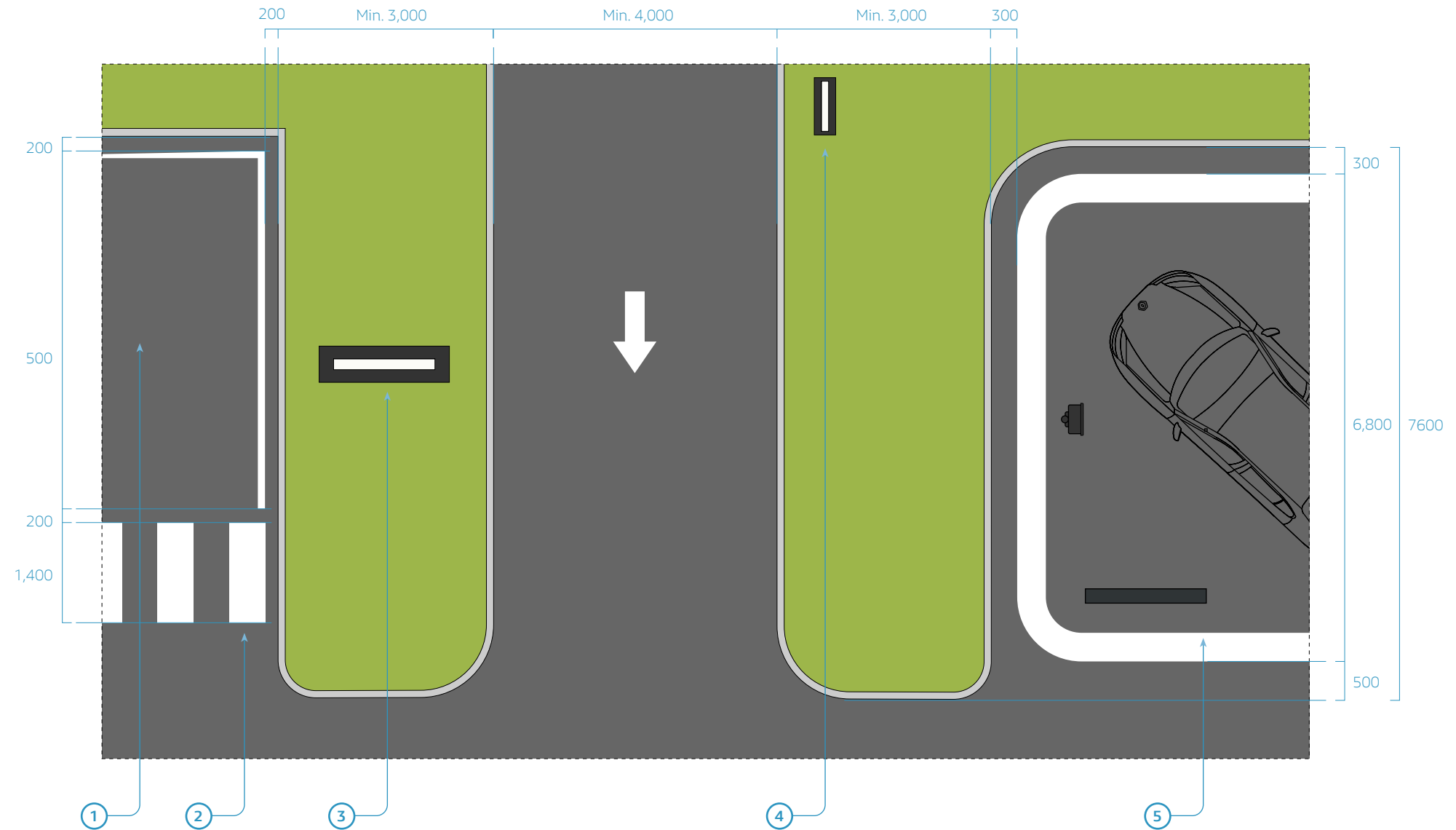

entrance to the site

## clear areas

### Border layouts 1

#### Economic variant

The clear space features finishing borders.

- ① Outside borders should have a radius of about 500 mm.
- ② Inside borders may be angled at 90°.

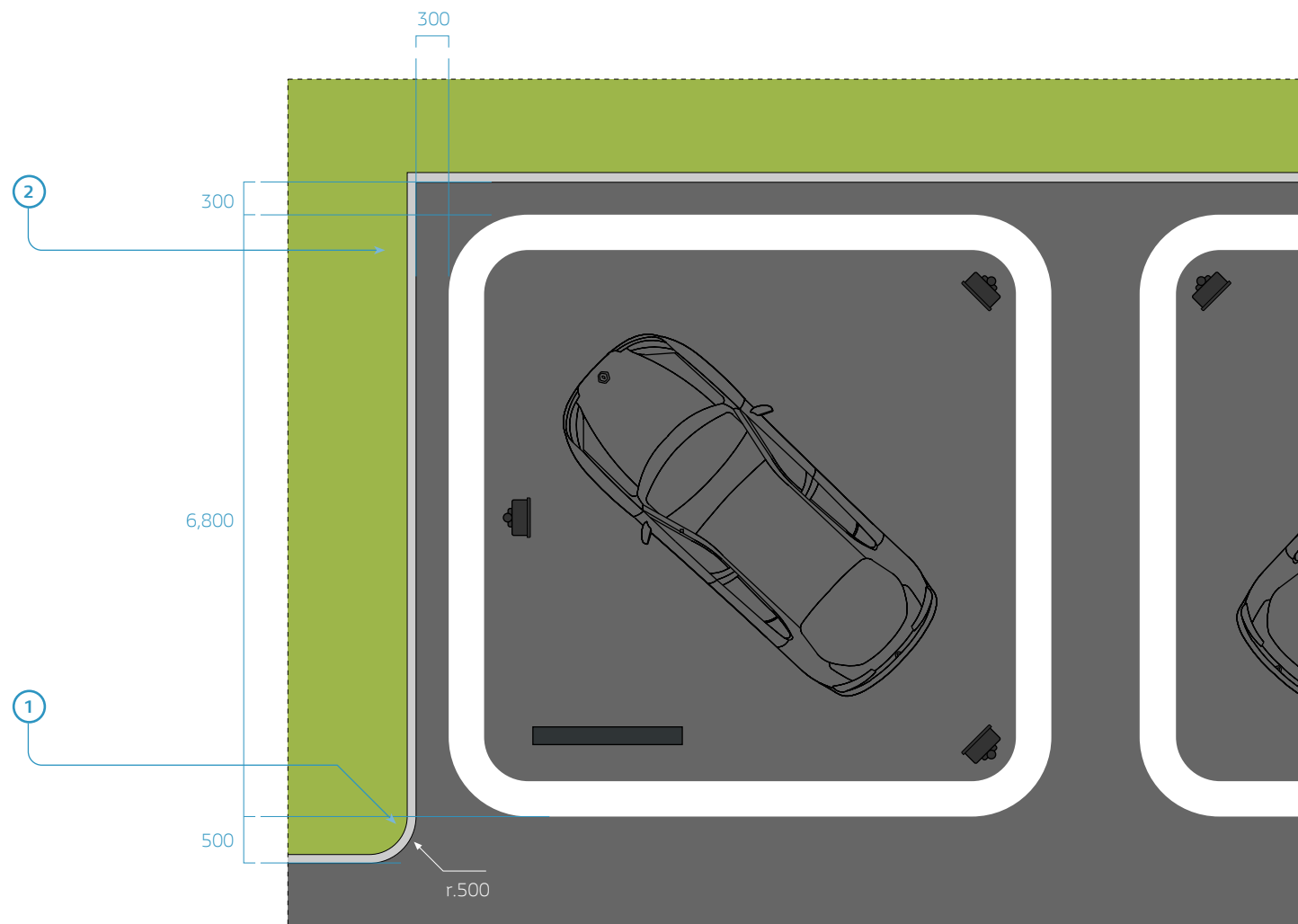

entrance to the site

## clear areas

### Border layouts 2

#### Basic recommendation

The clear space features finishing borders.

- ① Outside borders should have a radius of about 500 mm.
- ② Inside borders should have a radius of about 1,000 mm for consistency with the outline markings around the display zone.

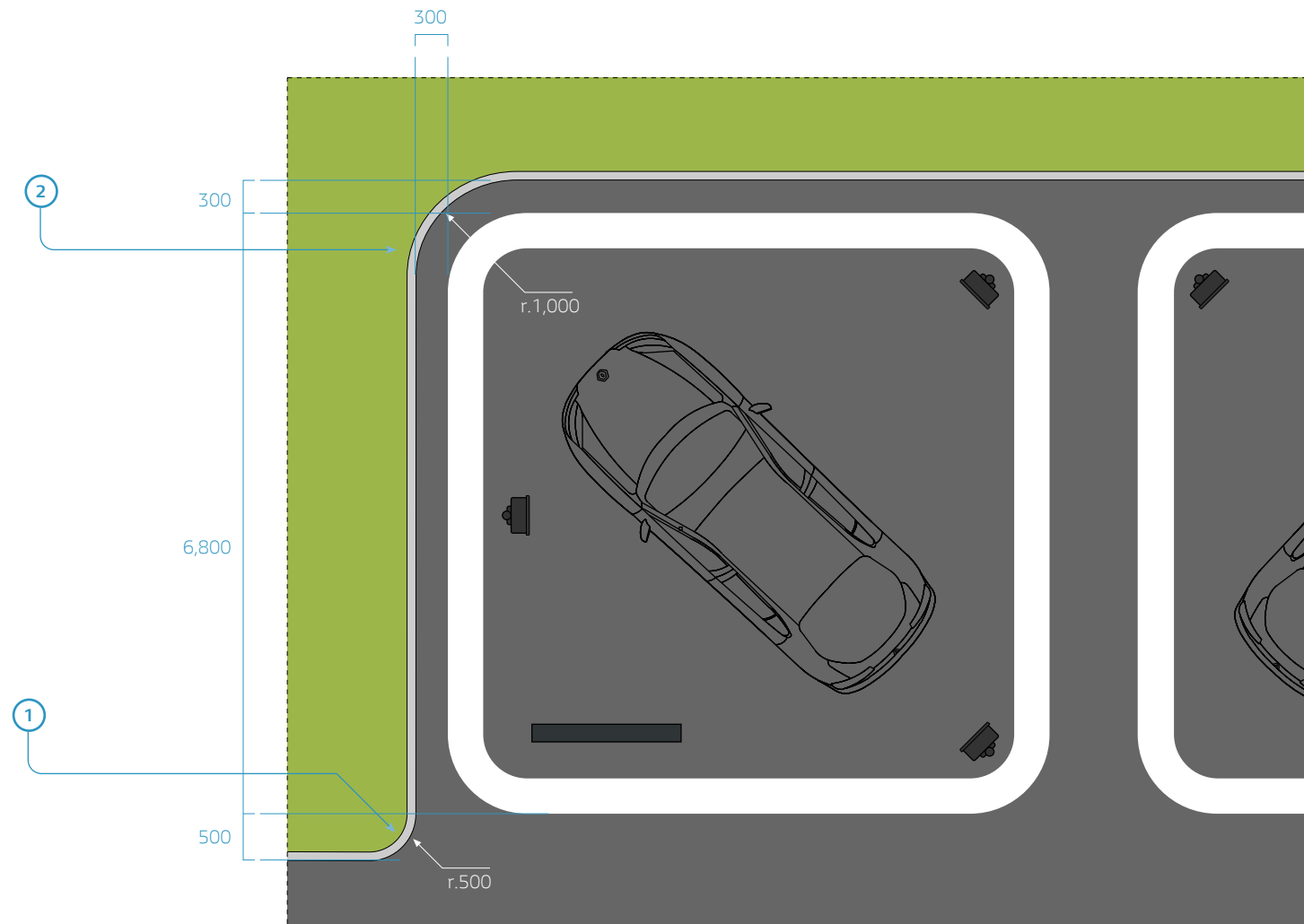

## directional signage presentation

### Purpose

The directional signage is arranged so as to signpost the customer journey from the approaches to the site to the customer reception areas.

This signposting only covers areas accessible to customers, including display areas and workshop.

There are two types of sign:

- ① directional signs,
- ② entrance-exit signs.



directional signage

## the different models

### A maximum of 4 texts per side

The directional signs have a height of 2,300 mm.

They may accommodate up to 4 indication texts, front and rear.

### Organization of the texts

- ① The texts read from the top down.
- ② The texts featuring higher up the sign are the closest "destinations".
- ③ The texts are then grouped by arrow direction.

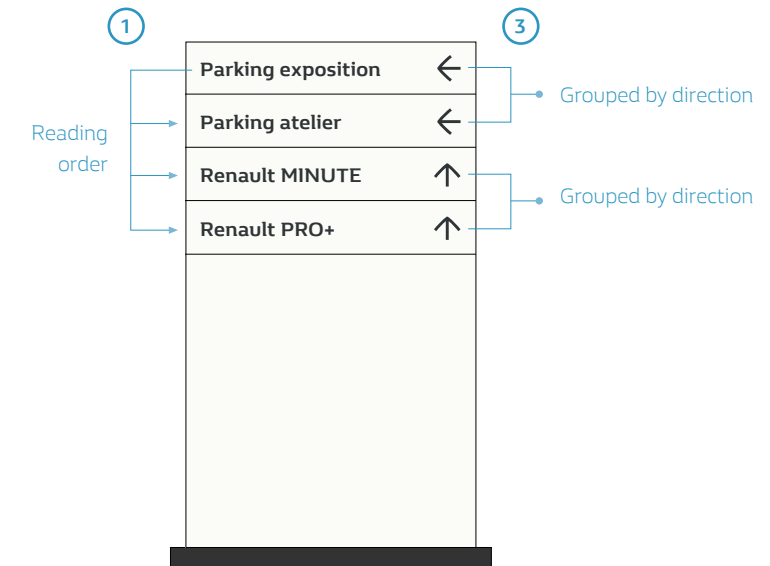
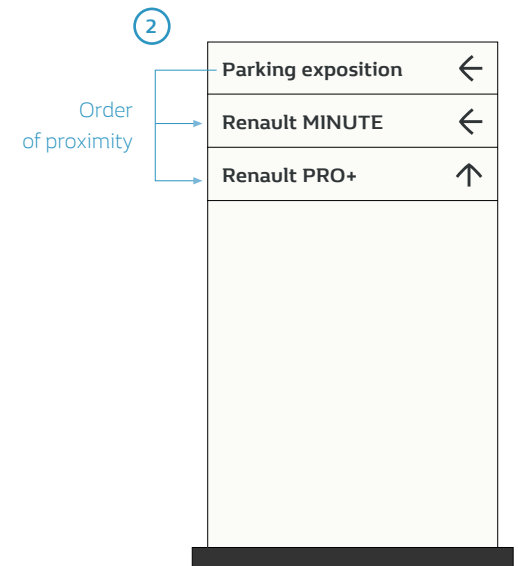
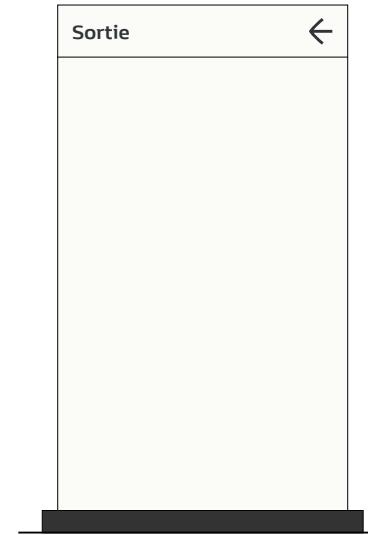

# directional signage a flow logic

① Direct the customer to a contact point  
The directional sign guides customers from the entrance to their destination.

② **Indicate the exit clearly**  
Depending on the configuration, the directional sign may also indicate the site exit.

It contributes to the safety of everyone at the site by organizing the flow of vehicles.

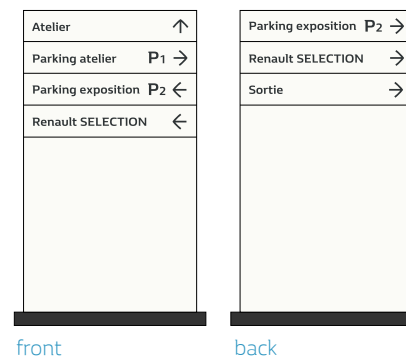
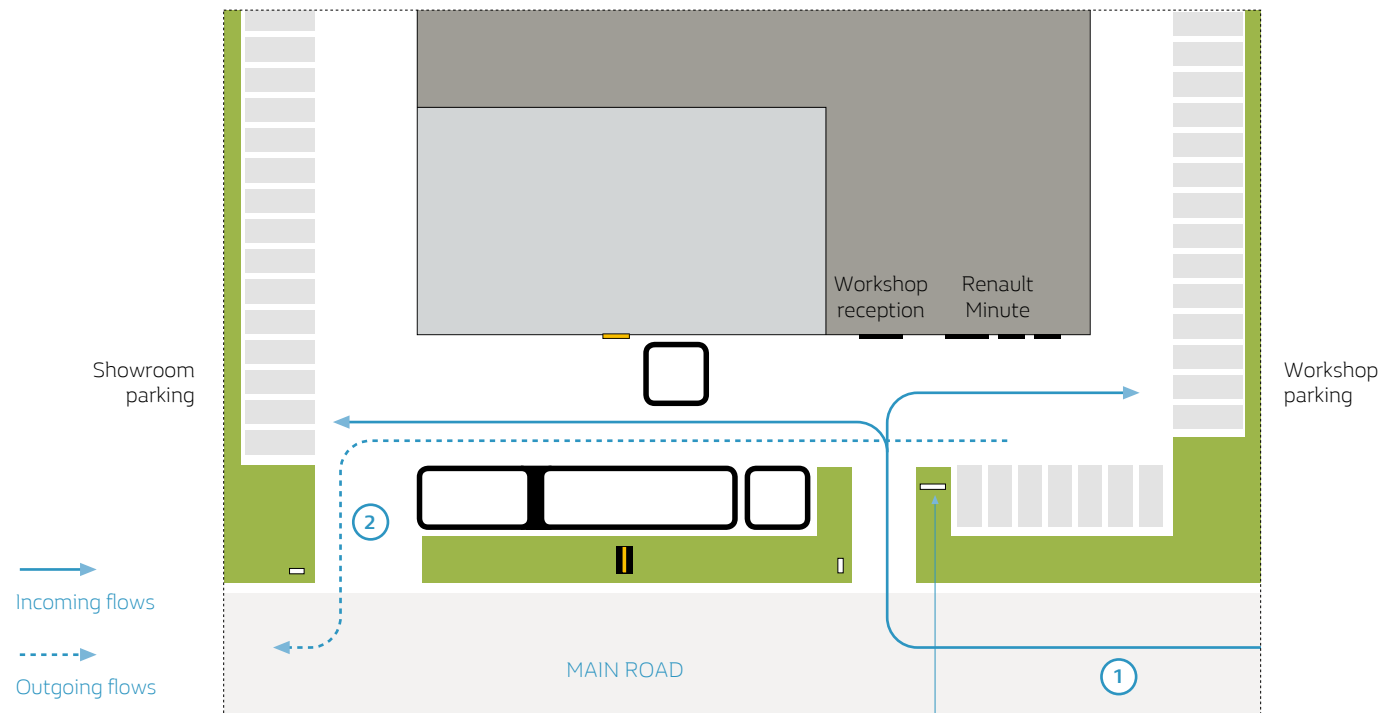

A limited number of messages is sufficient for customers to find their bearings on the site:

- Reception
- Workshop reception,
- Workshop,
- Showroom parking,
- Workshop parking,
- Renault MINUTE,
- Renault PRO+,
- Renault SELECTION,
- Exit.

directional signage

## how do I arrange it?

### Rule 1.

**The directional signs are installed perpendicular to vehicle flows**

The directional sign should preferably be to the right of the entrance (depending on the country in question, the direction of flow may be reversed).

### Rule 2.

**The signage begins as soon as you enter the site.**

It responds to the customer's need for information, so that upon discovering the site, they can easily find their bearings thanks to simple instructions that tell them how the site is organized.

### Rule 3.

**The directional signs indicate the Exit to the site.**

The back of the directional sign can be used to signal the Exit.

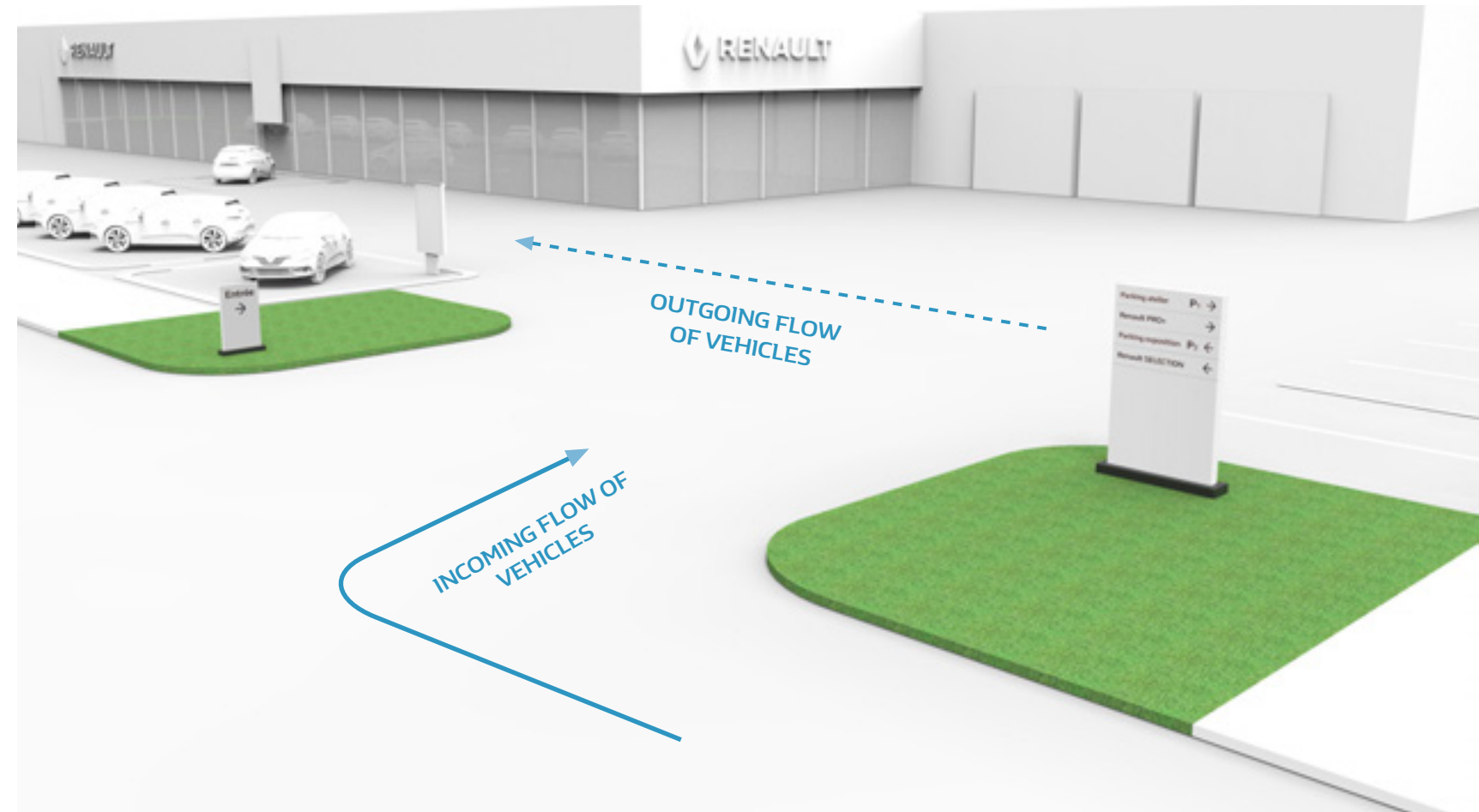

directional signage

## entrance-exit signs

### These are complementary to the directional sign

- ① The "Entrance" sign welcomes the customer onto the site.
- ② The "Exit" sign concludes the outbound signposting.

It is positioned perpendicular to the traffic when the entrance and exit are distinct.

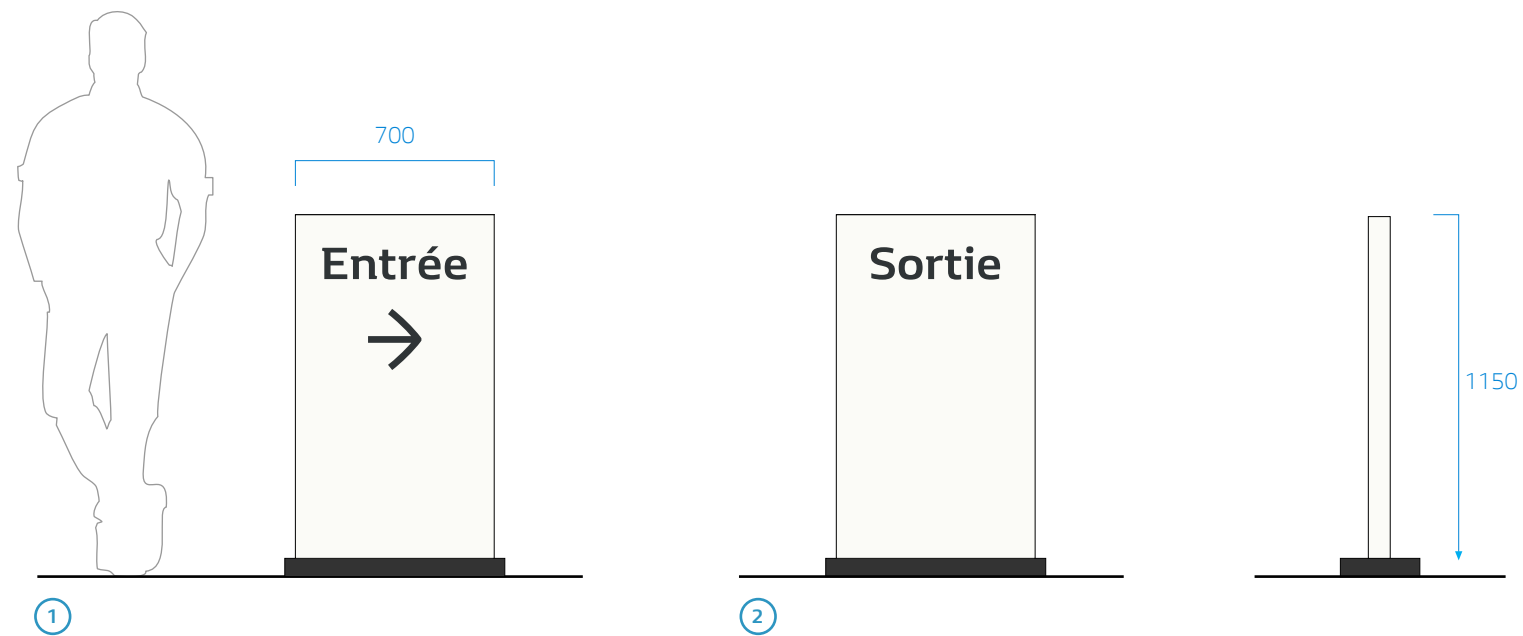



directional signage

## how do I arrange it?

### Simplify access to the site

- ① In the customer flow, the "Entrance" sign precedes the first directional sign.

### Indicate the exit clearly

- ② The back of the "Exit" sign, facing the road, signals to customers that this route is not to be used to access the site.

Depending on the configuration, the directional sign may also indicate the site exit.

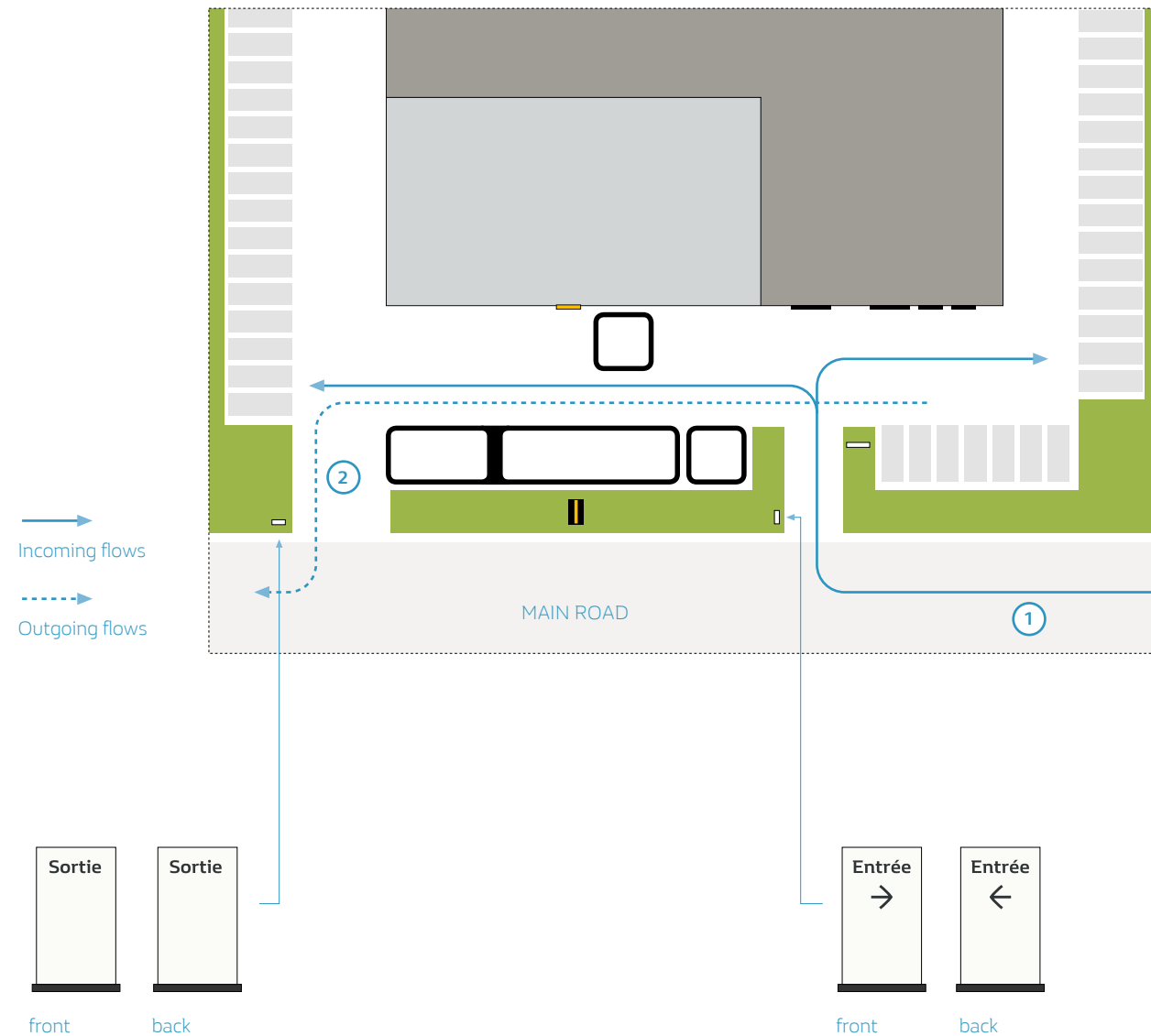

## customer parking areas presentation

### Purpose

Access to customer parking areas area subject to careful treatment:

- ① An identification sign for the parking area tells customers where they can park.
- ② Markings on the ground materialize the vehicle locations while protected walkways are provided to allow customers to access the site reception points (showroom and after-sales).



## customer parking areas

### the parking sign

#### A component derived from the Test drive area mast

The parking sign bears the indication "P1" or "P2" (in some cases "P3", etc.) at the top, used to distinguish the customer parking area for the showroom from the area for the workshop.

- ① The parking sign has a white background and is 3 m in height.
- ② The indications "P1" and "P2" are repeated on both sides of the directional sign so that the guidance is coherent.

If there is no possibility of installing a parking sign, provide markings on the ground.

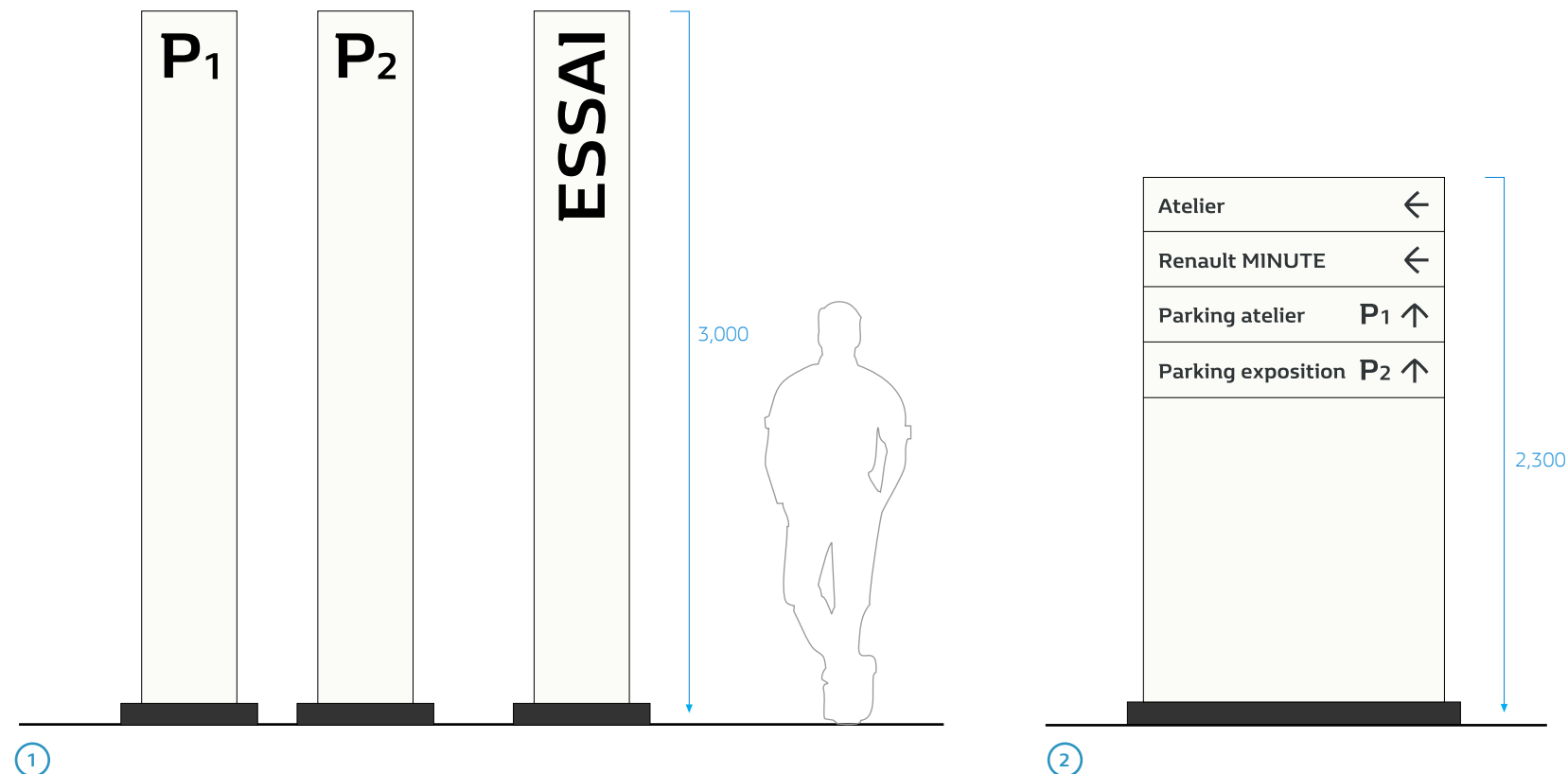

## customer parking areas a flow logic

### ① Directing customers to the parking area corresponding to their visit

The directional sign indicates the parking areas, par exemple :

- Workshop parking P1
- Showroom parking P2

### ② Identifying the parking areas

A parking sign identifies each of the customer parking areas with the indication "P1" or "P2", etc.

### Rule

The numbering of parking spaces is in order of proximity to the first directional sign.

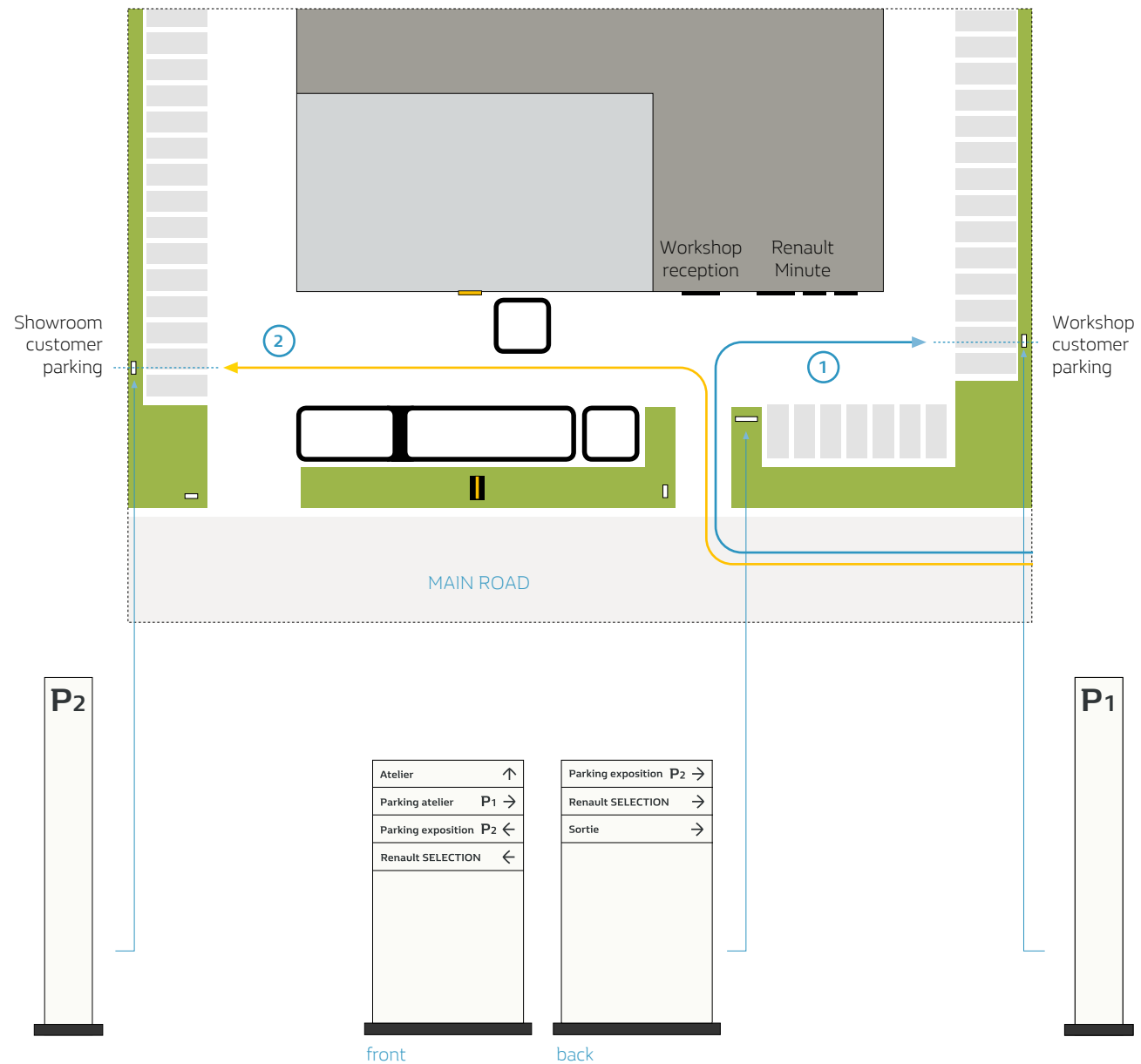

customer parking areas

## how do I arrange it?

### Rule 1.

**The identification sign for the parking areas shall be positioned facing the parking spaces**

The parking sign is positioned on a clear space adjacent to the customer parking spaces, if possible in line with the customer flow.



### Rule 2.

**The indications P1 & P2 are associated with the wording "Showroom parking" and "Workshop parking".**

This arrangement effectively guides customers to the parking area nearest to the reception point corresponding to purpose of their visit.

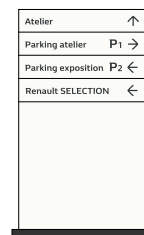

### Rule 3.

**The P1 or P2 parking indication may be repeated on the back of the directional sign for more clarity**

According to the configuration, this arrangement will help guide customers to the appropriate parking area.

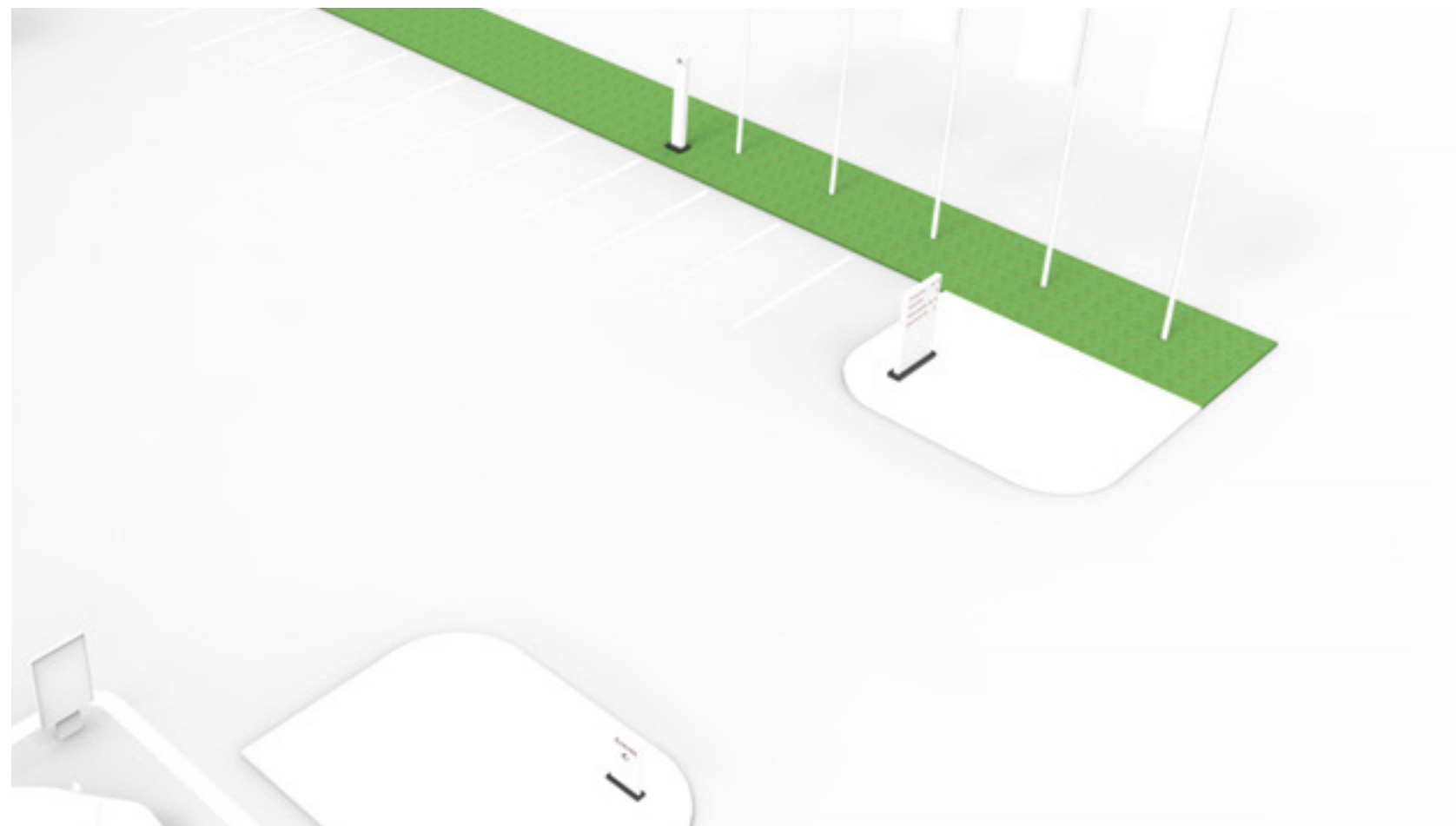

customer parking areas

## outlines for perpendicular spaces

### Sober, efficient treatment

- ① The parking spaces are delimited by white strips of constant width (100 mm) connected at right angles.
- ② The selected colour reference is RAL 9003.
- ③ The recommended dimensions are compatible with European standards, offering an additional width of 100 mm to take into account the general increase seen across the vehicle range, in particular SUVs.

If there is no possibility of installing a parking sign, provide markings on the ground.

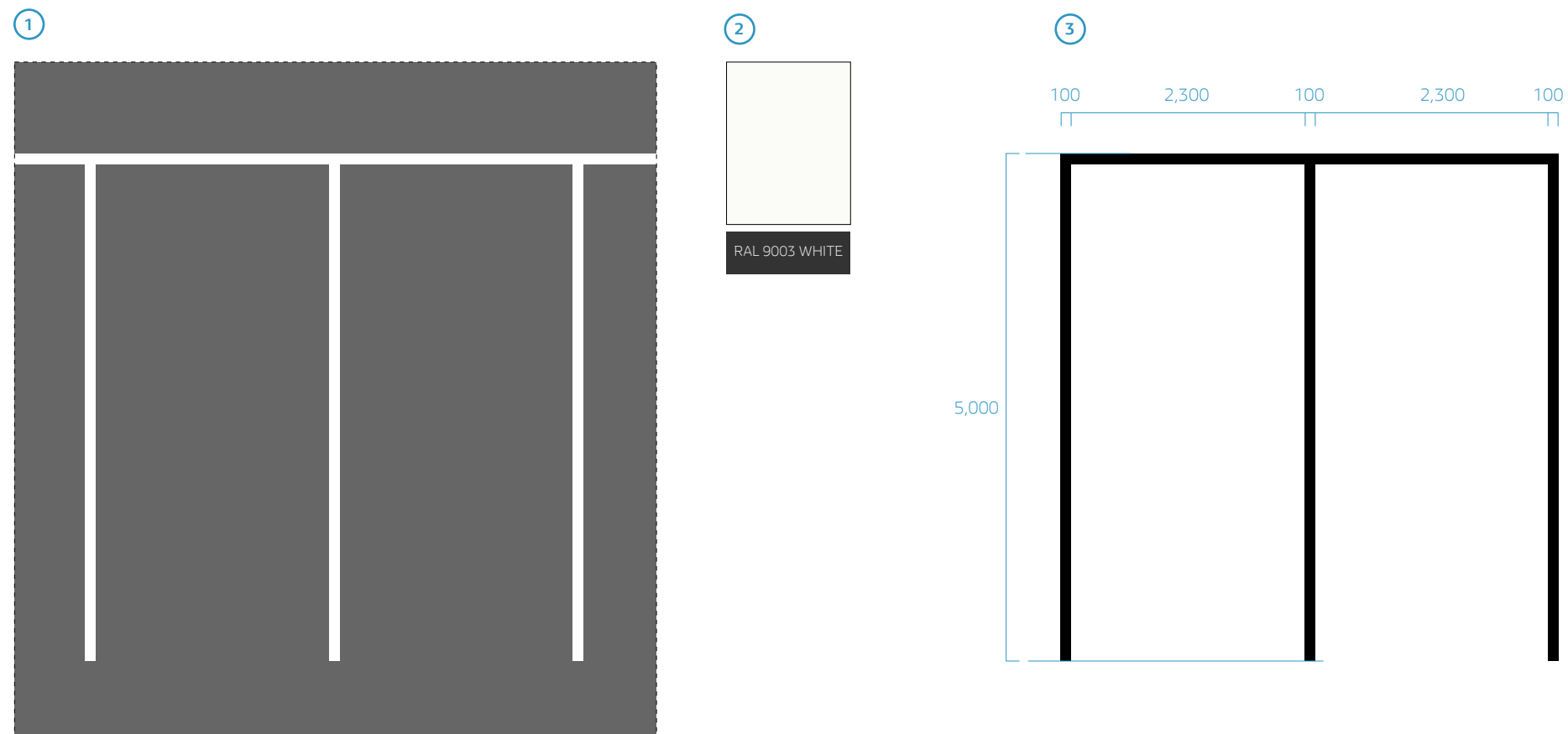

Installation of parking spaces with no clear space

customer parking areas

## outlines for perpendicular ZE spaces

### Same outline as for other parking spaces

- ① The charging station can either be shared between 2 spaces, or installed individually.
- ② ZE parking spaces are characterized by the ZE charging pictogram and the specific blue colour.
- ③ The challenge is to have ZE spaces cohabit within the customer parking areas, in particular when charging stations are already installed on the site.

①

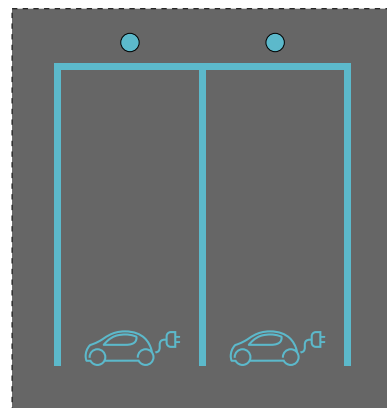

Implementation of individual charging stations

②



③

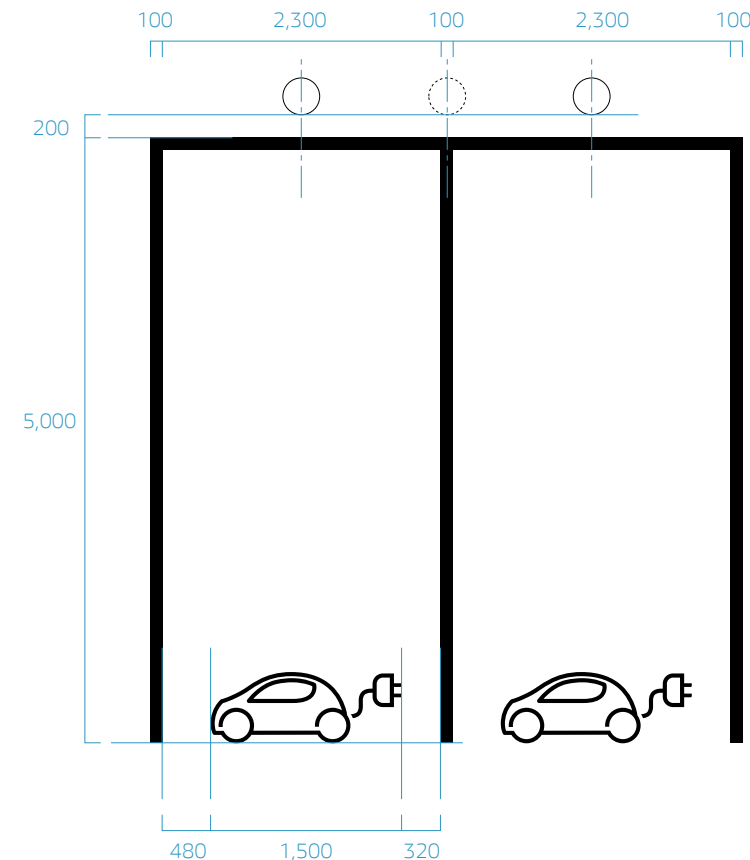

Implementation of a common charging station for 2 parking spaces

customer parking areas

## outlines for 45° angled ZE spaces

### A layout for installation in front of the showroom

- ① The charging station can either be shared between 2 spaces, or installed individually.
- ② ZE parking spaces are characterized by the ZE charging pictogram and the specific blue colour.

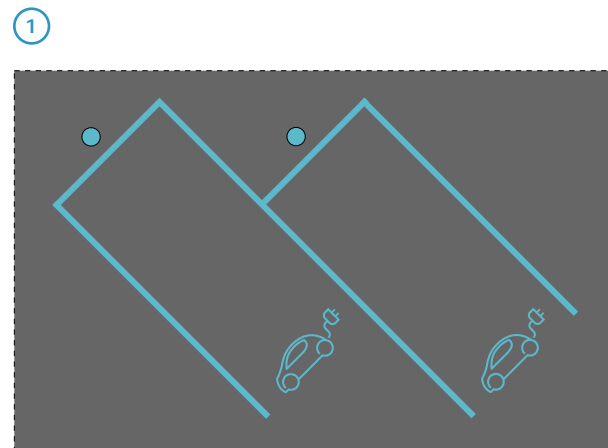

Implementation of individual charging stations

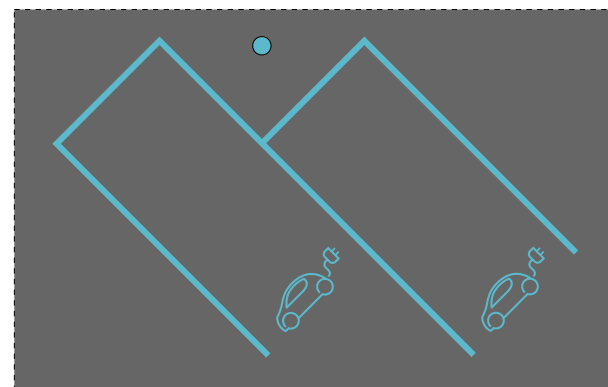

Implementation of a common charging station for 2 parking spaces

②

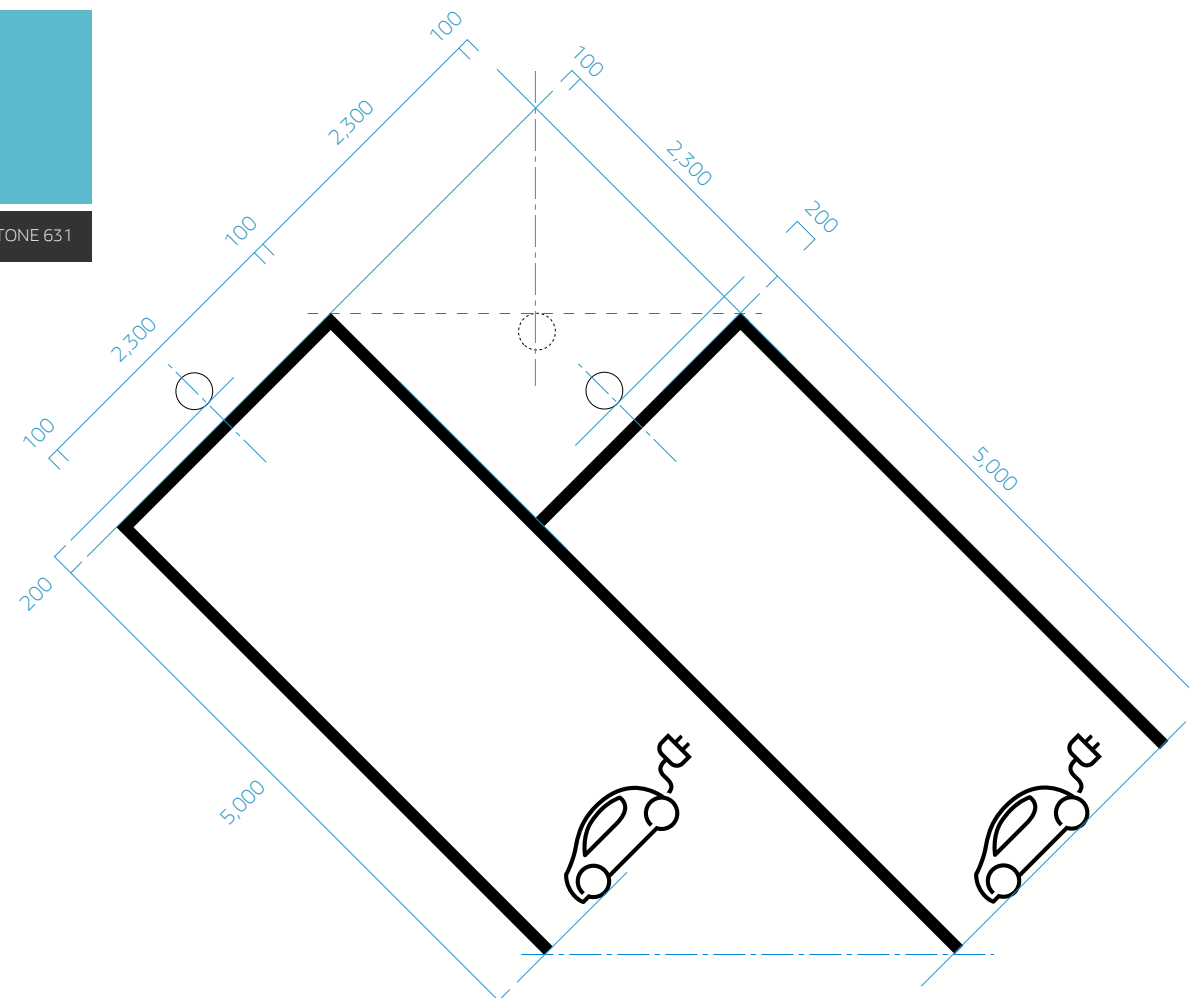



customer parking areas

## outlines for perpendicular PRM spaces

### Different outline from the other parking spaces

- ① PRM parking spaces are characterized by a specific pictogram.
- ② To enhance visibility, it is possible to apply a blue colour on the entire surface of the parking space reserved for PRM.
- ③ The parking spaces meet standards defining the minimum dimensions.

The width of these spaces is increased relative to those of standard spaces.

### Note

Regulations may specify a minimum number of PRM spaces according to the overall number of parking spaces (eg. 2% in France).

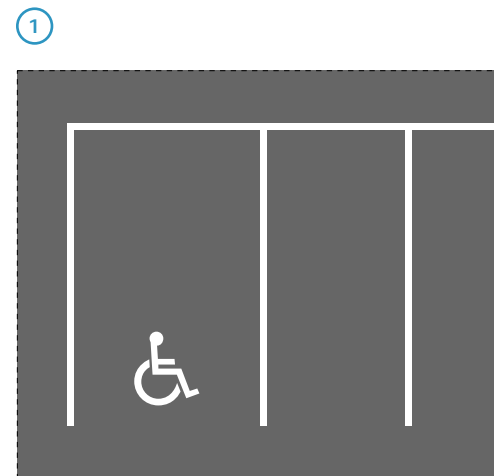

Recommendation

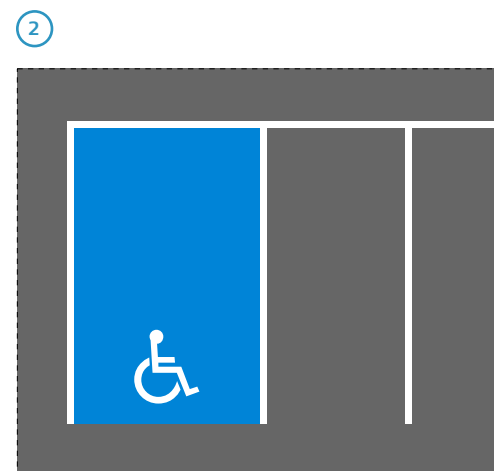

Variant

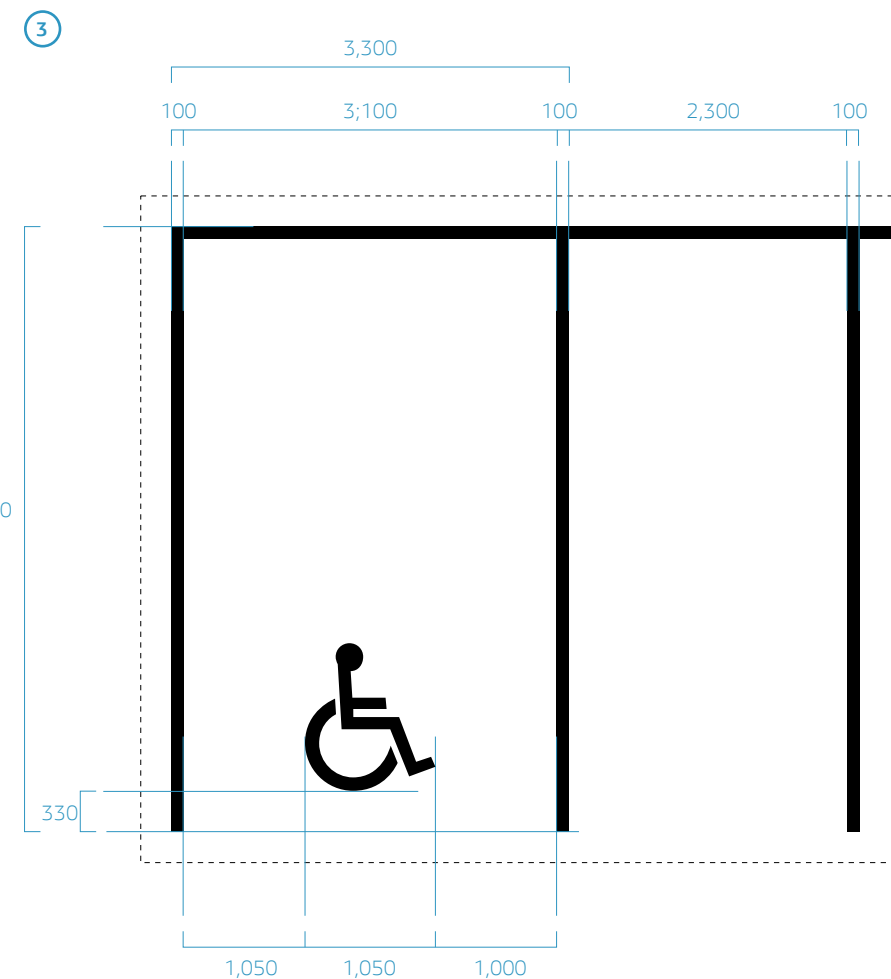

customer parking areas

## outlines for 45° angled PRM spaces

### A layout for installation close to the showroom

It may be wise to locate the PRM spaces near to the entrance of the showroom.

- ① PRM parking spaces are characterized by a specific pictogram.
- ② To enhance visibility, it is possible to apply a blue colour on the entire surface of the parking space reserved for PRM.
- ③ The parking spaces meet standards defining the minimum dimensions.

### Note

When creating new parking spaces, the regulations require PRM spaces to be located as close to the reception points as possible (for France).

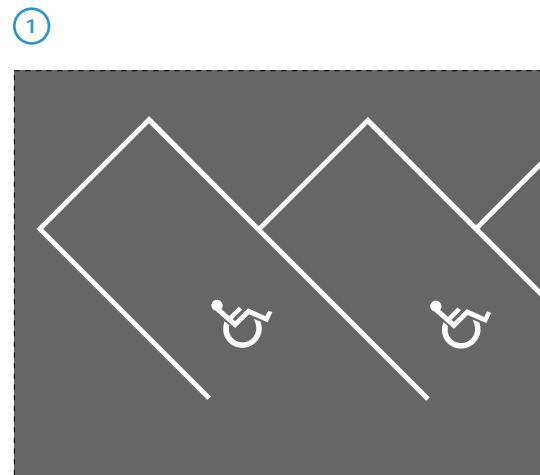

recommendation

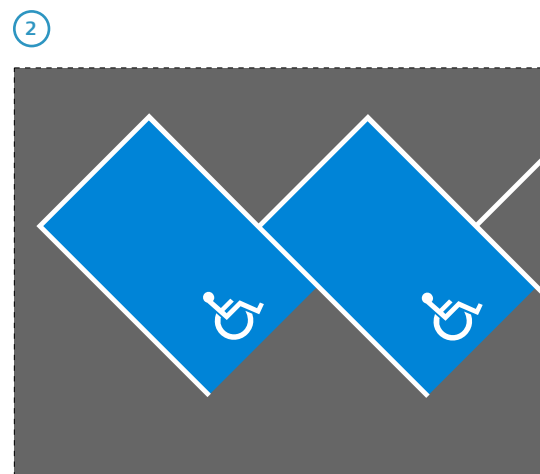

Variant

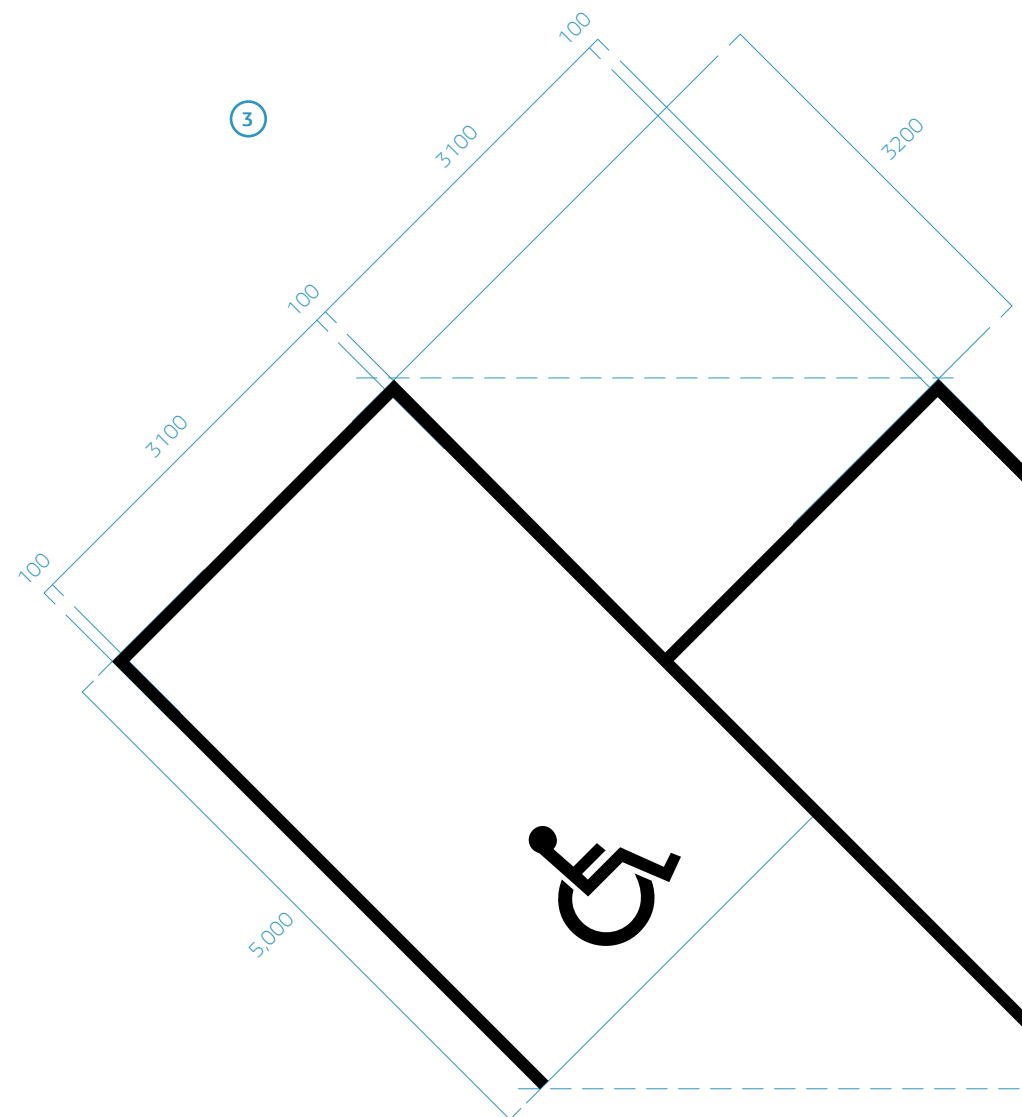

customer parking areas

## parking spaces with clear space

### Simplification of outline

If the parking space is set against a clear space, only apply the strips that delimit the spacing between cars, the front strip being dispensed with.

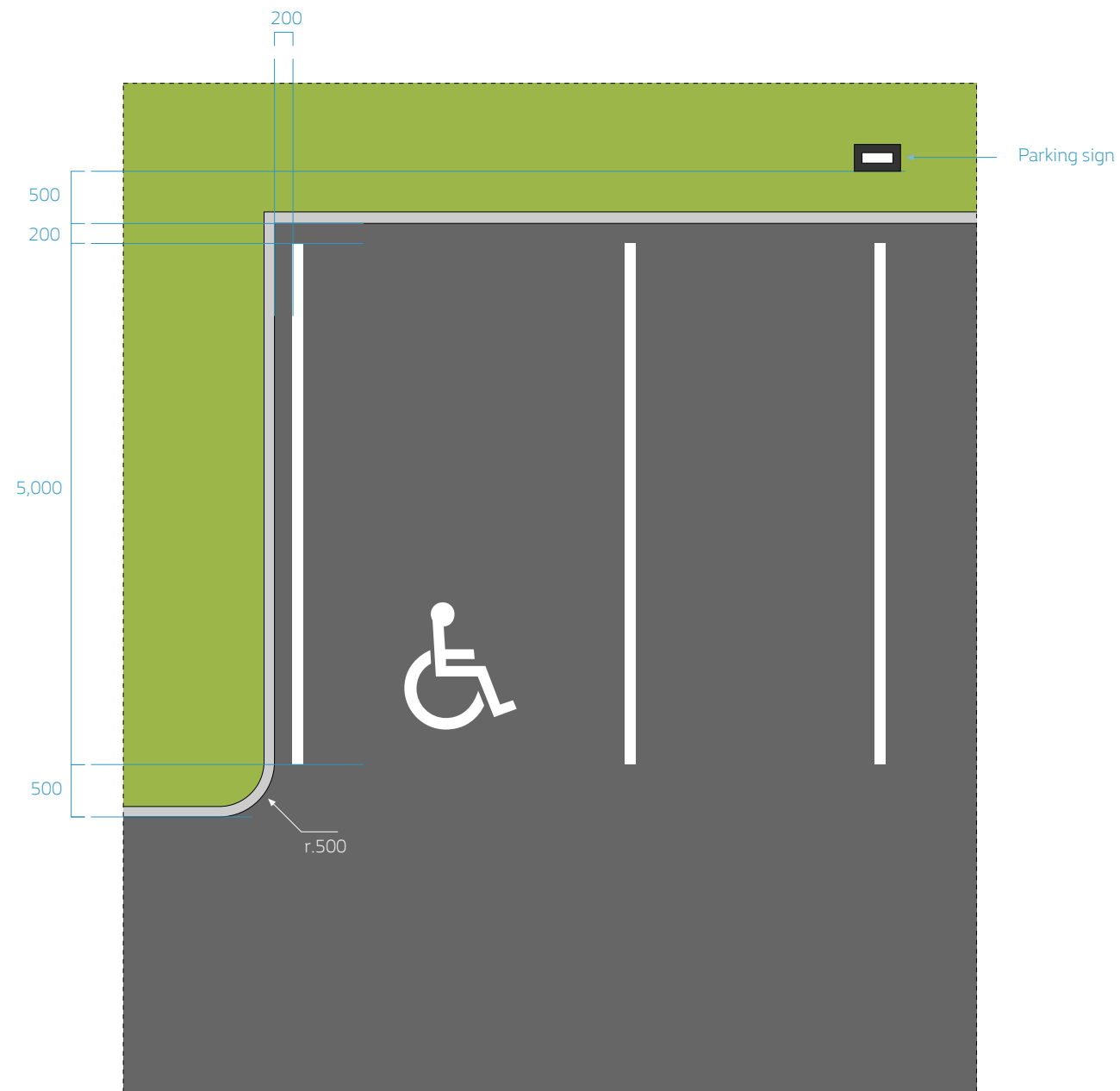

customer parking areas

## parking spaces with adjacent walkway

### Recommendation currently becoming generalized

Wherever possible, it is recommended to mark out pedestrian routes for customers both for safety reasons and in order to meet increasingly constraining regulations.

The protected pedestrian routes marked on the ground shall lead customers from the parking areas to the reception points (showroom or after-sales).

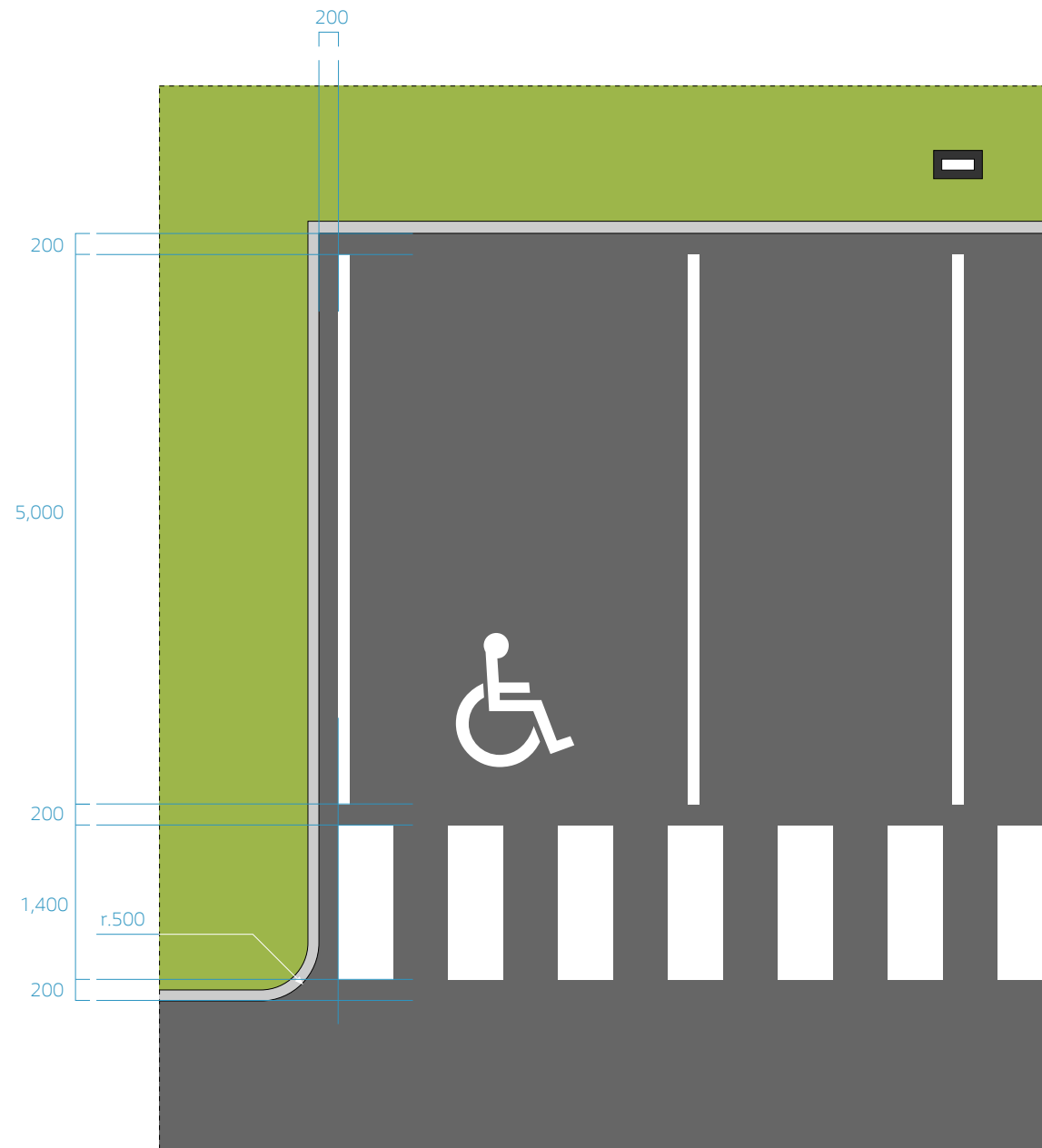

customer parking areas

## parking spaces on 2 rows

### A variant to optimize parking space

Parking areas may be arranged in 2 rows in order to optimize the number of spaces.

Wherever possible, it is recommended to mark out pedestrian routes for customers both for safety reasons and in order to meet increasingly constraining regulations.

The protected pedestrian routes marked on the ground shall lead customers from the parking areas to the reception points (showroom or after-sales).

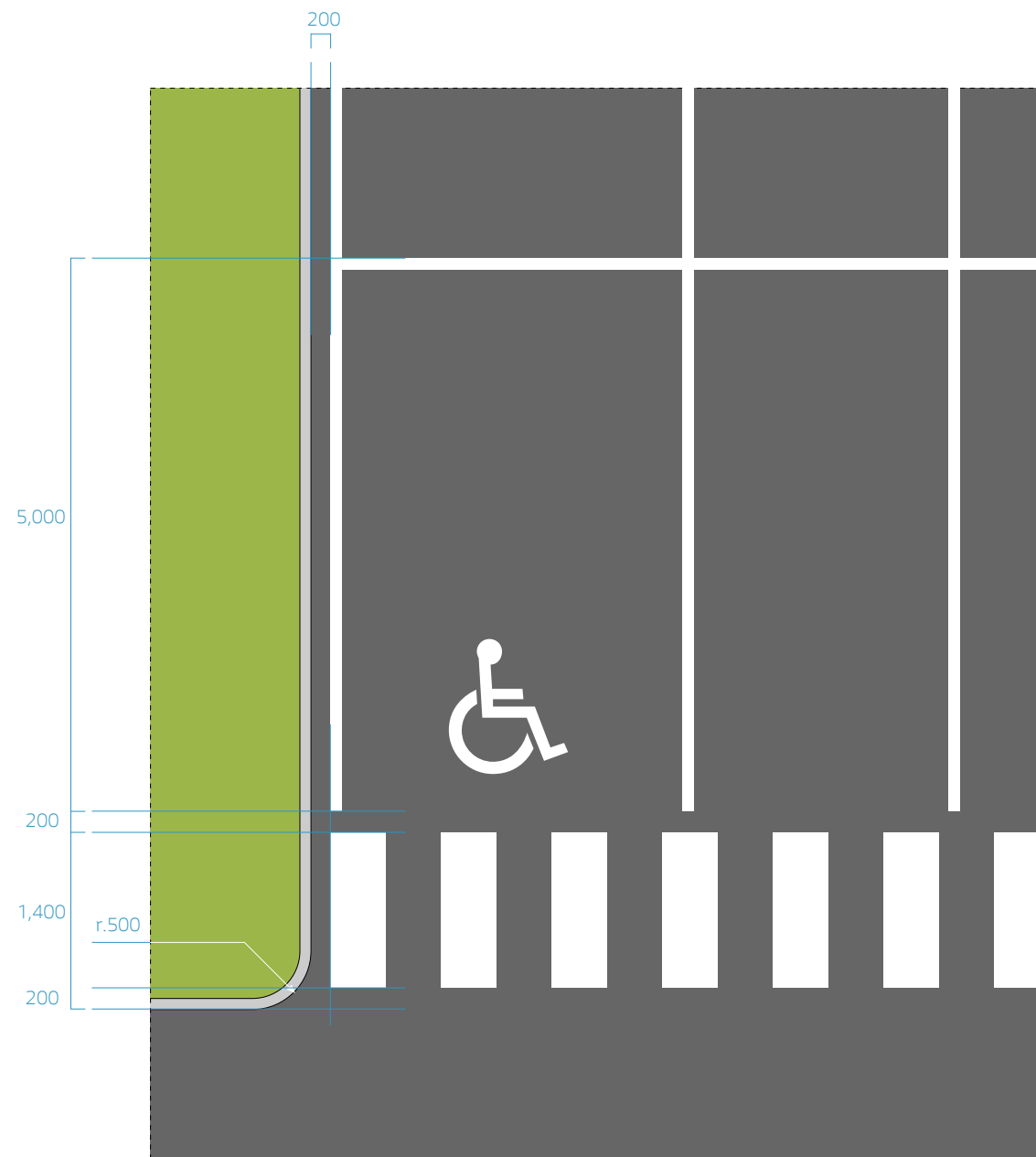

## pedestrian routes presentation

### Purpose

Regulations require pedestrian routes to be marked out within the vehicle traffic areas.

The pedestrian routes link the customer parking areas to the reception points (showroom and after-sales).

We will take advantage of this provision to have customer walk by the vehicles on display.



pedestrian routes

## basic layout

### Regulatory dimensions

Pedestrian walkways shall be marked out with RAL 9003 matt white markings.

- ① Rectangular bands, 500 x 1,400 mm in size, are spaced 500 mm apart.
- ② A square of 1,400 x 1,400 mm shall be used for 90° changes of direction.

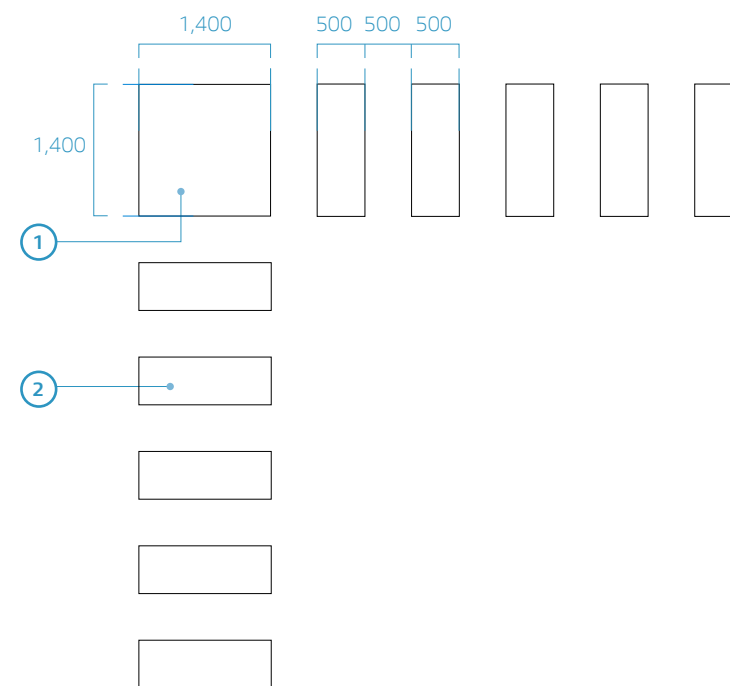
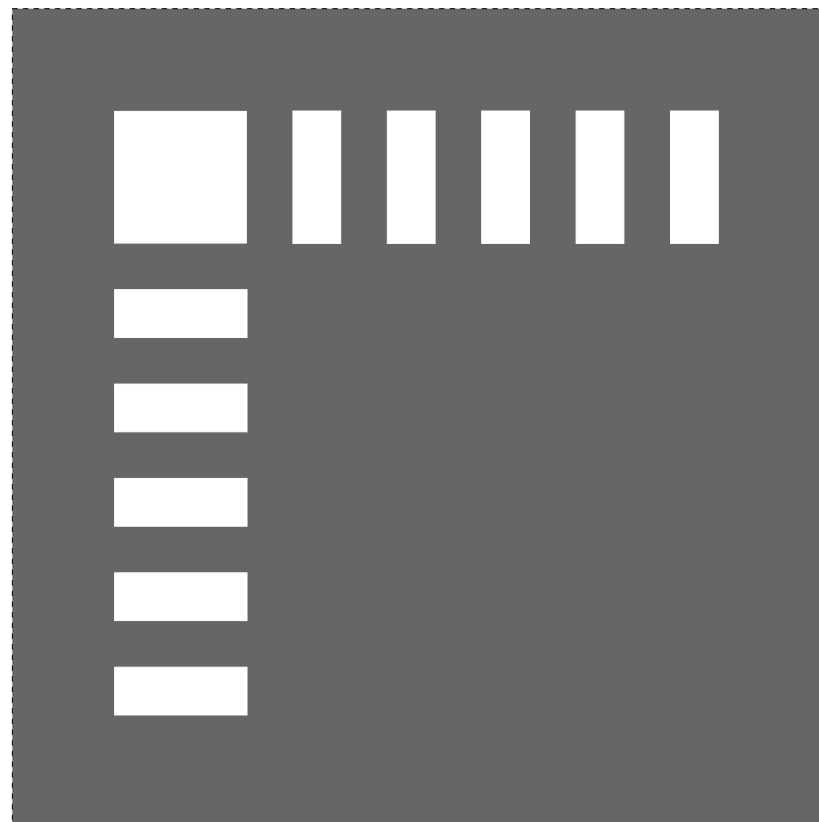

## customer parking areas

### basic principles

#### ① Punctuate the sales customer's journey towards the showroom

The pedestrian route connects the customer parking area to the showroom entrance via the outdoor display areas.

#### ② Punctuate the after-sales customer's journey towards the after-sales reception

The reception point for After-Sales customers shall be located inside the Renault Store showroom.

#### ③ Strongly discouraged

For reasons of safety, it is strongly advised not to have customers walk past the workshop bay doors.

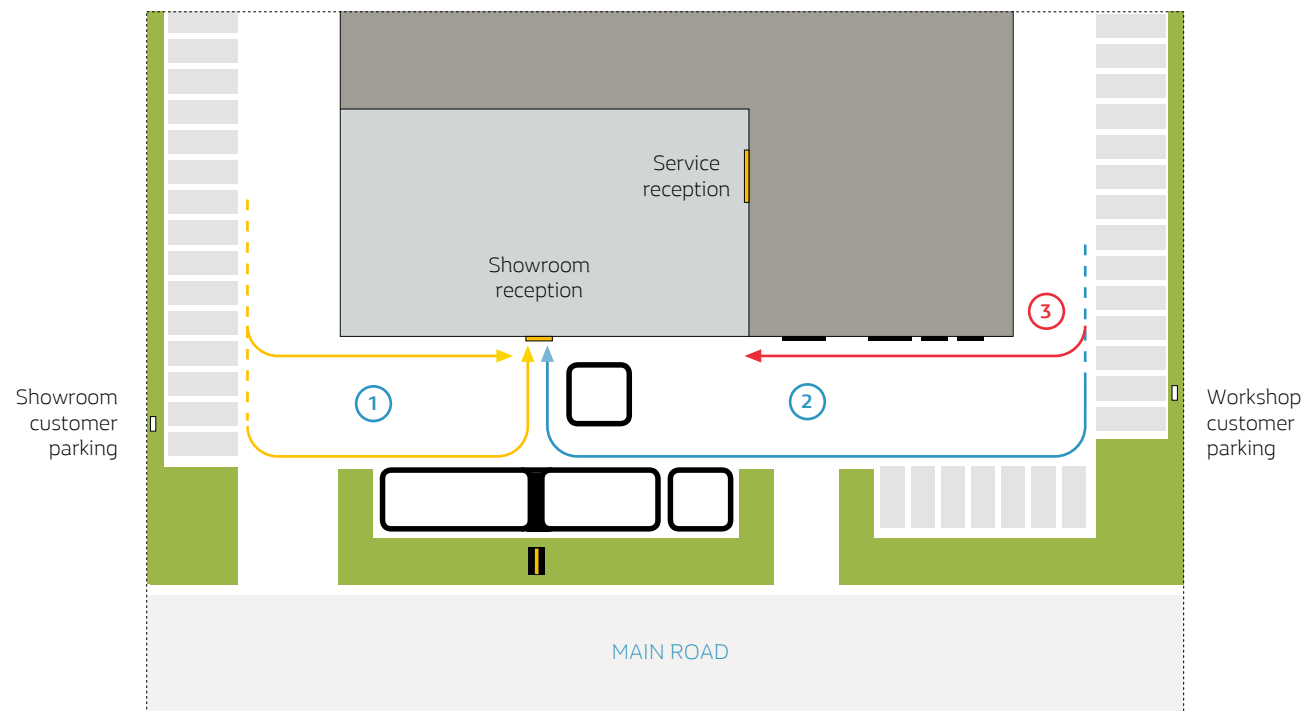



## pedestrian routes display areas

### Basic layouts

- ① A clear space frames the outdoor display zones, contributing to the safety of the pedestrian flows and the showcasing of the vehicles on display.
- ② The pedestrian route passes in front of the display vehicles.
- ③ If necessary, a stabilized path extending from the markings allows pedestrians to cross the clear space.

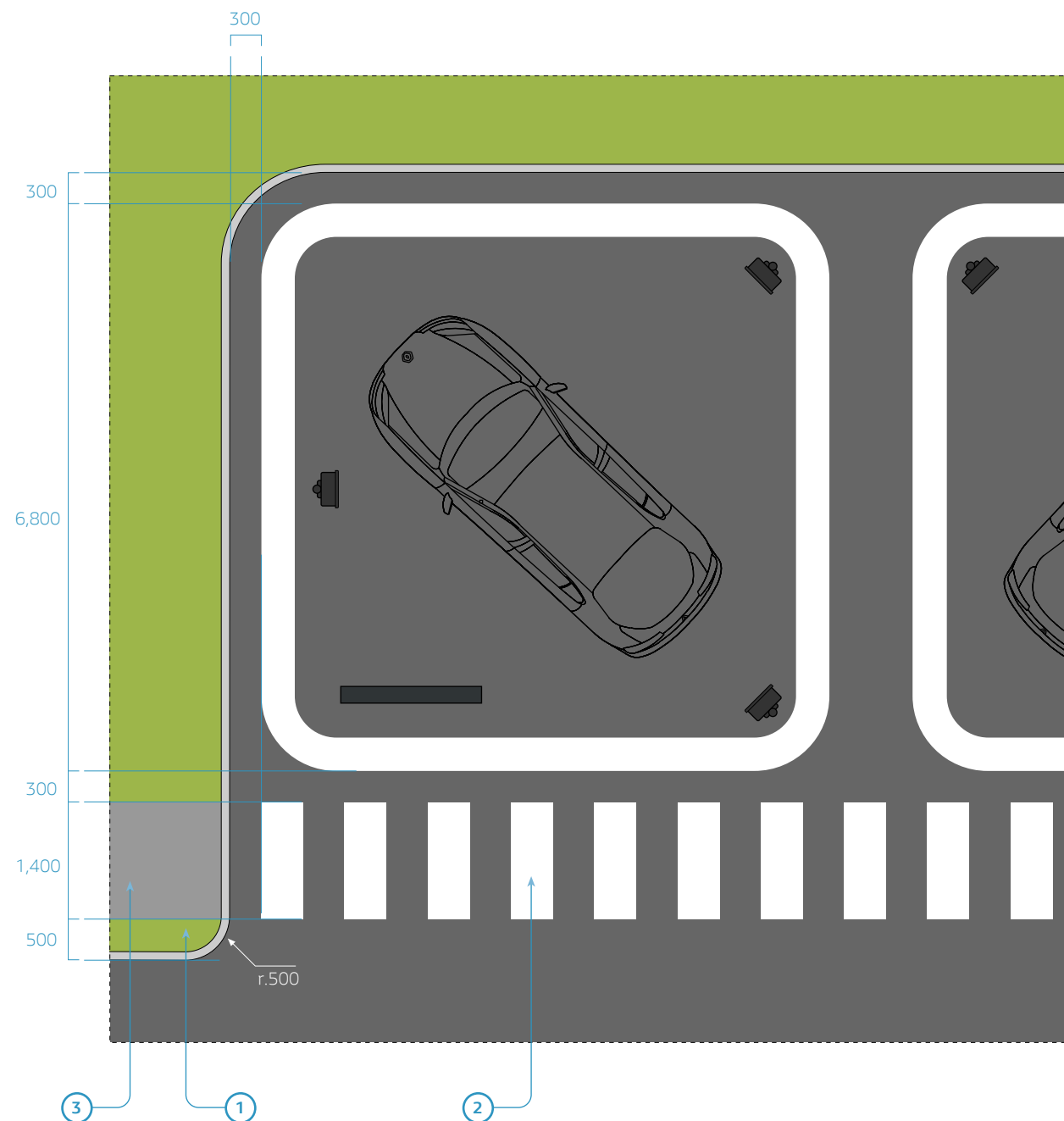

pedestrian routes

## markings to the showroom entrance

### Connecting the display areas to the showroom entrance

- ① A broader pedestrian walkway (3,000 or 3,500 mm depending on the width of the canopy) interconnects the outdoor display zones and the showroom entrance.
- ② A large rectangle forms the intersection between the pedestrian ways.

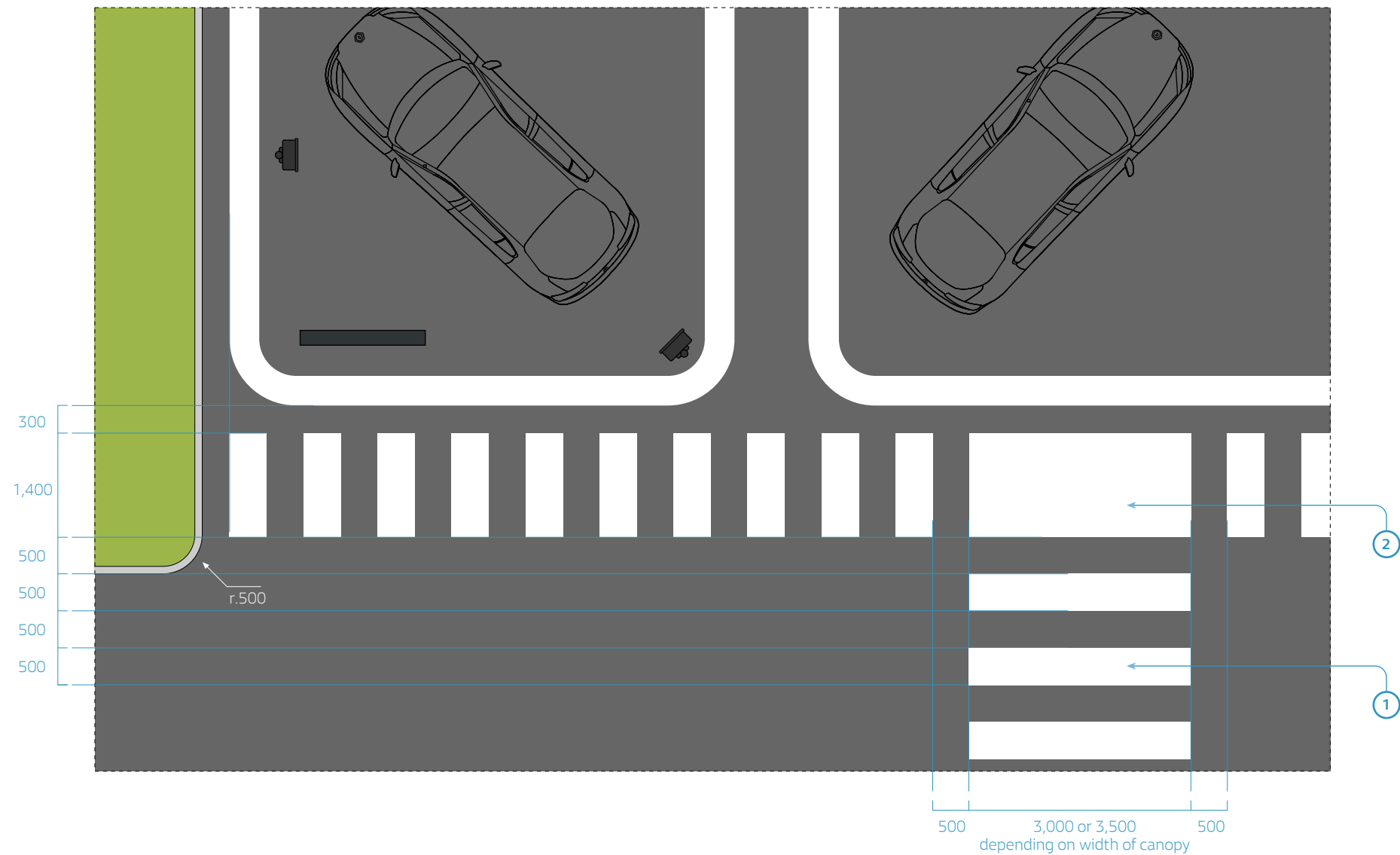

pedestrian routes

## clear area along site frontage - 1

### Accommodate and showcase the Renault totem

- ① The totem bearing the Renault brand emblem is located directly in line with the showroom entrance.
- ② A clear space with a minimum width of 2 m ends also frames the totem and provides a transition with the public domain.
- ③ The pedestrian way, totem and showroom entrance should be aligned regardless of how the different display zones are arranged.

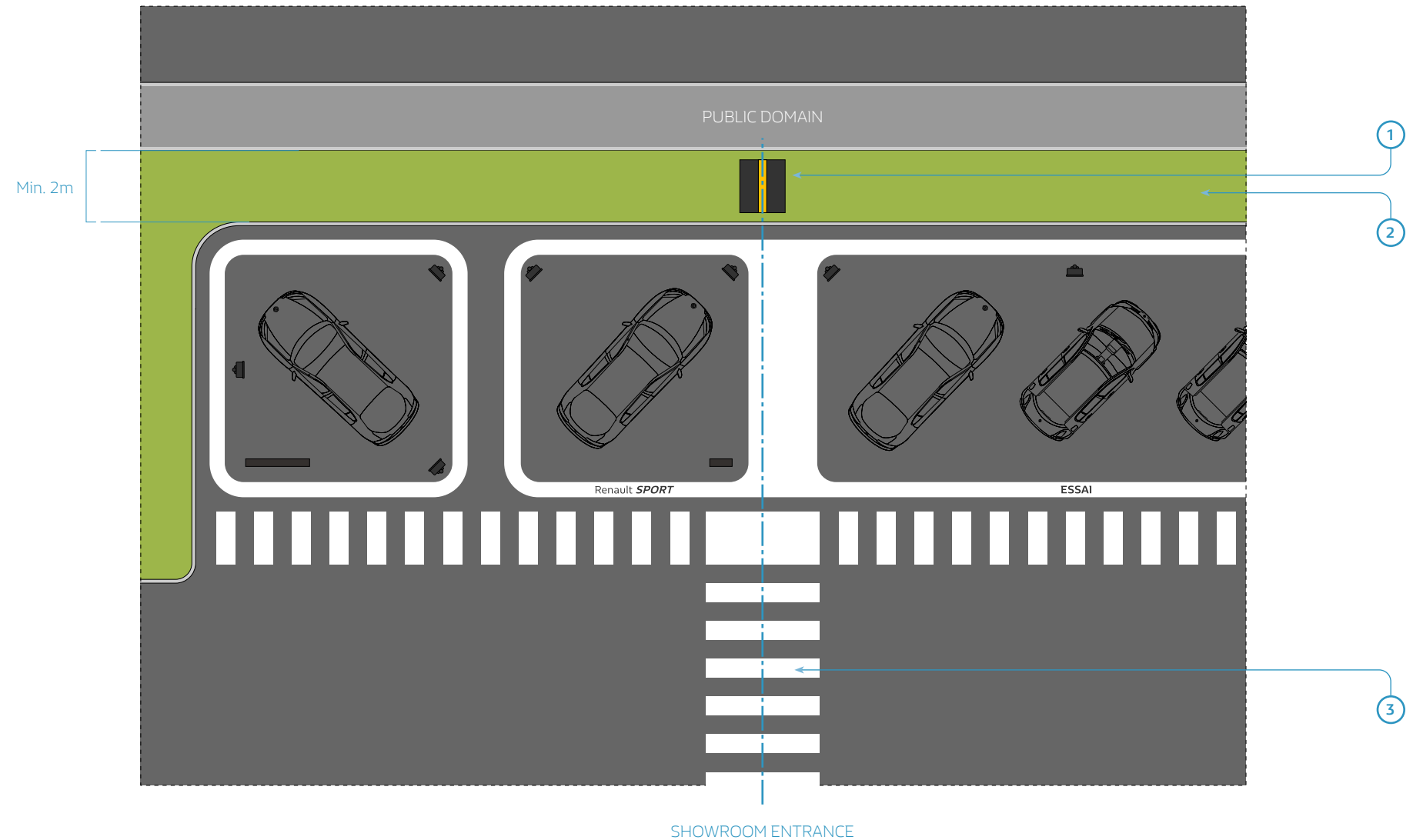

pedestrian routes

## clear area along site frontage - 2

### Create a central clear space for the totem

- ① When the clear space along the frontage is less than 2 m in width, a central clear space between the display zones must be created for the totem.
- ② The front of the totem shall be aligned with the inner edge of the peripheral clear space and centred relative to the entrance.
- ③ A display zone may be split into two parts to allow the insertion of this central clear space (test drive zone illustrated).

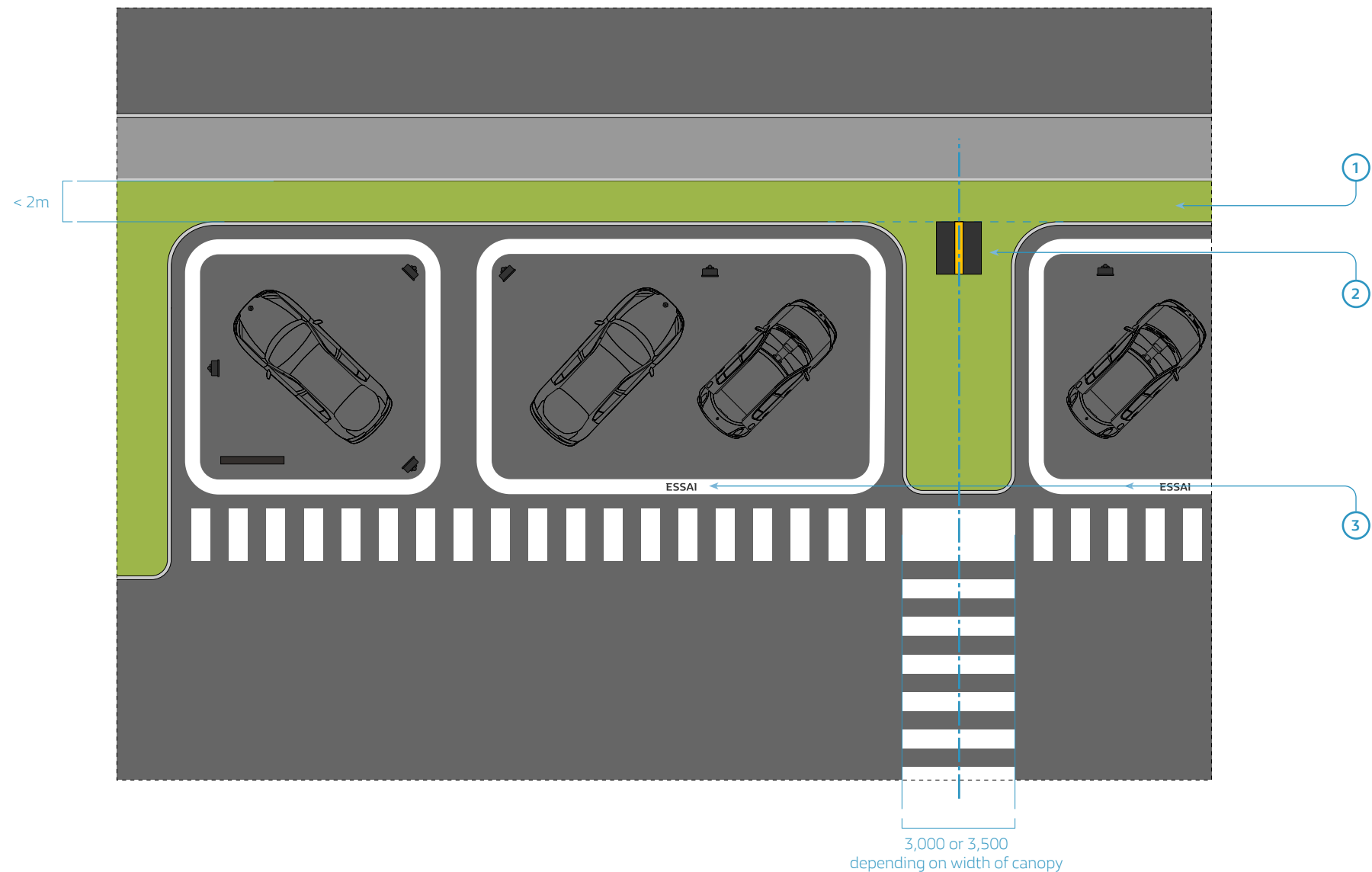

pedestrian routes

## clear area along site frontage - 3

### Create a central clear space to accentuate the visibility of the entrance

- ① To further mark the entrance of the showroom, it is possible to extend the front clear space between 2 display zones.
- ② The Renault totem is located in line with the showroom entrance.
- ③ The width of the central clear space is made to match that of the pedestrian corridor.
- ④ The pedestrian way, the totem and the showroom entrance are aligned.

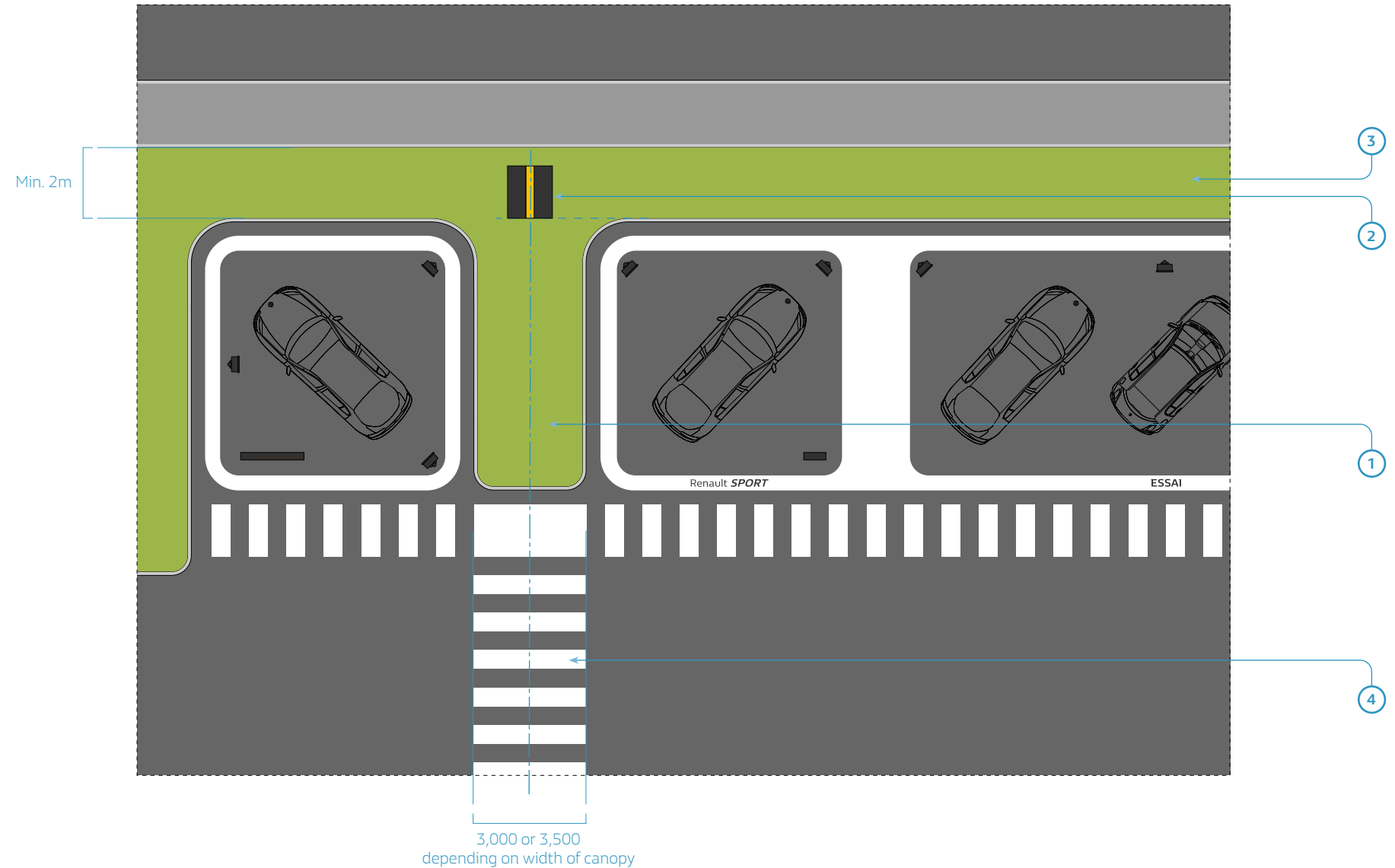

pedestrian routes

## clear area along site frontage - 4

### Linking the public domain to the showroom

- ① Depending on the urban environment of the site, it may be useful to provide a pedestrian route onto the site from the public domain.
- ② A pedestrian way may be located between 2 display zones connected to the public domain via a strip of stabilized path crossing the peripheral clear space.
- ③ This protected walkway joins the pedestrian route running along the outdoor display zones areas.

### Note

Avoid extending the pedestrian way in line with the showroom entrance so as not to have to offset the totem.

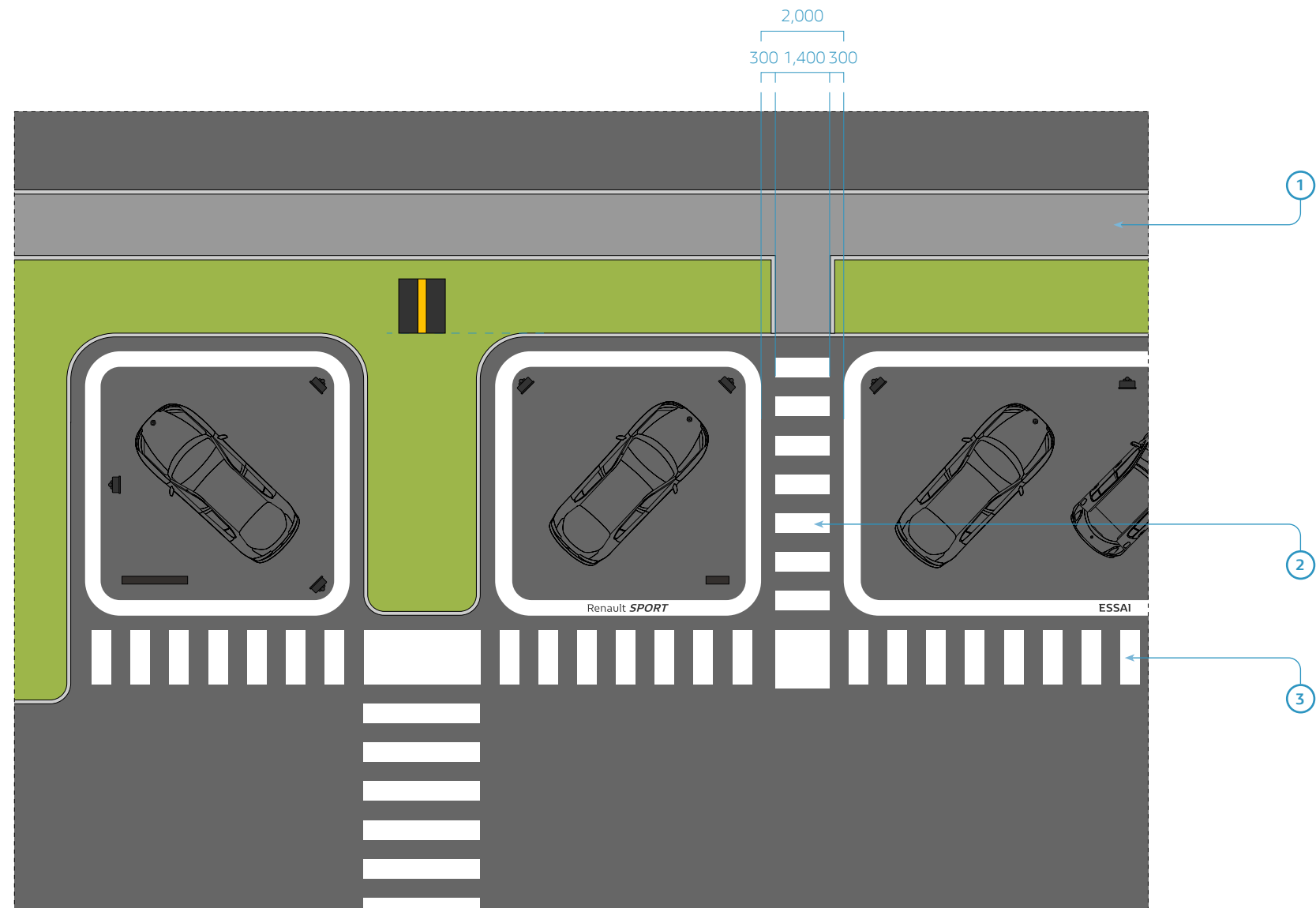

## pedestrian routes the forecourt

### General recommendation

- ① Framed by a clear space, the outdoor display zones are located in front of the showroom.
- ② The pedestrian route passes in front of the display.
- ③ A pedestrian walkway with the same width as the canopy interconnects the outdoor displays and the showroom entrance.
- ④ A white line materializes the edge of the traffic lane for vehicles.
- ⑤ Concrete or steel posts shall be installed as a security element in the area, preventing any risk of vehicle contact with the showroom window and allowing pedestrians to move safely.
- ⑥ The canopy floor markings continue outside of the showroom in the form of a painted decor.

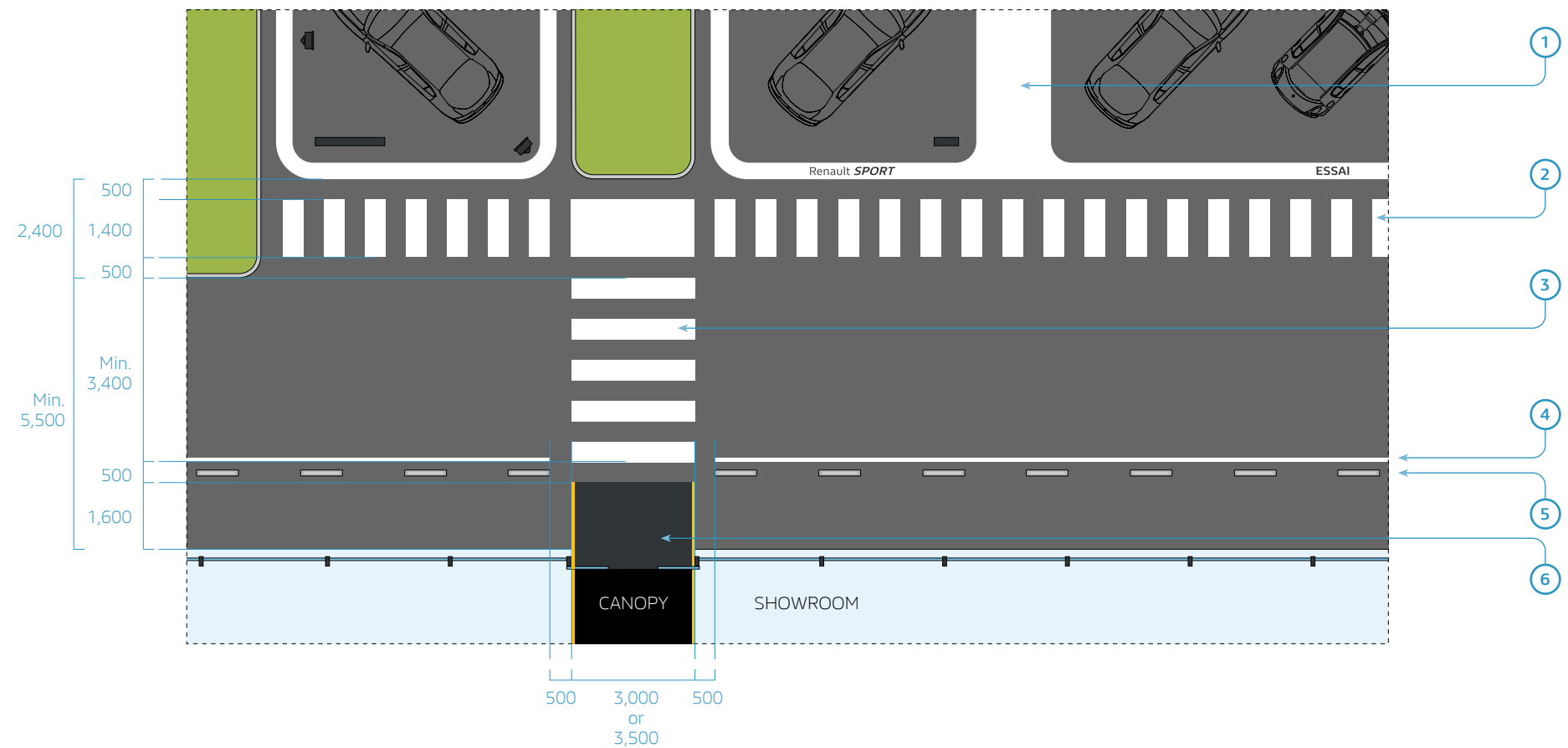

pedestrian routes

## minimal length of the forecourt

### When the available façade space is limited...

- ① A clear space frames the outdoor display zones, contributing to the showcasing of the vehicles on display.
- ② A pedestrian walkway interconnects the outdoor displays and the showroom entrance.
- ③ A white line delimits the traffic lane in front of the showroom façade.
- ④ Concrete or steel posts shall be installed as a security element to prevent any risk of contact with the showroom window.
- ⑤ The canopy floor markings continue outside of the showroom in the form of a painted decor.

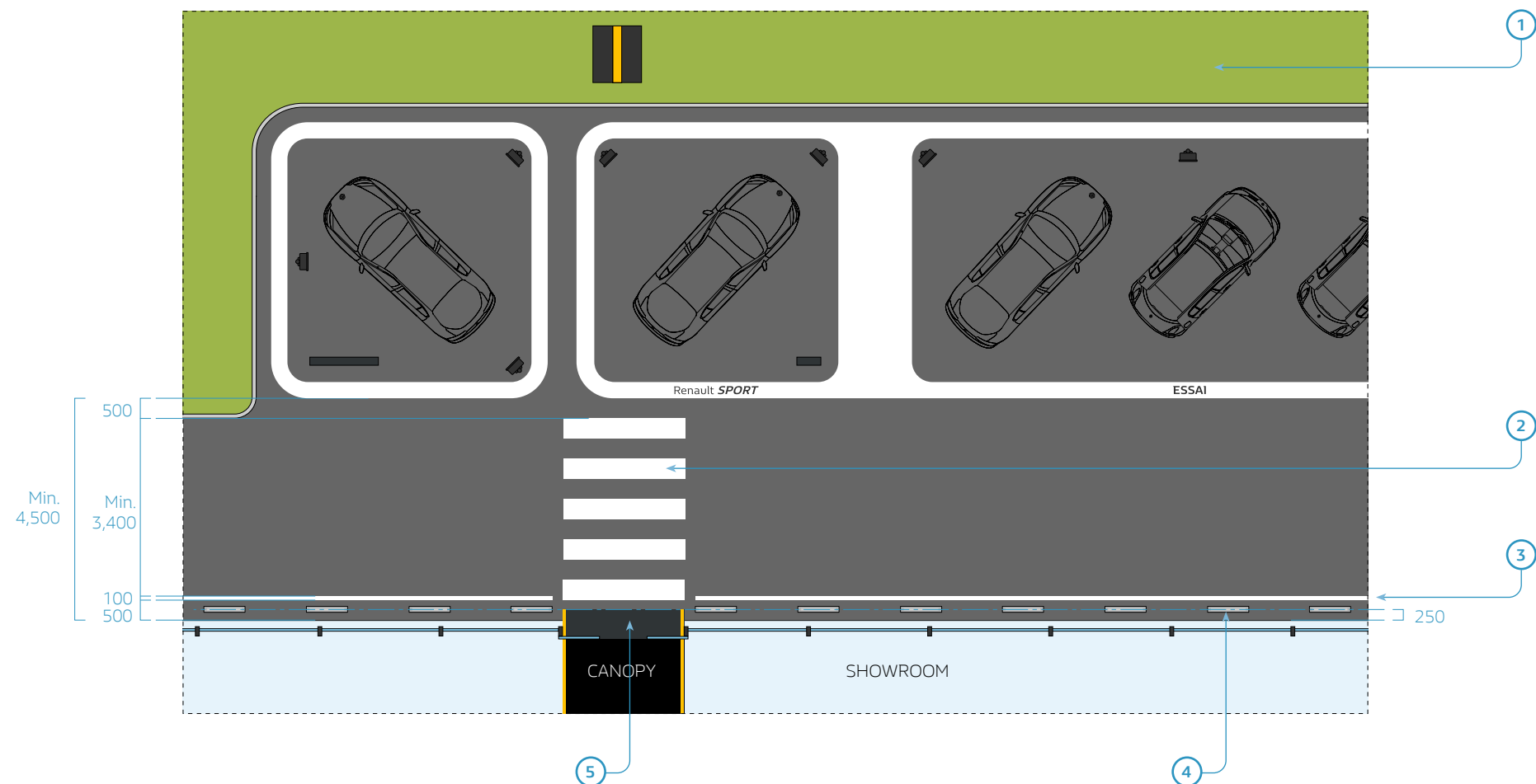



pedestrian routes

## display zones on 2 rows on the forecourt

### Possibility for densifying outdoor displays

- ① The display zones are arranged as close as possible to the main traffic lane.
- ② A pedestrian walkway interconnects the outdoor displays and the showroom entrance.
- ③ The Renault ZE display zone is located next the showroom creating a second row of display vehicles. Vehicle traffic flow is between these 2 rows.
- ④ PRM spaces are located near the entrance of the showroom in counterpoint to the Renault ZE zone.

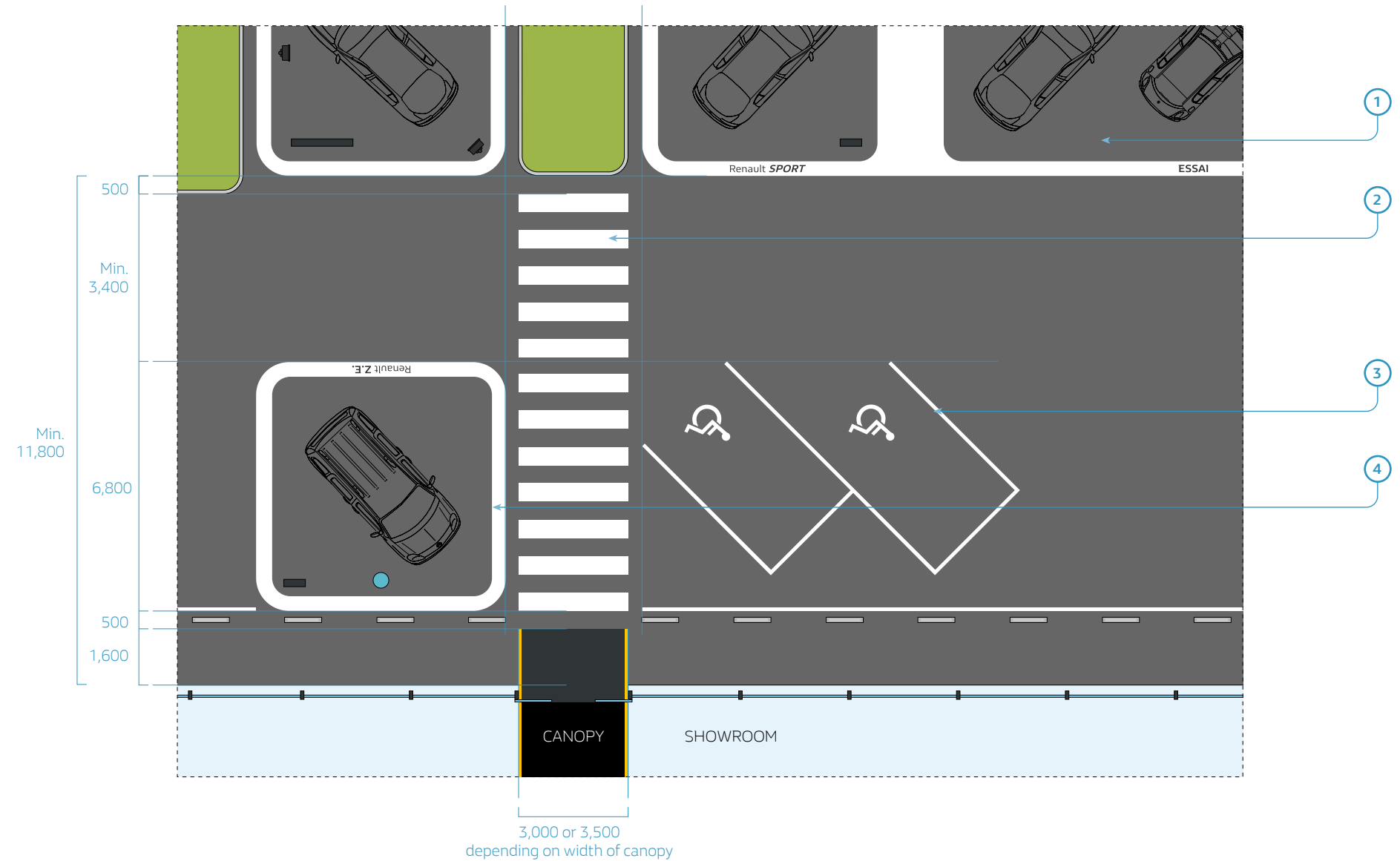

pedestrian routes

## from the showroom customer parking area

### A protected walkway connects to the customer parking area

- ① Pedestrian traffic in front of the showroom is secured by concrete or steel posts. This is continued on the secondary façade of the showroom if necessary.
- ② A pedestrian walkway interconnects the customer parking area and the showroom entrance.
- ③ The parking sign is positioned a minimum of 500 mm from the edge of the clear space to prevent any risk of contact with vehicles
- ④ The clear space against which the customer parking area is set must have a minimum width of 1,000 mm to accommodate the parking signs.
- ⑤ The Exit sign is offset by 500 mm from the edge of the clear space to prevent any risk of contact with vehicles.

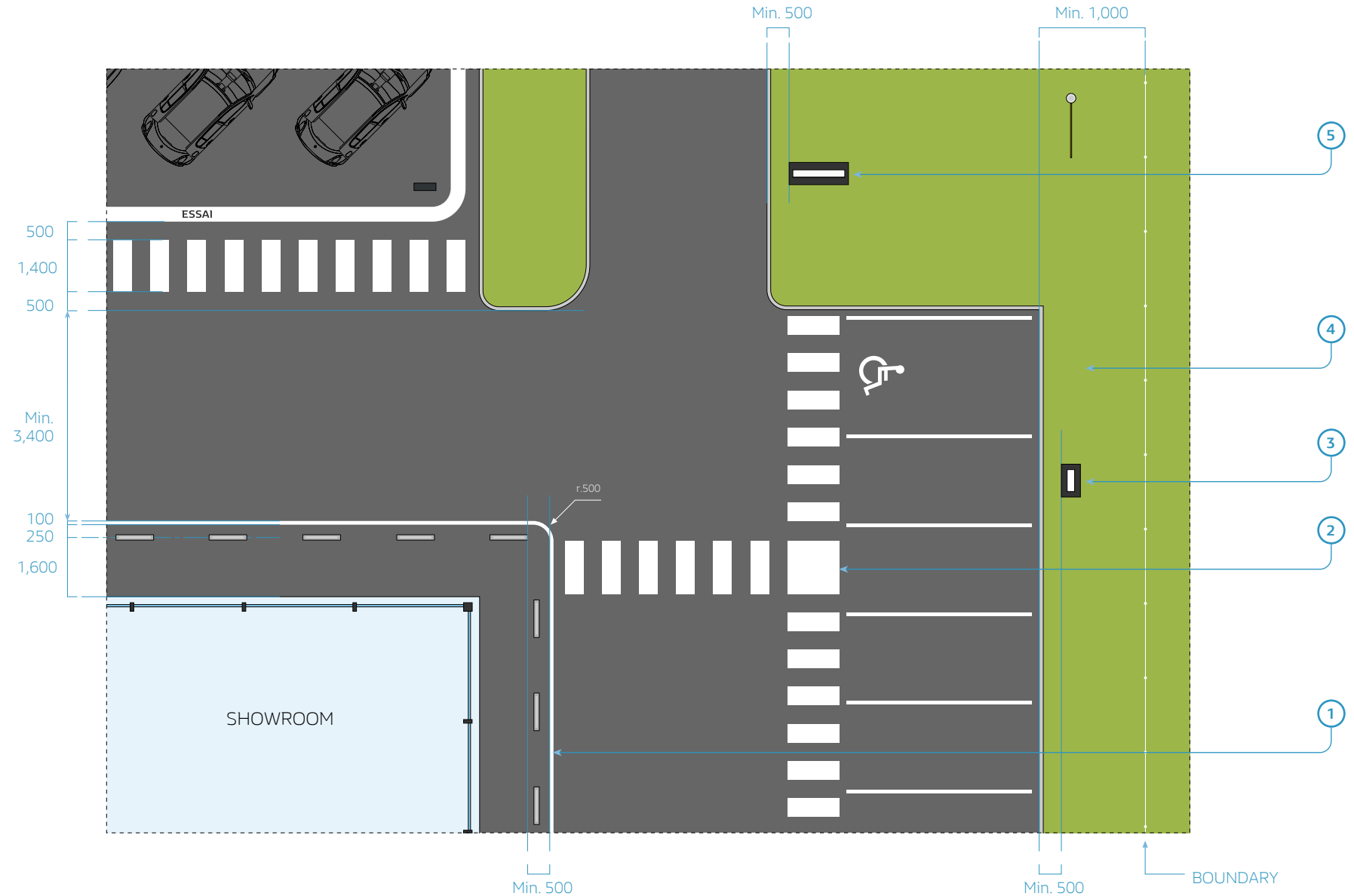

pedestrian routes

## from the workshop customer parking area

### The pedestrian route leads up to the Service Reception

- ① A pedestrian walkway interconnects the After-Sales customer parking area and the entrance of the Renault Store showroom in which the Service Reception is located.
- ② The after-sales customer passes in front of the outdoor display zones before reaching the showroom.
- ③ Pedestrian traffic in front of the showroom is interrupted at the workshop entrance doors.
- ④ The corner of the building is protected by concrete or steel posts associated with a white line delimiting the vehicle traffic lane.

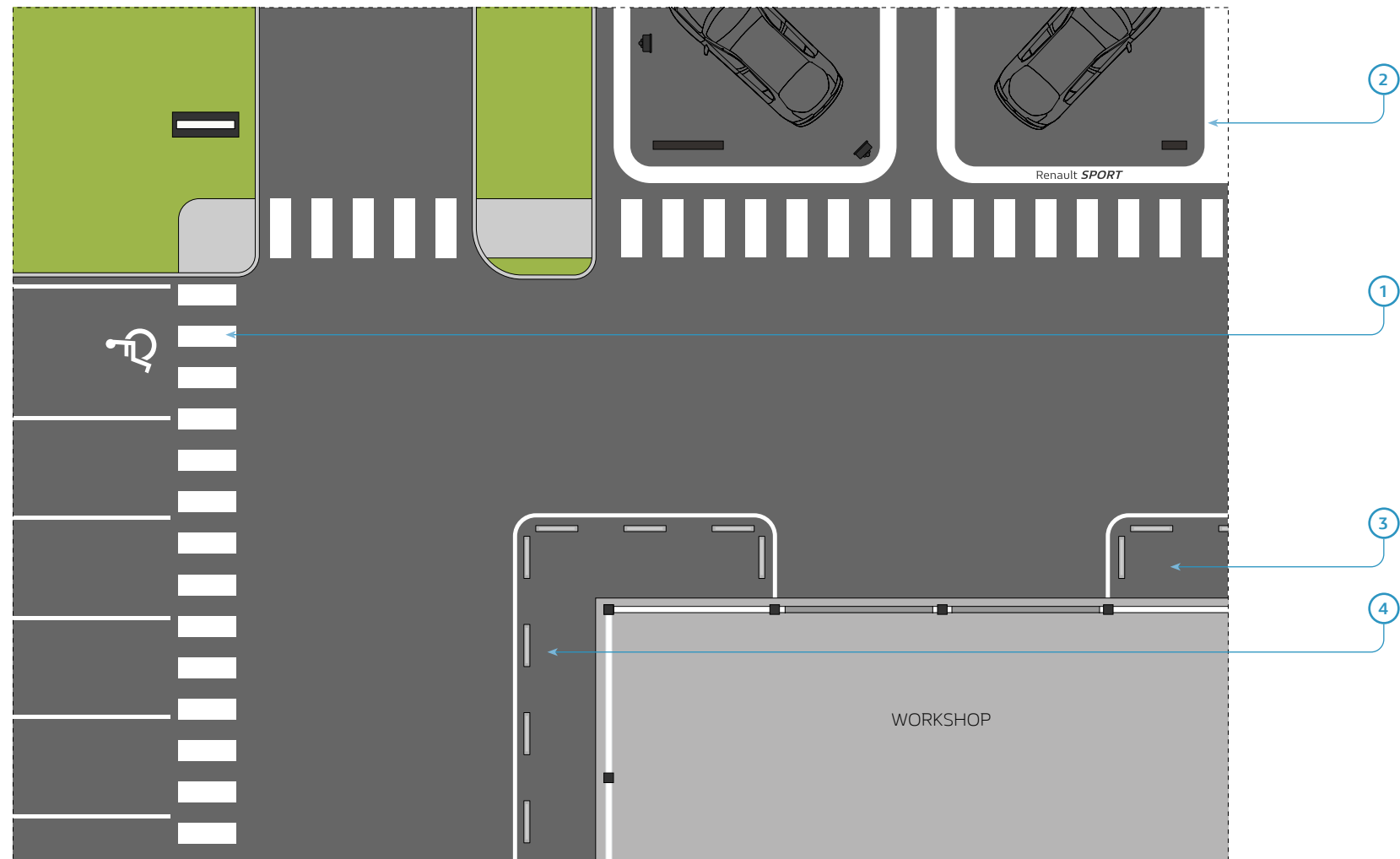

pedestrian routes

## posts and edging

### Alternative standard items

These elements are to be chosen from catalogues of standard products offered by local suppliers of urban furniture and fixtures.

- ① The anti-intrusion concrete edging pieces are inexpensive items. Anchored to the ground, they protect pedestrians and buildings whilst remaining discrete in appearance.
- ② The posts are of 2 types:
  - low, round anti-intrusion posts for the protection of traffic and buildings.
  - high, round anti-intrusion posts for the protection of pedestrians, reserved for intersections between traffic lanes and protected walkways.

These posts present little visibility for drivers and must be placed in locations that do not require maneuvering.

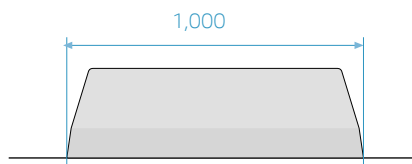

PEDESTRIAN PROTECTION

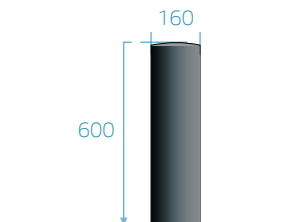

ANTI-INTRUSION

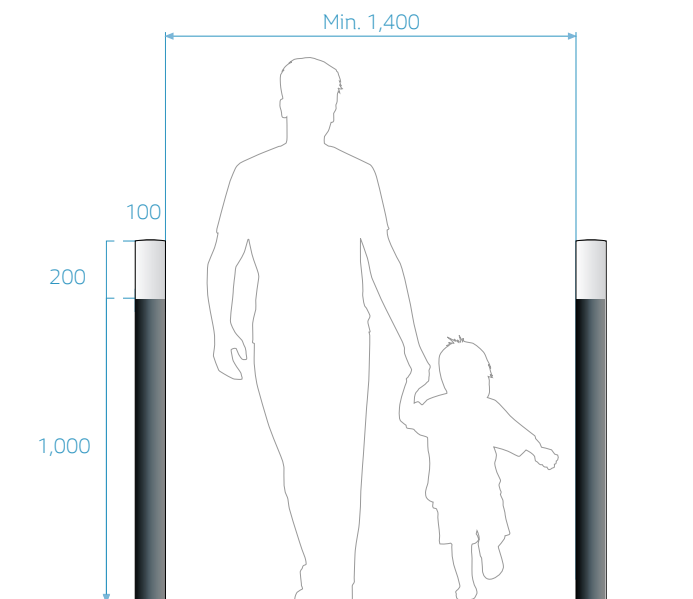
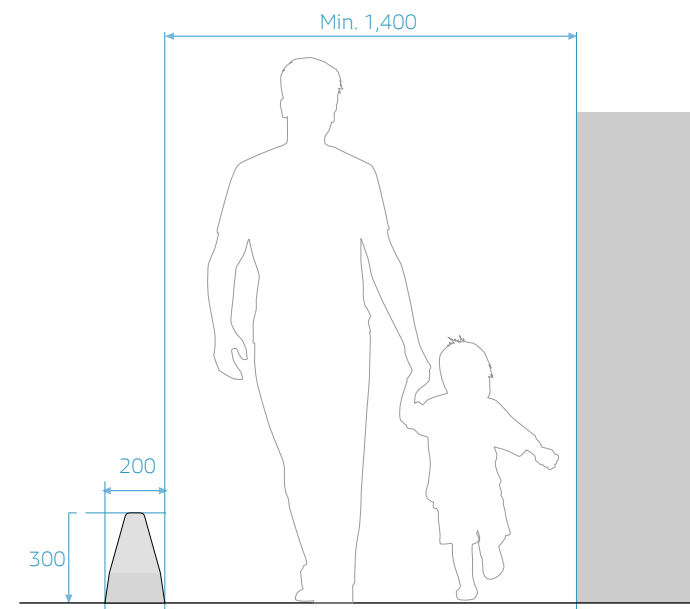

PEDESTRIAN PROTECTION

## lighting of the site presentation

### Purpose

The lighting of the site and its approaches is an significant factor in the site's attractiveness.

It gives life to the site in the night time.

The lighting showcases vehicles on display and accompanies customers as they move around the site.

It helps to connect the different spaces together in night situations.



## lighting of the site

### general layout

#### The recommendations

- ① Illuminated bollards are distributed along the directions of movement and close to the parking areas to make it more comfortable for customers to move around the site.
- ② The display areas is lit with spotlights mounted on masts. These elements are described on page 5.7.
- ③ The residual light from the showroom showcases the forecourt, naturally guiding the customer to the entrance.
- ④ The 4x3 promotional sign may be illuminated creating a strong visual appeal.



lighting of the site

## the illuminated bollards

### Alternative standard items

These elements are to be chosen from catalogues of standard products offered by local suppliers of urban furniture and fixtures.

The characteristics to be observed are the following:

- Cylindrical aluminium bollard, equipped with a diffuser protected by a grille concealing the LEDs.
- Warm white lighting: 3,000°K.
- 15 watts power for a luminous flux of 500 to 600 lumens.
- Polycarbonate diffuser surrounded with a grille with a minimum IP54 protection rating.
- Anchor bolt mounting.
- RAL 7021 dark grey satin finish.

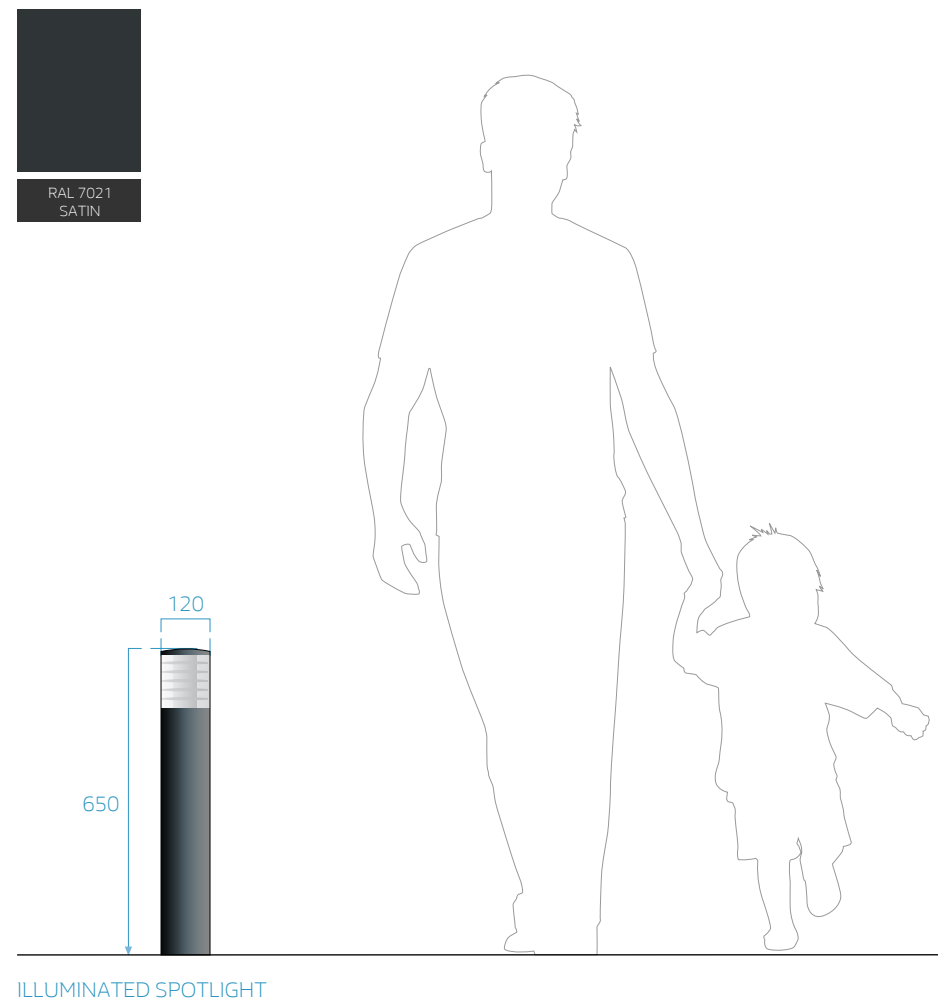

EXAMPLE 1. D-CO by Thorn Europhane



EXAMPLE 2. LUCIUS

## landscaping of the site

# introduction

### Purpose

Landscaping enhances the site by better integrating it into the environment and framing the views offered to customers.





## landscaping of the site

### general design

#### The recommendations

- ① The exterior display areas are enhanced by low-level borders (h < 150 mm).
- ② Customers parking areas are partially masked by the implementation of mid-level borders (h < 400 to 1,000 mm).
- ③ The signage items (totem, directional sign and parking sign) must be contextualized by the application of a mineral design around the periphery of the object.
- ④ The periphery of the site may be protected and masked by the use of fences set with trees (h = 2,000 to 4,000 mm) subject to not masking signage items.



## landscaping of the site

### integration of totem

#### Purpose

The use of mineral zones avoids any possible damage that may be caused by lawn mowers or edgers, while conferring a special status by creating a clear space around the item.

#### Recommendation

The concrete block may be recessed to accommodate a finish treatment around the totem:

- ① either with black pebble,
- ② or an asphalt finish.

The planted element shall be low-level:

- ③ either lawn,
- ④ or ground ivy that has the advantage of requiring only minimal maintenance.

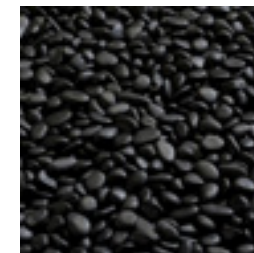
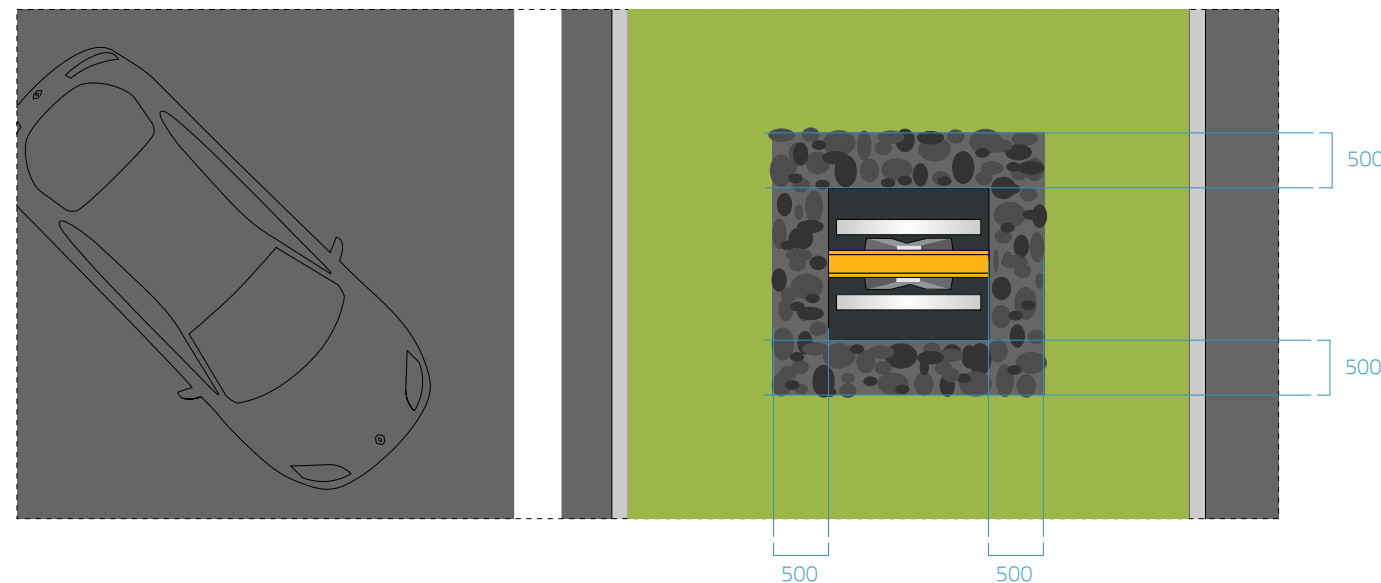

①



②

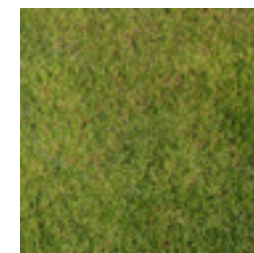

③

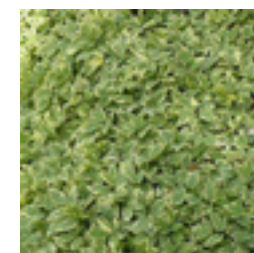

④

landscaping of the site

## integration of the directional sign

### Purpose

The use of mineral zones avoids any possible damage that may be caused by lawn mowers or edgers, while conferring a special status by creating a clear space around the item.

### Recommendation

The concrete block may be recessed to accommodate a finish treatment around the directional sign:

- ① either with black pebble,
- ② or an asphalt finish.

The planted element shall be low-level:

- ③ either lawn,
- ④ or ground ivy that has the advantage of requiring only minimal maintenance.

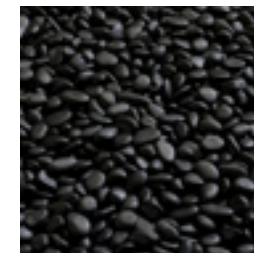
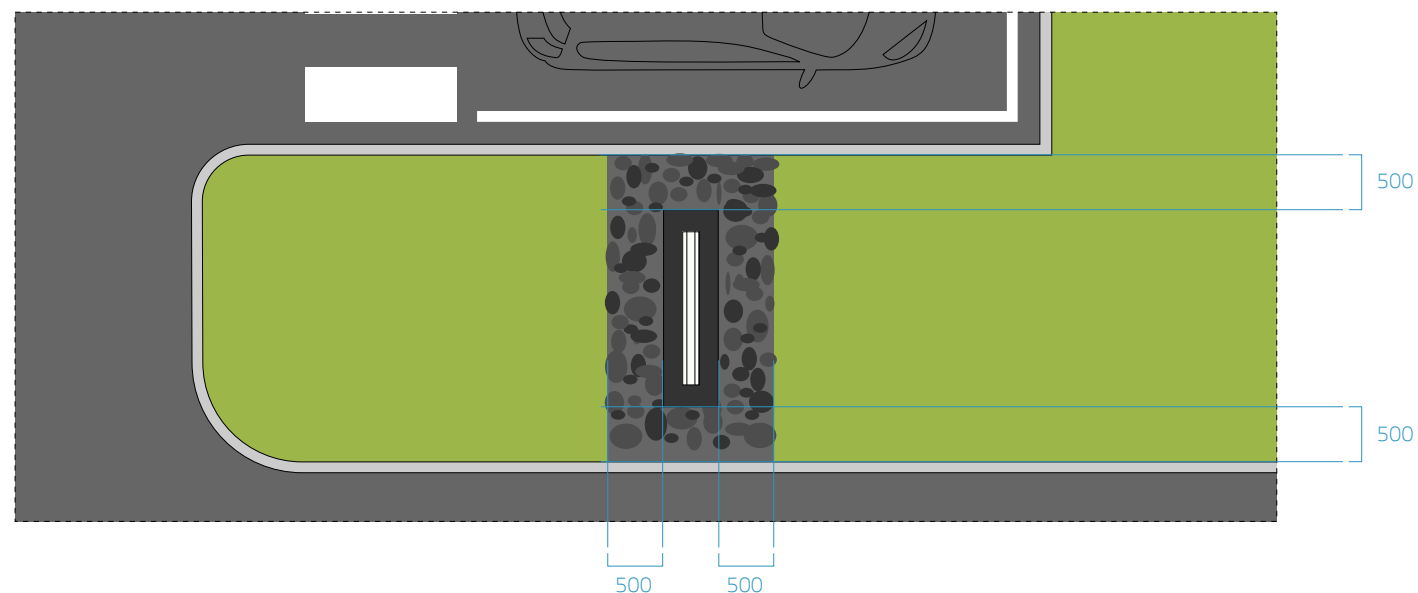
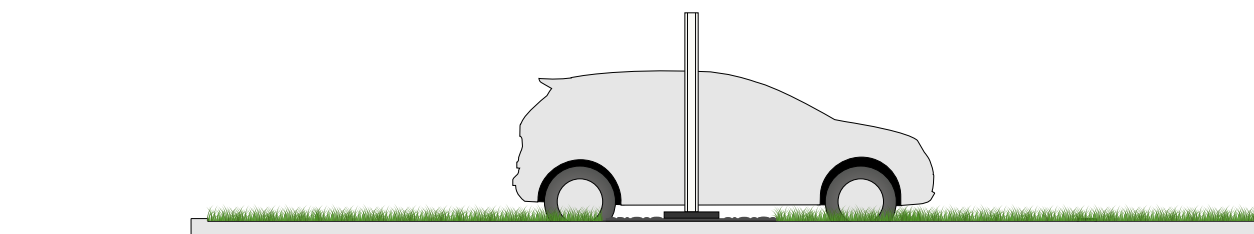

①



②

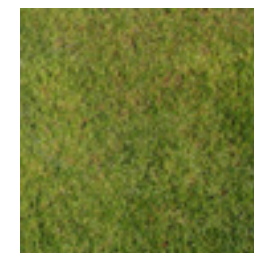

③

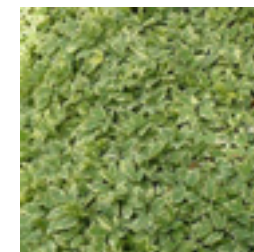

④

Note. The choice of species is made according to site constraints (authorized species - climate constraints)

## landscaping of the site

# integration of the parking sign

### Purpose

The use of mineral zones avoids any possible damage that may be caused by lawn mowers or edgers, while conferring a special status by creating a clear space around the item.

### Recommendation

The concrete block may be recessed to accommodate a finish treatment:

- ① either black pebble,
- ② or asphalt.

The recommended landscaping aims to partially mask the parked cars with mid-height shrubs ( $h < 1\text{ m}$ ), such as for example:

- ③ Hypericum Hidcote,
- ④ Ruscus Bamboo.

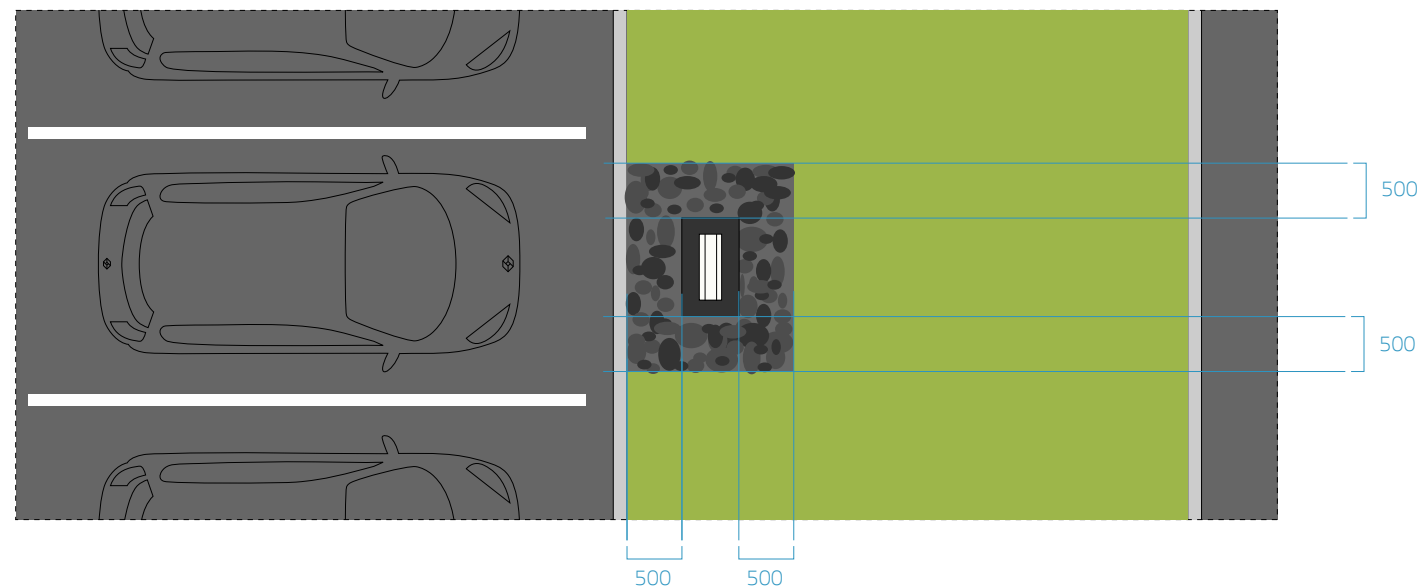
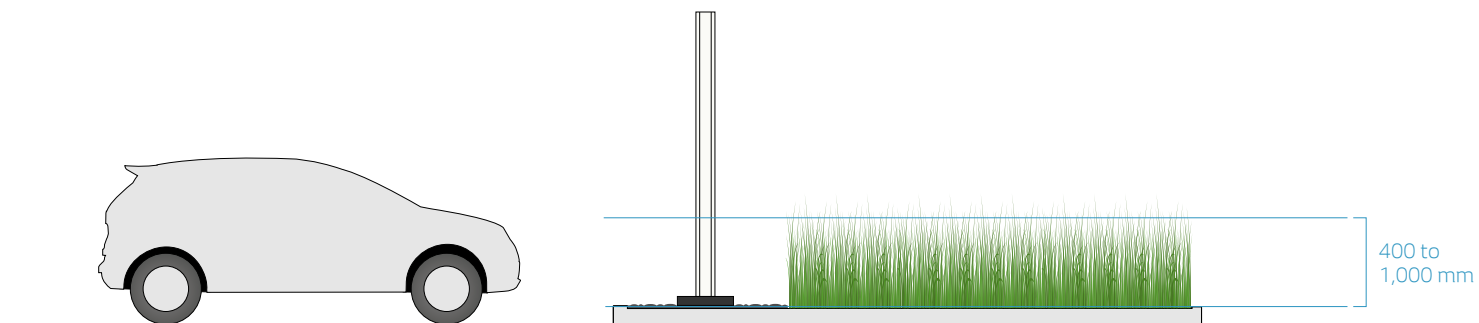

①



②

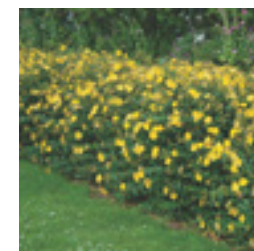

③



④

# landscaping of the site

## fencing

### Purpose

The landscaping element is designed to enhance the approaches to the site or to mask neighbouring plots and to delineate the property.

### Recommendation

- ① A fence may be installed and fabricated from thermo-lacquered dark gray RAL 7021 metal mesh panels 2 m in height.
- ② It may be partially planted to a height of 1 to 1.5 m.
- ③ Stem trees may also be used to make the planted screen effect more effective.

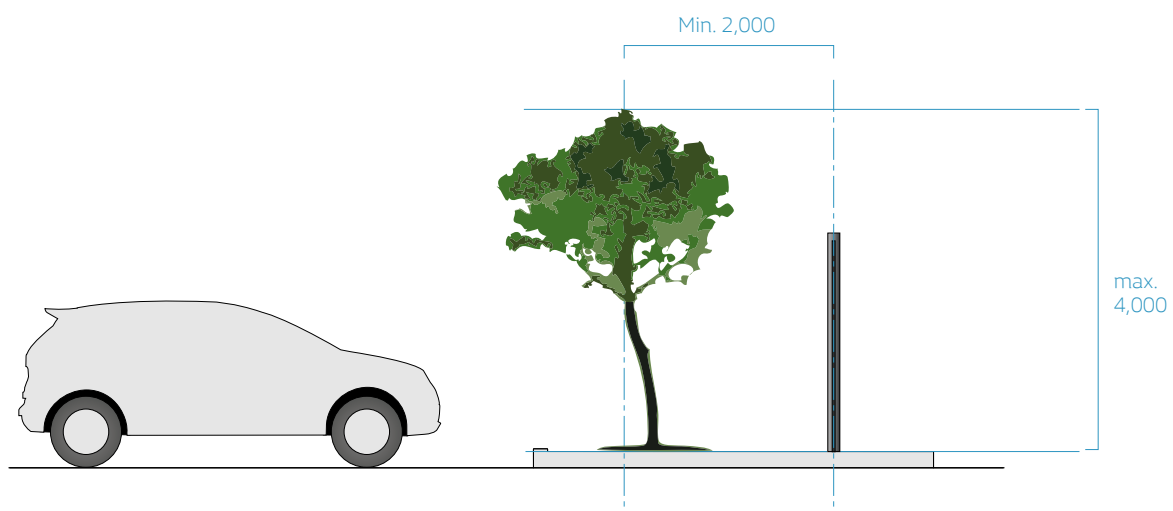
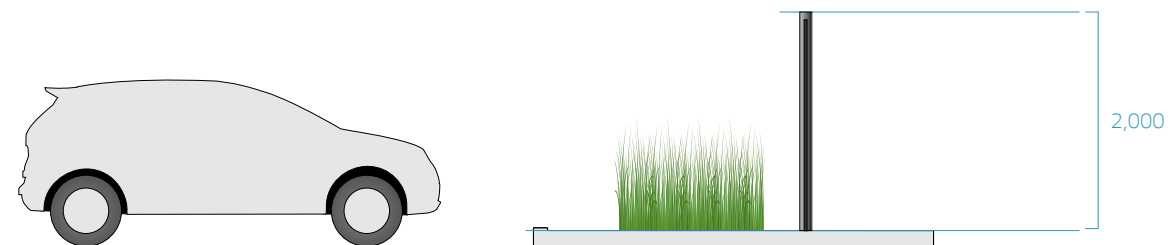

①



②



③

## landscaping of the site

# walls and barriers

### Purpose

The landscaping element is designed to enhance the approaches to the site or to mask neighbouring plots and to delineate the property.

### Recommendation

- ① The walls along the site periphery shall be painted white RAL 9010.
- ② They can be accompanied and partially masked by trees around 4m in height.
- ③ The metal barriers shall be thermo-lacquered dark gray RAL 7021.

