

Renault
Group

renew sites
Guidelines

Edition 1b • January 2024



Introduction

The different renew formats

In the form of a renew outdoor exhibition, used vehicles are integrated into Renault sites by offering consistent customer journeys.

Inside a building, within or adjacent to the new vehicle showroom, the renew showroom offers a highlight of flagship products and an organization by segments of renew offers for greater commercial efficiency.

The independent sites concentrate on an independent site outdoor and indoor exhibitions devoted solely to the used vehicle trade.

How to size renew exhibitions?

The recommended number of vehicles exhibited (in the form of exterior and/or interior exhibition) must be close to a ratio of 1/10th of the annual volume of sales of used vehicles to private customers made by the dealer.

For example, a dealer making 100 sales to individuals should have a minimum of 10 used vehicles on display at all times (in total of used vehicle display sites).

Renew corners of multi-label sites

Outside the Renault network, the presence of a renew exhibition in a multi-label showroom is also offered.

Contents

1	Generalities	4
2	The integrated exhibition and corner	8
3	The integrated showroom and exhibition	19
4	The independent site	34
5	Exterior components	41
6	Interior components	57
7	The renew corner in a multi-label site	74

1

GENERALITIES

1.1 Documents

WHY?

Help each user find or discover the rules and standards to apply when implementing a renew site.

HOW?

- The renew sites guidelines present in a single document the different configurations of renew sites and the components used.
- The renew integrated showroom retrofit guide presents the methods for retrofitting existing sites
- The renew signage specifications present all the technical and aesthetic requirements useful for the manufacture of signage components.
- Renault specifications describe the Renault components that may potentially be used inside or outside a renew site.

All these documents are available on:
<https://brandstores.renault.com>

Vigilant point

Despite all the care taken in the design of this document, errors or omissions may have been made. If in doubt, contact your Network Development correspondent in the country or Renault Global Marketing.

The visuals are given for information only, the technical specifications remain the reference documents (available in French and English).



renew sites guidelines



retrofit guide for integrated showrooms renew

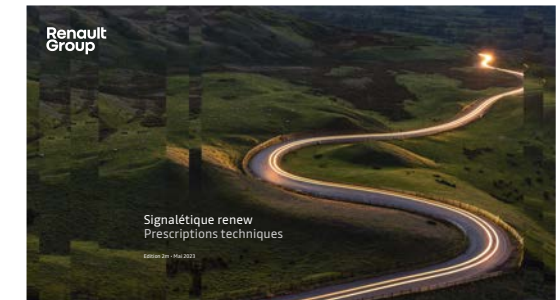

specifications for renew signage



technical specifications for interior components



technical specifications for exterior components

1.2 Les configurations des sites renew

WHY?

renew sites adopt different configurations aimed at presenting the used vehicle offering within the Renault network (the integrated sites) or independently of a point of sale (the independent site)

HOW?

- 1 The renew outdoor exhibition presents used vehicles on an outdoor exhibition area adjoining a new vehicles showroom.
- 2 The integrated renew showroom presents used vehicles in a dedicated part of a new vehicles showroom. Outside, an exhibition dedicated to used vehicles completes the renew offer.
- 3 The independent renew site presents used vehicles in a dedicated building.

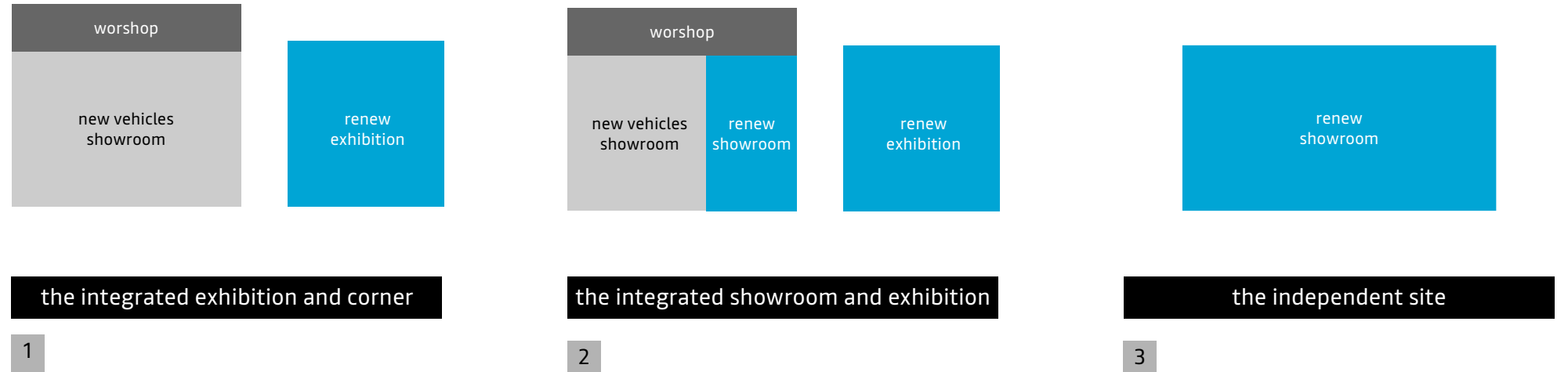

1.3 Components

A FLEXIBLE SYSTEM

In order to provide a consistent customer experience, renew sites include mandatory components.

The optional components make it possible to personalize the offer of each site according to its needs and specificities.

WARNING

This table presents the main lines of use of the different families of components.

Please refer to the detailed description of each of the configurations which are available depending on the number of vehicles present on the site.

Components		the integrated exhibition and corner	the integrated showroom and exhibition	the independent site
facades	Facade pediment cladding	□	□	■
	renew facade marking	□	□	■
	Dedicated entrance	□	■	■
	renew entrance marking	□	■	■
	Customer promise panel	□	■	■
Interior components	Dedicated sales office	■	■	■
	Customer promise panel	■	■	■
	Identification box	□	■	□
	Vehicles displayed in showroom	□	■	■
	Area panels	□	■	■
	renew brand wall	□	■	■
	2x2 POS	■	■	■
Exterior components	renew flagship zone	■	■	■
	Outdoor exhibition area	■	■	■
	renew flags	■	■	■
	Arch or air mast	■	■	■
	renew generic banners	■	■	■
	Markings of exhibition areas	■	■	■
	Lighting poles	■	■	■
	Promotional tarpaulin	■	■	■
	renew sales area	■	■	□

- mandatory
- optional
- not applicable

2

THE INTEGRATED EXHIBITION AND CORNER

2.1 What are we talking about ?

WHY?

The renew outdoor exhibition is integrated into the surroundings of the dealerships, offering a dynamic and rewarding vision of the used vehicle offering.

In addition and optionally, a renew corner can be set up in the new vehicles showroom, presenting a renew car in a thematic area.

HOW?

- 1 The renew outdoor exhibition is located on one side of the site, accessible via protected passages.
- 2 A dedicated customer car park is present near the exhibition offering customers independent access.
- 3 The renew outdoor exhibition area is identified by flags and an arch signage.
- 4 Optionally, a renew corner can be set up in the new vehicles showroom, presenting a renew car in a thematic area.
A renew sales office may also be present in the showroom.
- 5 The renew exhibition can be located either to the right or to the left of the building housing the new vehicles showroom.

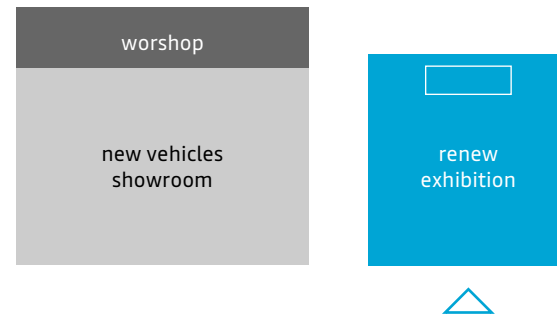

Exhibition location to the right of the showroom

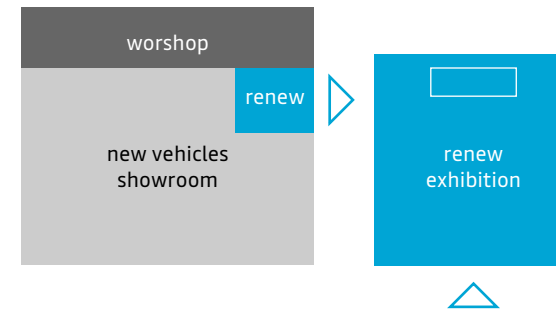

Implementation of a renew corner in the showroom

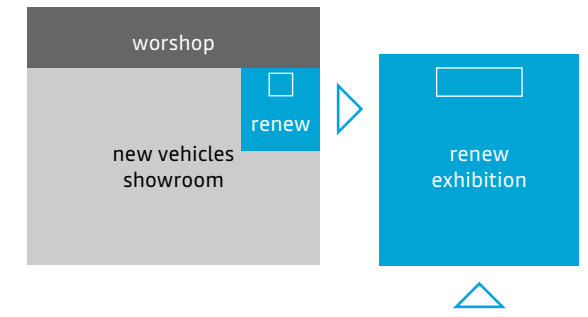

Implementation of a renew corner in the showroom.
Variant with sales office integrated into the showroom.

2.2 General view

WHY?

The renew outdoor exhibition area gives visibility to the used vehicle business.

HOW?

The exhibition area includes an organized set of identification and promotional communication components marking out customer journeys when discovering the vehicles on display.

The central axis highlights vehicles offering a particularly attractive offer.

This axis naturally leads customers to the sales office where they are welcomed by renew advisors.

- 1 Identification signage.
- 2 Central axis.
- 3 renew sales offices.
- 4 renew customer car park.



2.3 Components

WHY?

The outdoor exhibition presents used vehicles in an exhibition area adjoining the showroom.

HOW?

The renew outdoor exhibition uses the following components:

- 1 Flags
- 2 Arch
- 3 Customer promise Sign
- 4 Lighting mast
- 5 Generic banners
- 6 Promotional tarpaulin



The visuals of promotional materials evolve according to the renewal campaigns. Contact Renault Global Marketing to obtain the latest versions.

2.4 General implementation

WHY ?

The general organization of the exhibition area meets the following principles:

- The exhibition is identified by the flags, the signage arch or the area flagpole.
- The central bay connects the entrance to the exhibition area to the sales office.
- This area is marked on the ground. The vehicles offering the most attractive offers are displayed there.
- The other vehicles are presented on either side of the central bay. They are grouped according to the different segments of the renew offer
- The sales office is generally located in line with the central bay. It is identified by the renew signature. A customer promise sign is present at the entrance.

HOW ?

- 1 Flags
- 2 Arch
- 3 Customer promise panel
- 4 Lighting masts
- 5 Generic banners
- 6 Promotional tarpaulin

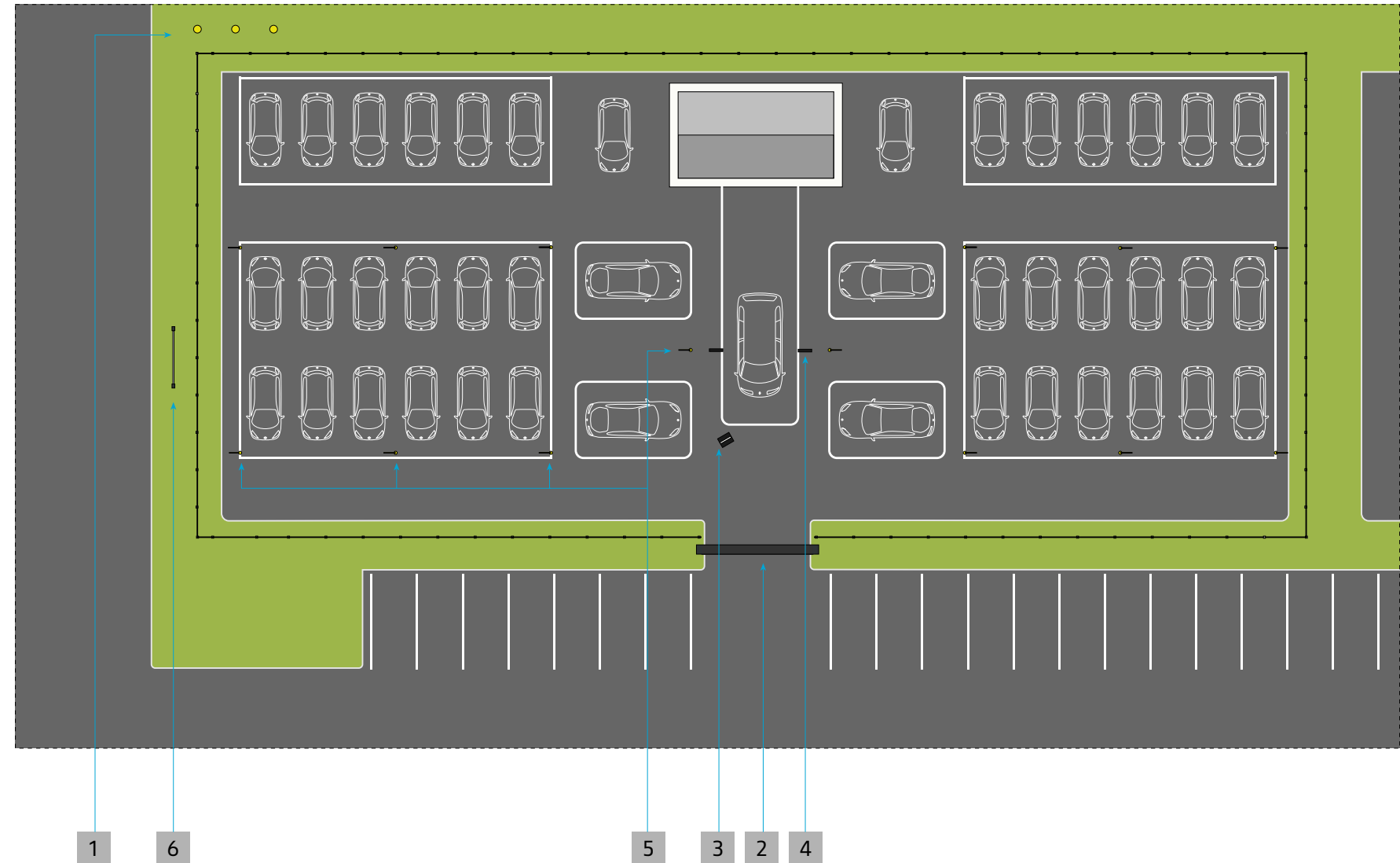

2.5 Central bay

WHY ?

The general organization of the exhibition area meets the following principles:

- The exhibition is identified by the flags, the signage arch or the area flagpole in the case of exhibitions of fewer than 15 vehicles.
- The central bay connects the entrance to the exhibition area

HOW ?

1 renew banners

These elements are positioned on the periphery of the exhibition areas. A banner is also present between the 2 vehicles on display near the central bay.

2 customer promise panel

This element is located near the entrance, in the first exhibition module, at an angle of 30°, preferably on the left side of the central bay, aligned with the edge of the marking at the edge of the module.

3 Lighting masts

These elements are located in the center of the module between the displayed vehicles aligned with the marking of the priority exhibition zone.

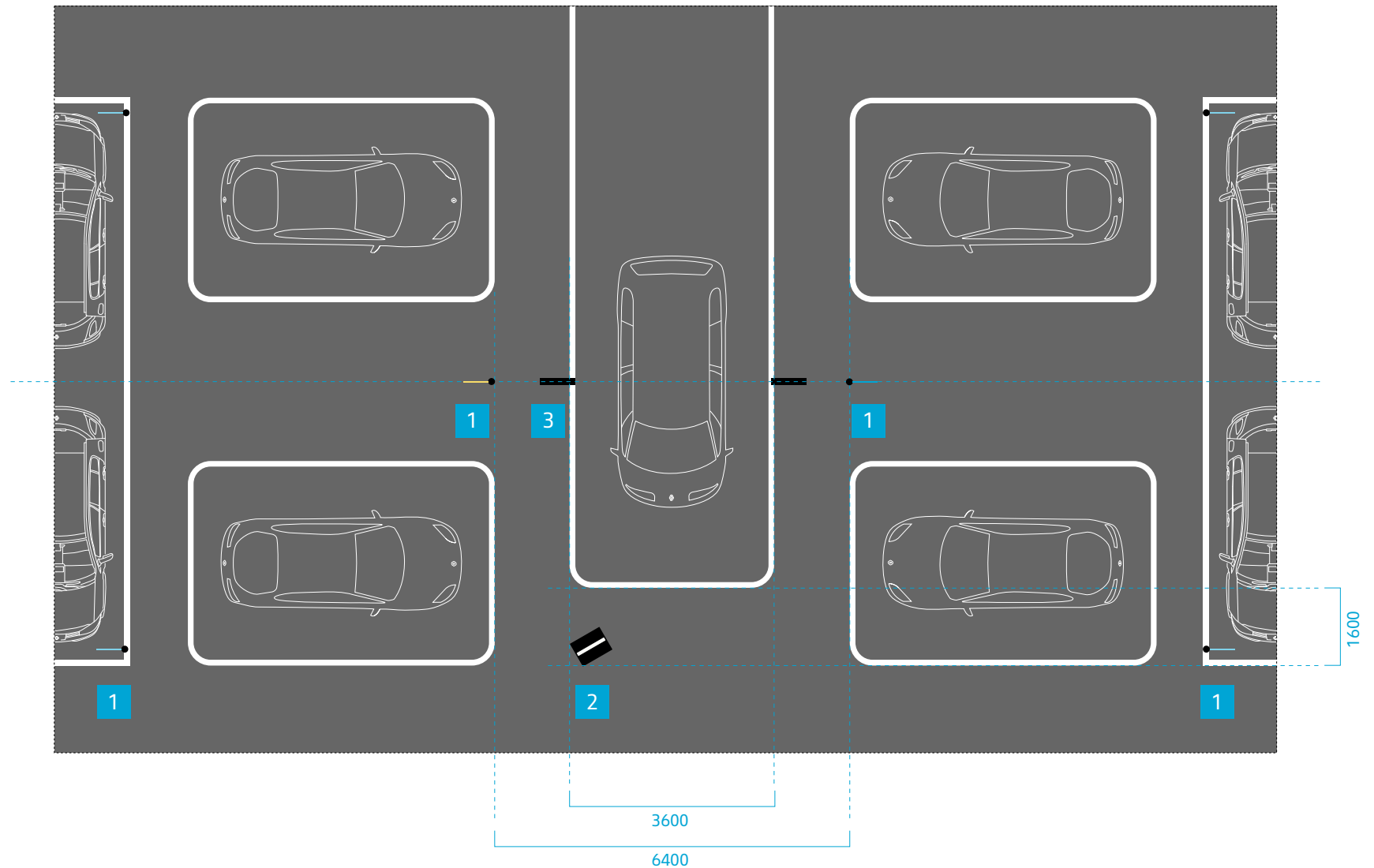

2.6 Exhibition zones

WHY ?

The displayed vehicles are carefully aligned in the exhibition areas arranged on either side of the central bay.

As an option, it is recommended to mark individual parking spaces on the ground in order to facilitate the positioning of vehicles and to present a coherent image.

In front of each exhibition area, priority exhibition areas highlight the vehicles with the most attractive offers.

HOW ?

It is recommended to organize the vehicles in line for reasons of simplicity.

However, depending on the configuration of certain sites, it is possible to arrange the vehicles in a herringbone pattern.

The ground markings demarcating the exhibition areas are made with epoxy paint after marking on the ground.

- 1 Ground markings of the central bay
- 2 Ground markings for priority exposure zones
- 3 Ground markings for exhibition areas

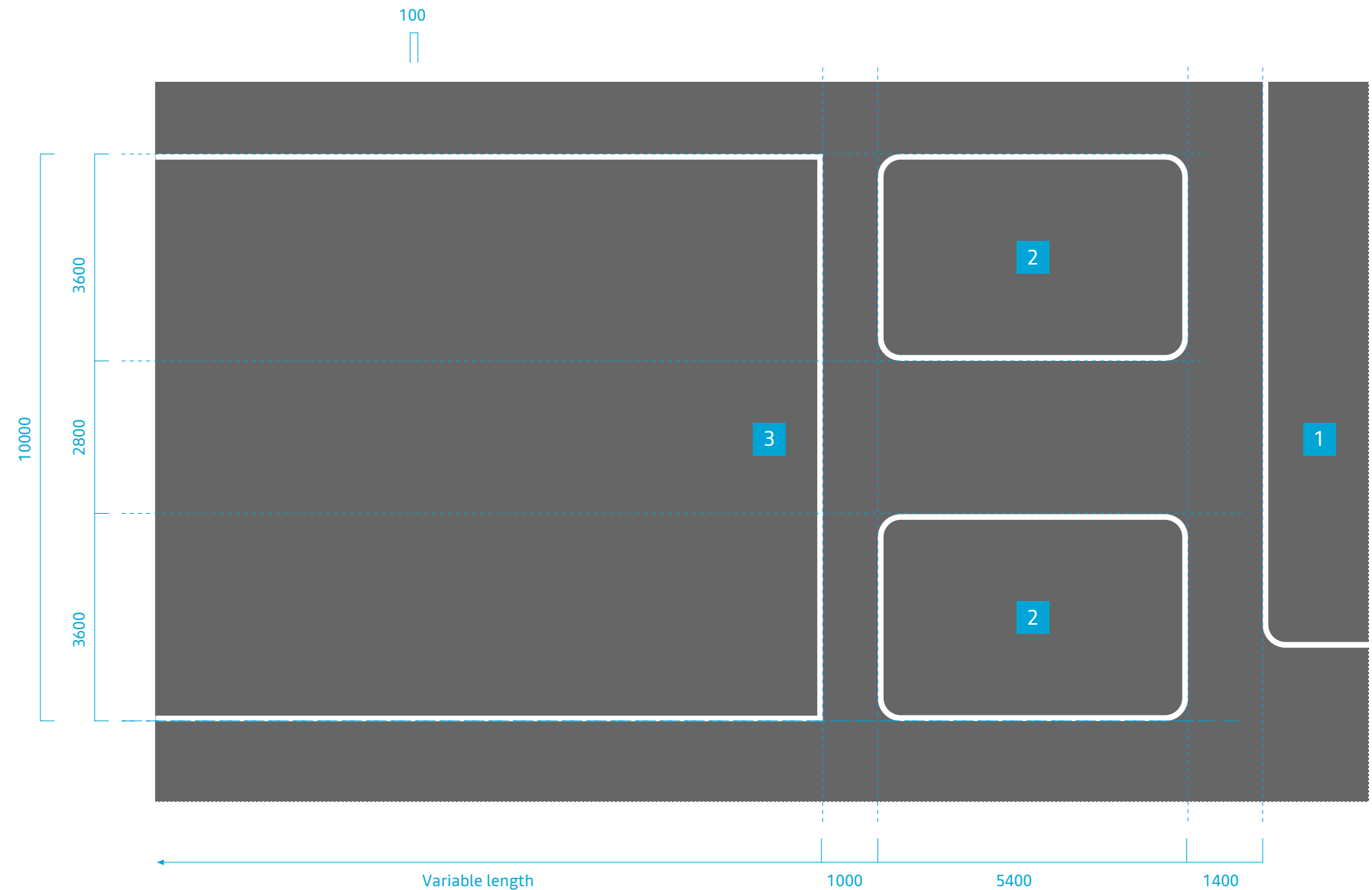

2.7 Modularity

WHY?

The organization of the exhibition areas offers modularity making it possible to adapt to the size of the exhibition areas by varying:

- the number of spans,
- the number of parking slots in each bay.

HOW?

The layout examples opposite illustrate the modularity possible by varying the number of bays.

- 1 1-bay layout
- 2 2-bay layout
- 3 3-bay layout

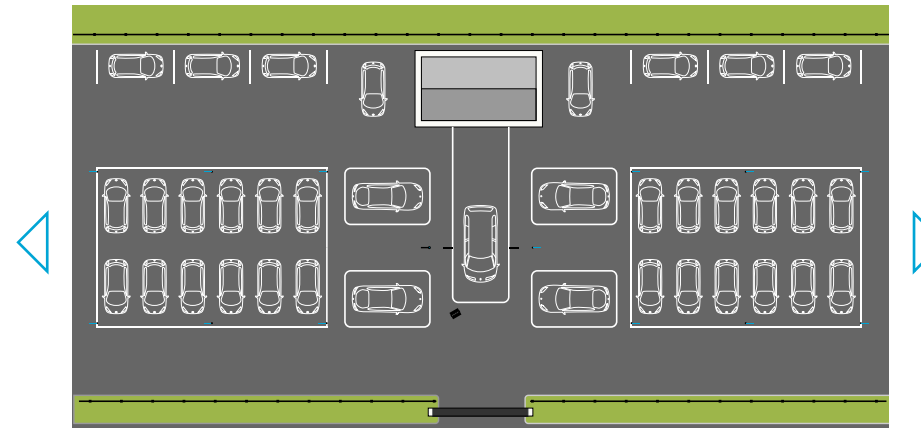

1

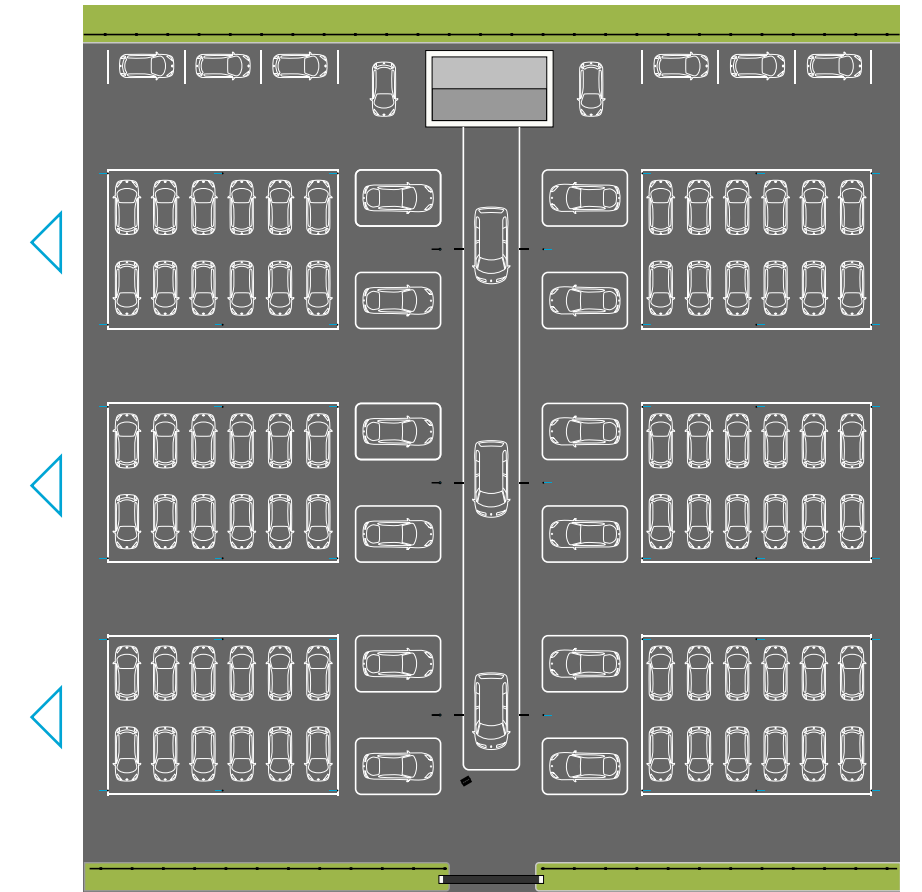

3

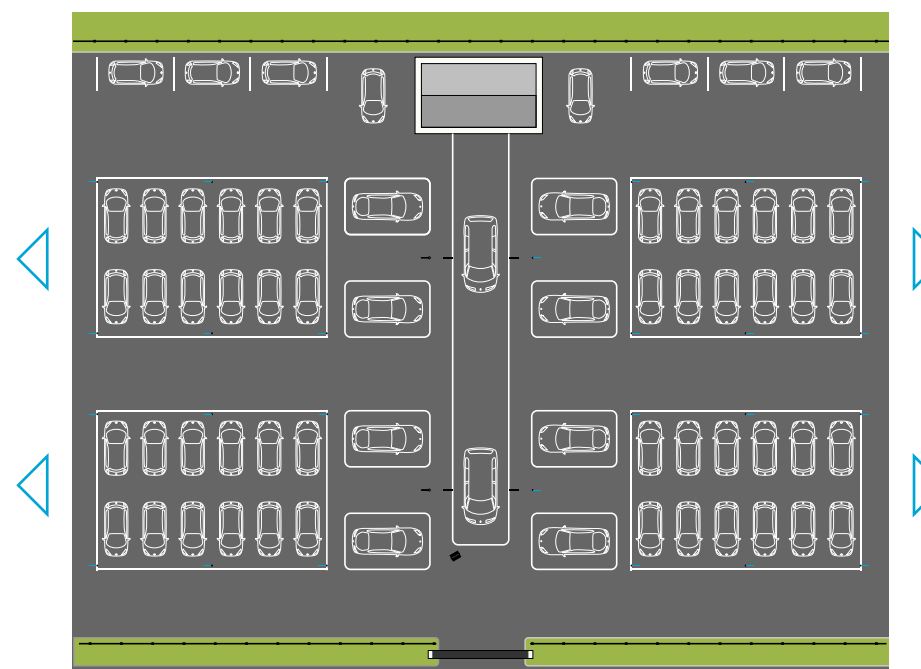

2

2.8 Implementation of a renew corner

WHY?

The renew outdoor exhibition area is located to the side of the showroom.

An access door provides a connection between the offices of the renew advisors and the exterior exhibition.

HOW?

In the showroom, the renew corner presents a used car and allows you to communicate about the renew customer promise and its offers.

It is located close to the access to the renew outdoor exhibition.

- 1 Identification signage.
- 2 renew customer car park.
- 3 renew corner.

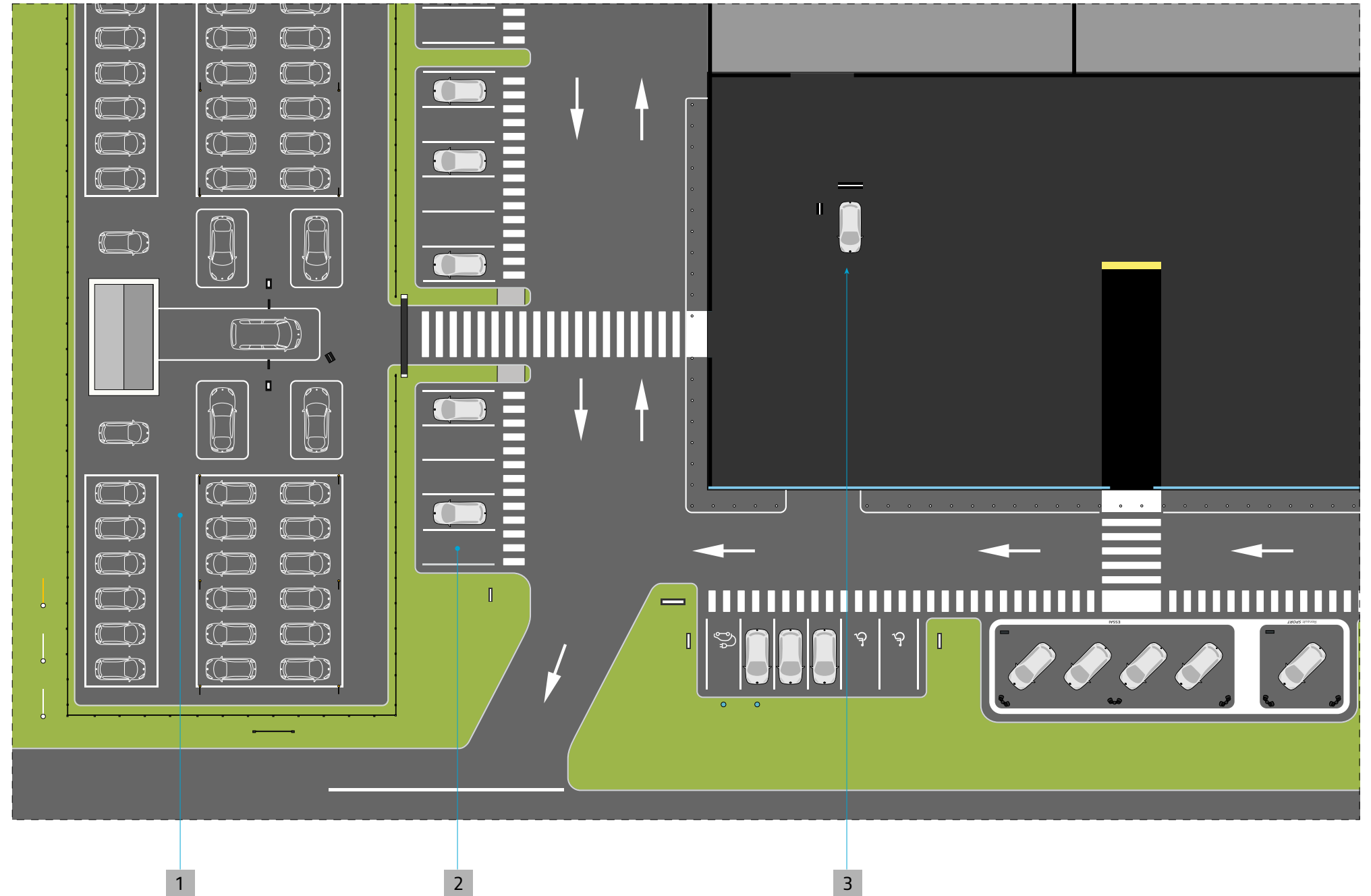

2.9 renew corner

WHY?

The renew corner allows to present a used vehicle in the new vehicles showroom.

It forms the link between the showroom and the renew outdoor exhibition.

It is optional and only concerns a few sites with a showroom surface area large enough for its implementation, requiring around 30 m².

HOW?

- 1 The customer promise is presented on a kakemono totem.
- 2 A 2x2 POS display presents the renew promotional offer.
- 3 A windshield sticker identifies the renew offer offered for each vehicle. It is affixed in the upper left corner of the windshield.
- 4 A renew plate covers the license plate.



The integrated exhibition and corner

2.10 Component table

A FLEXIBLE SYSTEM

In order to provide a consistent customer experience, renew sites include mandatory components.

The optional components make it possible to personalize the offer of each site according to its needs and specificities.

WARNING

This table presents the main lines of use of the different families of components.

Please refer to the detailed description of each of the configurations which are available depending on the number of vehicles present on the site.

Components		from 5 to 15 vehicles ***	> to 15 vehicles ***
Identification signage	renew flags	□	■
	Arch *	■	■
	Area mast *	■	□
Infrastructure	Dedicated customer parking	■	■
	Independent access	■	■
Exterior components	renew flagship zone **	■	■
	Priority exposure areas	■	■
	Markings of exhibition areas	■	■
	Customer promise panel	■	■
	Generic banners	■	■
	Lighting masts	■	■
	Promotional tarpaulin	■	■
	renew sales office	■	■
Showroom	renew sales offices	■	■
	renew corner	■	■

* Arch and area mast should not be used together.

** Except in special cases, the flagshig zone must not be used when an exhibition area exists on the site.

*** Number of vehicles present in each zone.

- mandatory
- optional
- not applicable

3

THE INTEGRATED SHOWROOM AND EXHIBITION

3.1 What are we talking about ?

WHY?

Part of the showroom is dedicated to the exhibition of used vehicles presenting the most attractive offers.

Renew advisors have offices allowing them to welcome renew clients.

The exterior exhibition is present in the majority of cases, completing the renew offer.

As an option, a sales area can be integrated into the outdoor exhibition.

HOW?

- 1 Dedicated customer parking is available near the showroom offering customers independent access.
- 2 The access dedicated to the renew activity has specific signage.
- 3 Inside the showroom, renew sales advisors welcome customers in dedicated offices.
- 4 In addition, the renew outdoor exhibition is located on one side of the site, accessible via protected passages.
- 5 The renew exhibition area is identified by flags and a signage arch.
- 6 The renew exhibition can be located either to the right or to the left of the building housing the new vehicles showroom.

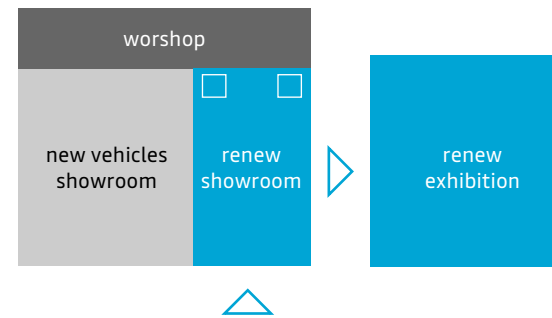

Location of the exhibition to the right of the renew showroom.
Sales offices are in the showroom.

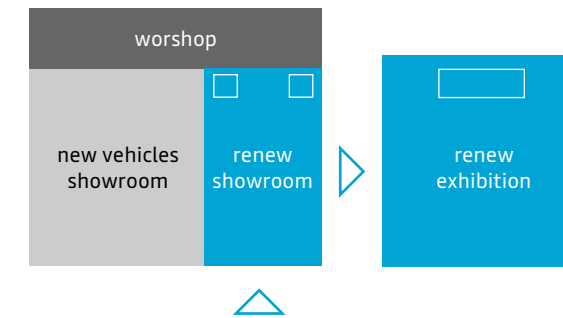

Location of the exhibition to the right of the renew showroom.
Variant with sales area in the exhibition.

3.2 Typical facades

WHY?

The renew showrooms are generally integrated into a new vehicles showroom with which they share the main facade.

The identification of the presence of renew must be consistent with the overall identification of the site with the Renault brand.

HOW?

- 1 The front of the renew showroom is painted RAL 9010 white.
- 2 The renew signature on a dark grey background is located above the dedicated entrance door.
- 3 A customer promise panel is present to the right of the access door dedicated to the renew showroom.
- 4 The facade of the Renault showroom is clad in metallic mesh with the Renault signature and the dealername.
- 5 The facades of the renew showrooms of the 100% Renault brand networks (LATAM, India, etc.) are characterized by the metal mesh which covers the entire facade pediment. The Renault signature is positioned opposite the renew showroom.

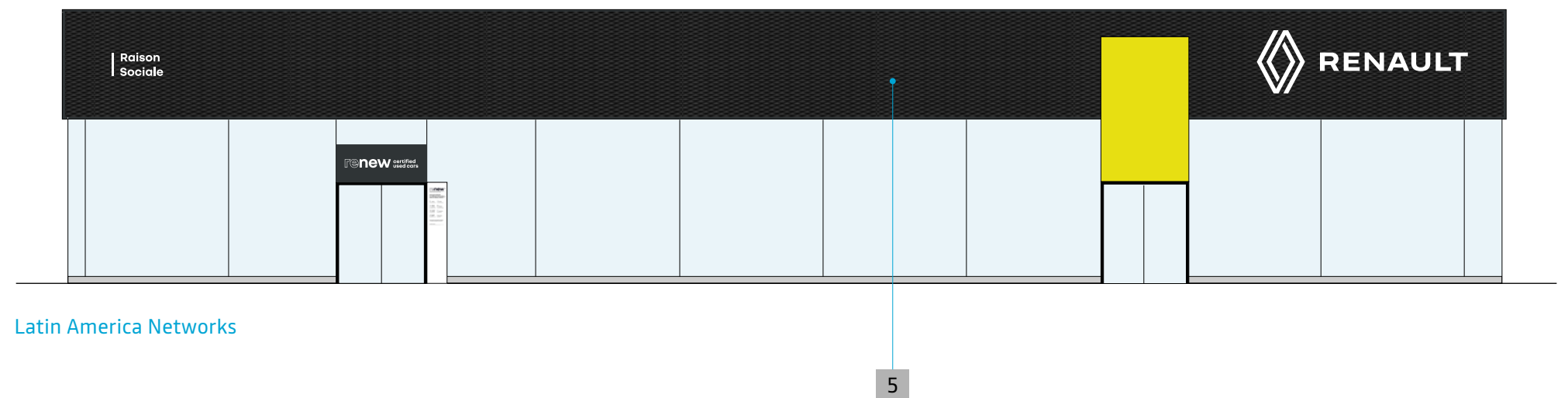
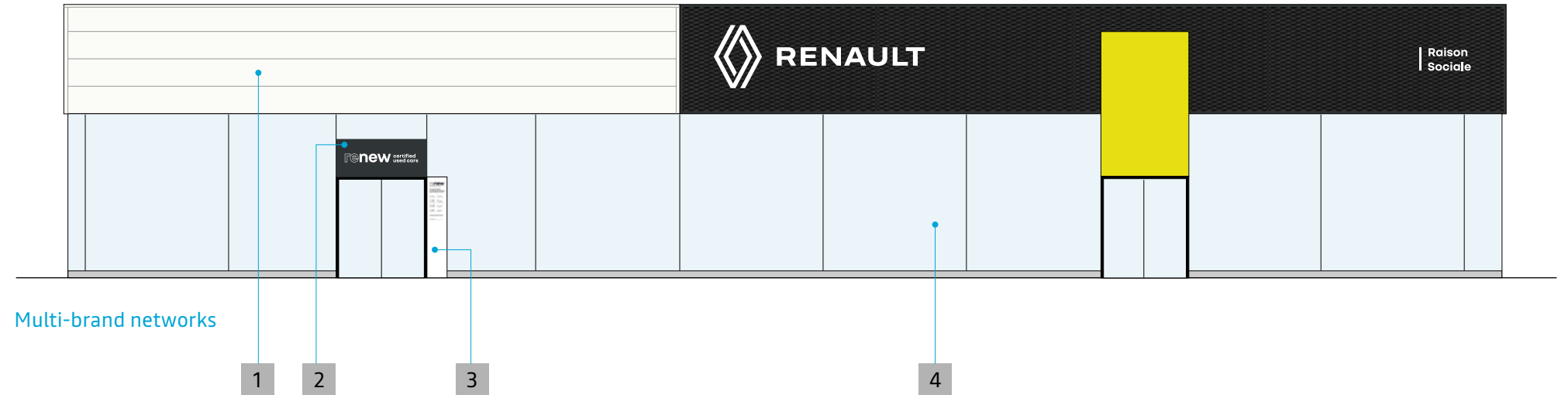

3.3 General view

WHY?

Generally, the renew showroom is integrated into a Renault building.

The common components are as follows:

- dark grey tiles,
- RAL 9010 white walls,
- RAL 7021 dark grey lacquered aluminum window frames and white glass window.

The interior design uses elements specific to the renew universe.

HOW?

- 1 Upon entering the exhibition, the promise panel presents the elements of the customer promise.
- 2 Due to its orientation and continuity, the central bay guides customers as they move around the showroom and encourages the organization of vehicles around this axis.
- 3 The brand wall features the full renew signature. It is located on the back wall of the exhibition in line with the central bay.
- 4 The vehicles are arranged perpendicular to the central bay. They are grouped according to the different segments of the renew offer.
- 5 The sales offices are located at the back of the exhibition, decorated with a large-format wall display.

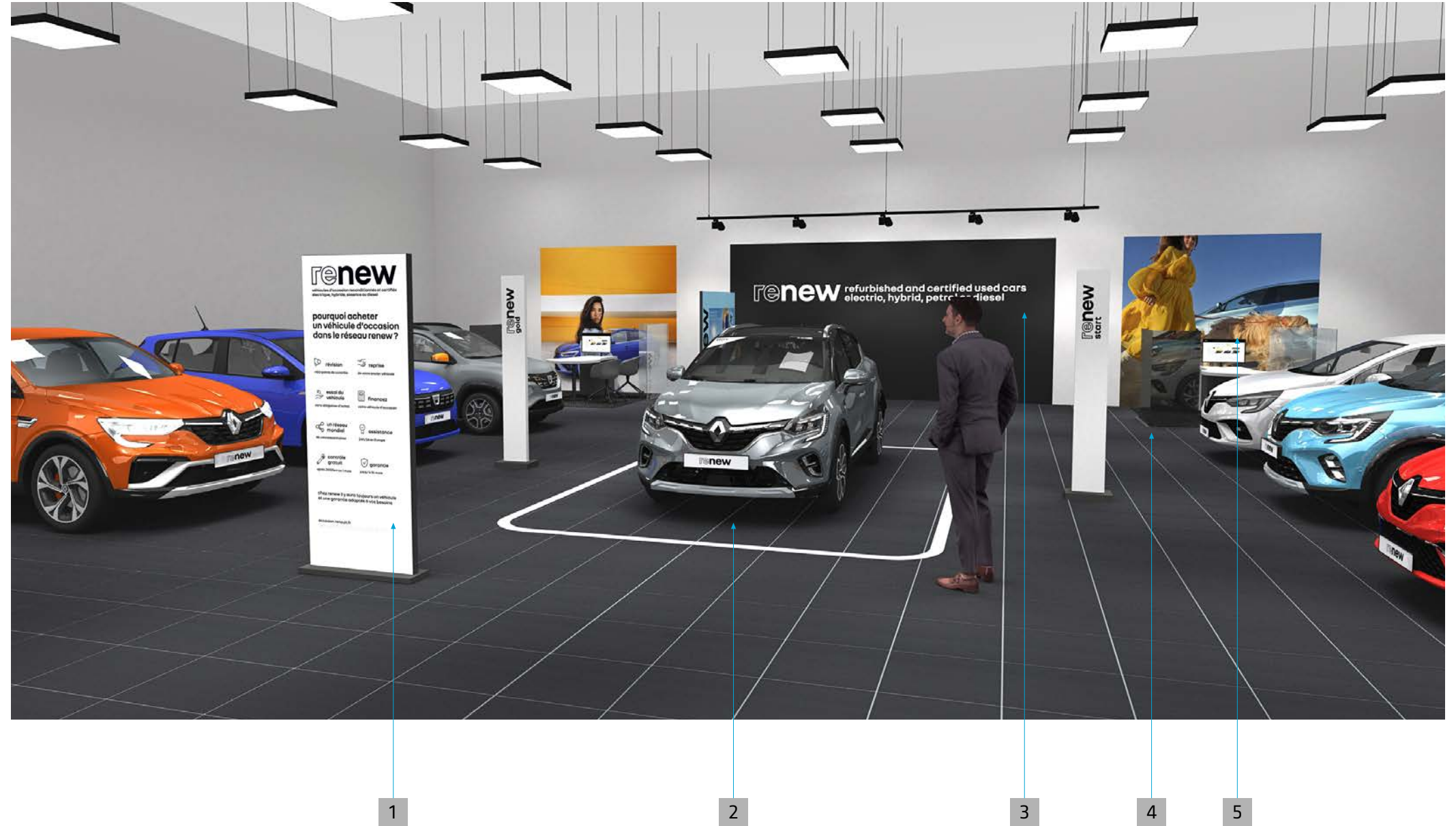

3.4 Components

KEY

The communication and information supports of the renew showrooms are as follows:

- 1 The customer promise panel.
- 2 Area panels.
- 3 renew brand wall.
- 4 Identification box.
- 5 renew 2x2 promotional POS.
- 6 Vehicle identification.



3.5 Lay out of a renew showroom

WHY?

The general organization of the renew showroom is based on a central axis to structure the presentation of the vehicles.

Components specific to the renew universe punctuate customer journeys in the showroom.

HOW?

- 1 The customer promise panel is installed upon entering the showroom.
- 2 The central bay highlights vehicles benefiting from an attractive offer.
- 3 The area panels structure the exhibition according to the renew segments.
- 4 The exhibition areas present the vehicles ordered according to a multiple of 3, with the fronts always oriented towards the central bay.
- 5 The sales offices are located at the back of the exhibition, on either side of the central bay.
- 6 The renew brand wall is installed on the back wall of the showroom, on the axis of the central bay.
- 7 The 2x2 POS is perpendicular to the renew brand wall.
- 8 The identification box is located at the edge of the new vehicles showroom, in line with the passage or the entrance door.

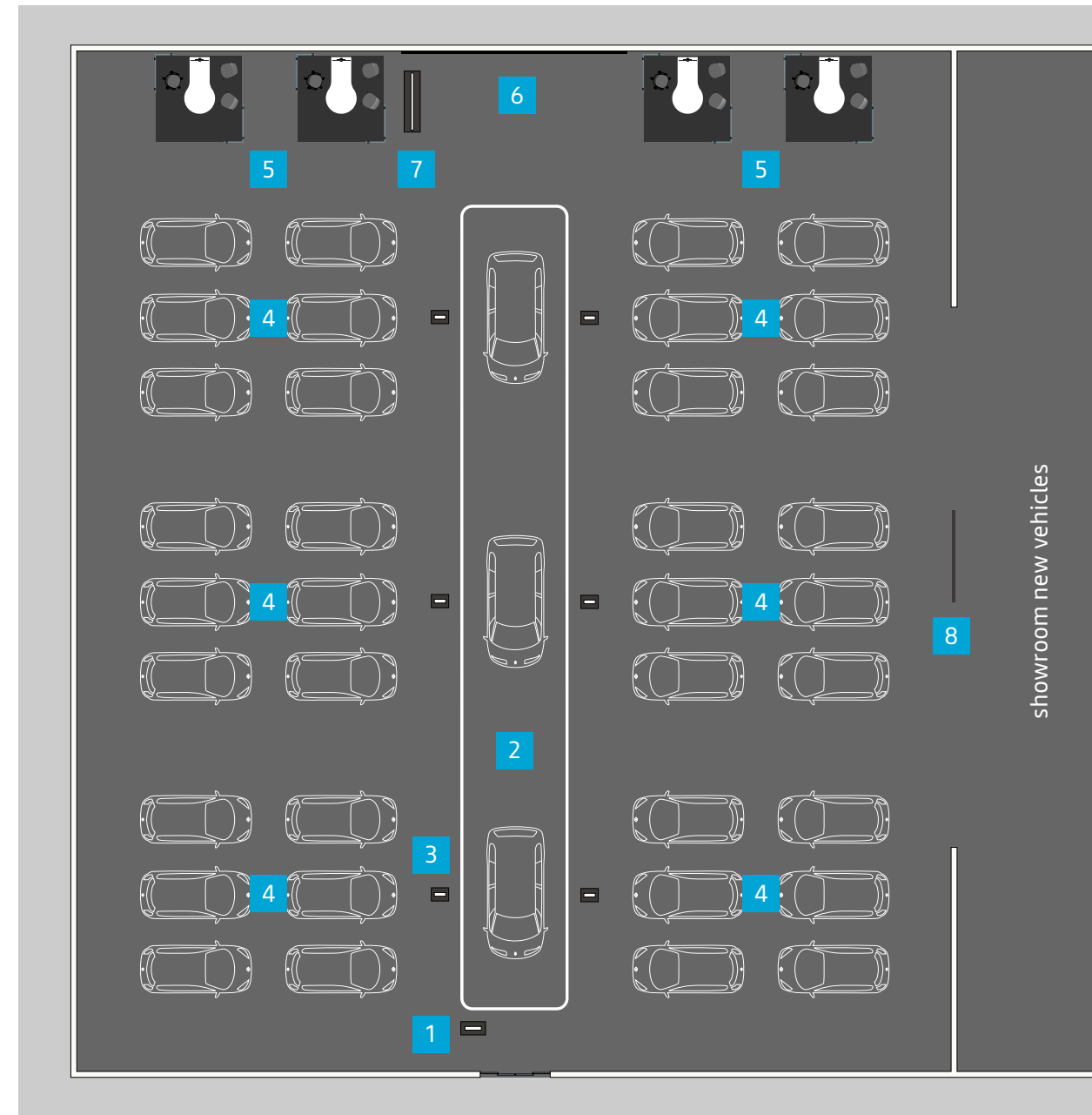

3.6 Lay out of the front bay

WHY?

The front part benefits from a special treatment inviting the customer to enter the showroom.

As soon as they enter the front door, the customer can read the renew customer promise before discovering the models on display.

HOW?

1 The customer promise panel

This panel is installed parallel to the front door. Preferably, it is aligned on the left edge of the central marking, at the edge of the first module.

2 Area panels

These panels are located in the center of the module between the vehicles on display, aligned on the edge of the exhibition area.

3 Marking of the central bay

This floor marking is made of matte white adhesive. It creates a central axis for the exhibition of vehicles, making it possible to define a presentation area for the most attractive vehicles.

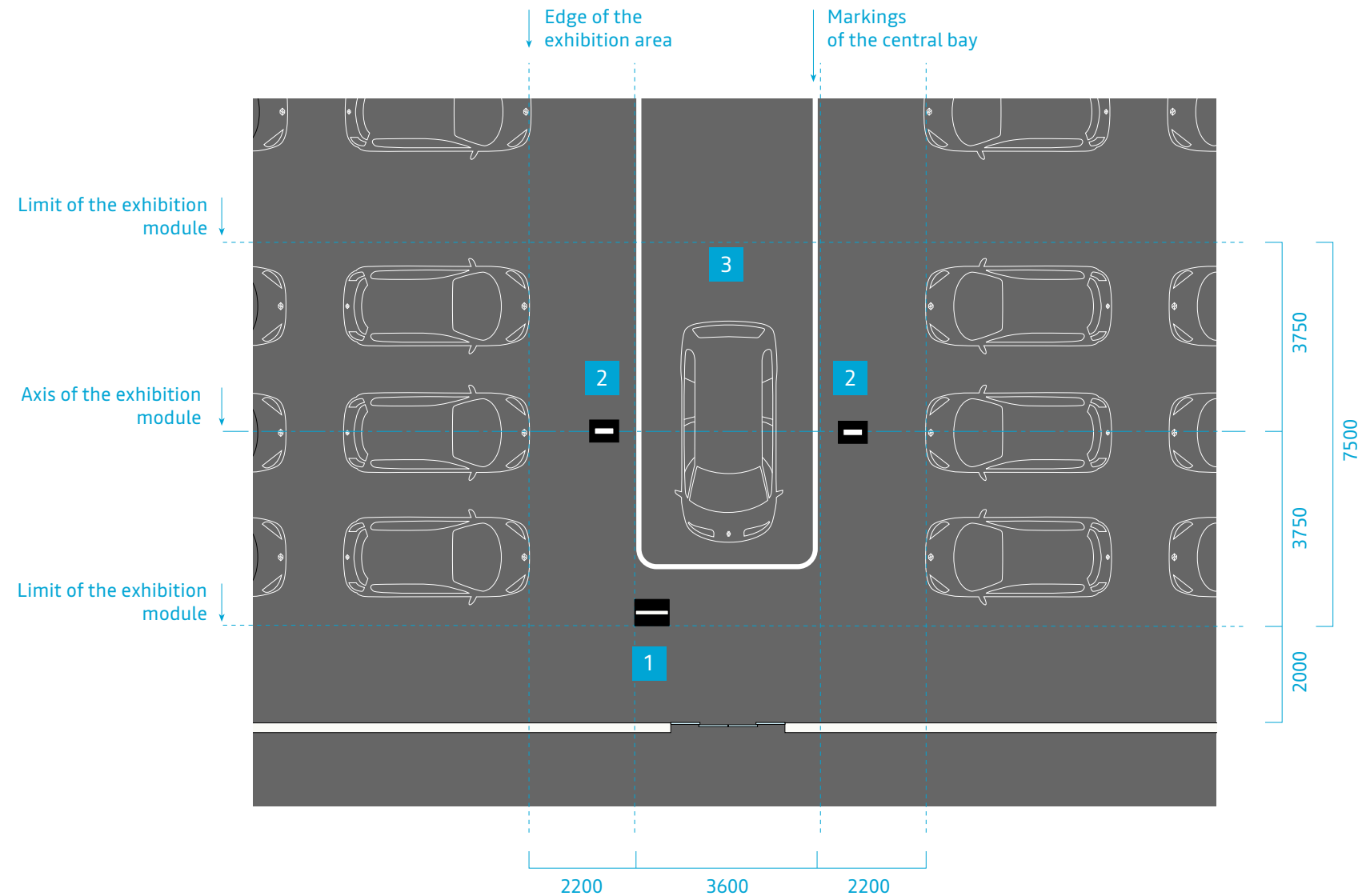

3.7 The vehicle exhibition module

WHY?

The exhibition module is the 7500 mm component used to organize the Renault Selection showroom.

HOW?

- 1 In the central bay, the cars offering the most attractive offer are arranged.
- 2 The central bay is framed by 2 circulation aisles guiding customers in their exploration of the showroom.
- 3 In the exhibition areas, the cars are arranged in a row at 90°, the front always facing the central bay.
- 4 The vehicles are aligned together forming several orderly rows offering good visibility while preserving their accessibility.

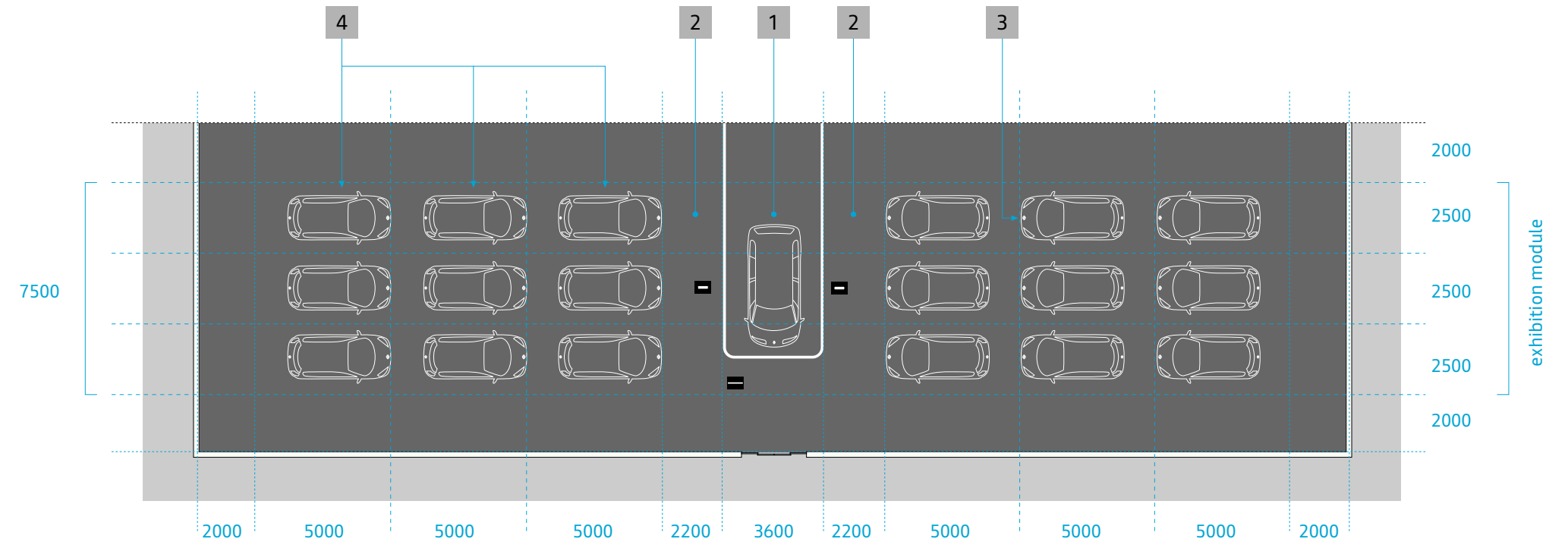

3.8 Lay out of the vehicle exhibition module

WHY?

The vehicles are grouped into segments according to an exhibition module comprising a multiple of 3 vehicles.

This arrangement offers the advantage of structuring the exhibition but also of facilitating access to vehicles.

HOW?

- 1 The exhibition modules are separated from a circulation aisle.
- 2 This traffic aisle has a minimum width of 2000 mm allowing vehicles to be placed in the showroom.
- 3 The marking of the central bay is continuous, connecting the exhibition modules.
- 4 As far as possible, a circulation aisle with a minimum width of 2000 mm is installed around the periphery of the showroom.

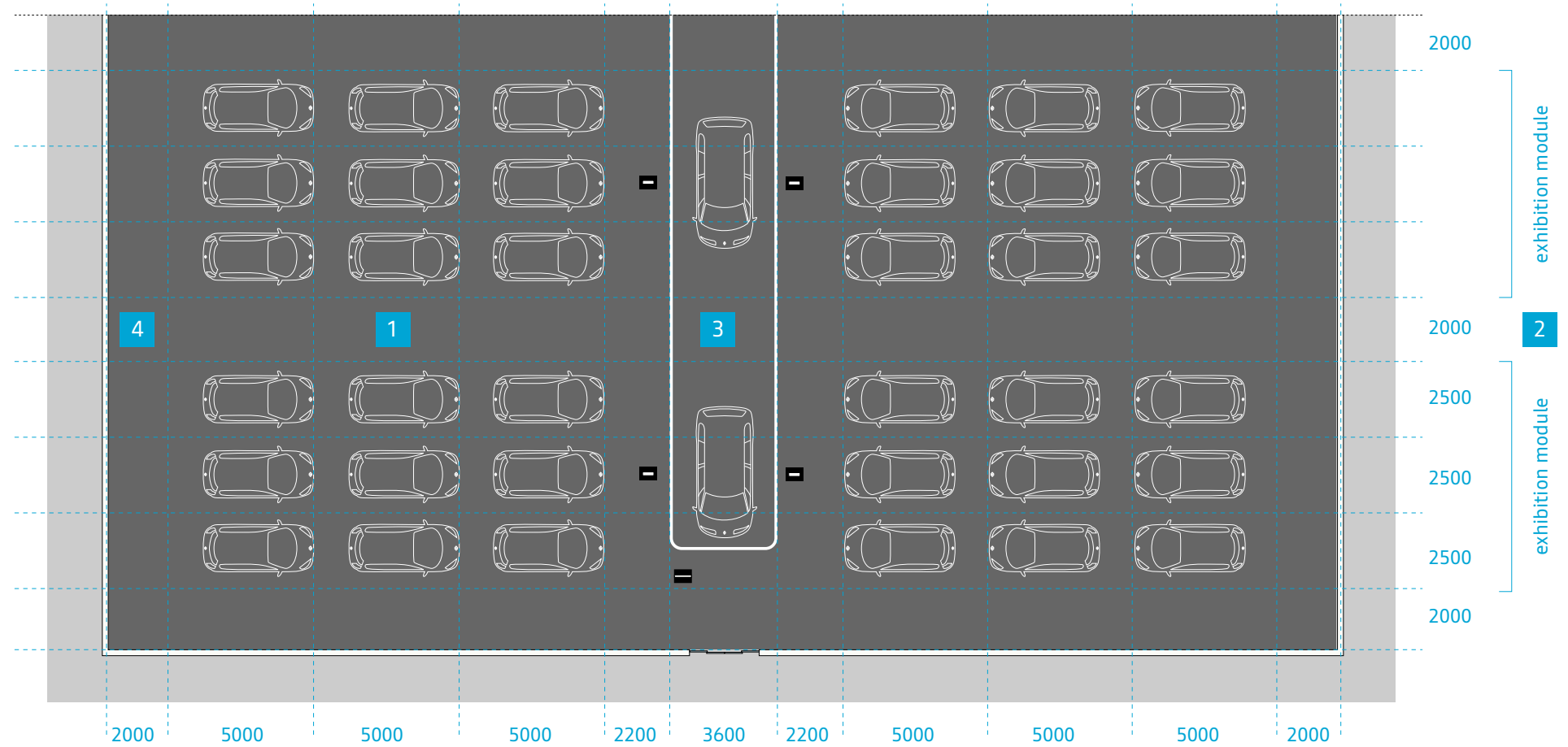

3.9 The showroom back module

WHY?

The back module is based on the attractiveness exerted by the renew brand wall, possibly supplemented by large format visuals placed behind the open sales offices.

HOW

- 1 The back module of the showroom has a minimum width of 3000 mm.
- 2 It is separated from the last exhibition module of the vehicles by a circulation with a minimum width of 2000 mm.
- 3 The sales offices are located there, on either side of the central axis or if necessary, in front of the renew brand wall.
- 4 A black wall fresco with the renew full signature is installed in the axis of the exhibition against the back wall.
- 5 The marking of the central bay stops at the limit of the last exhibition module of the vehicles.

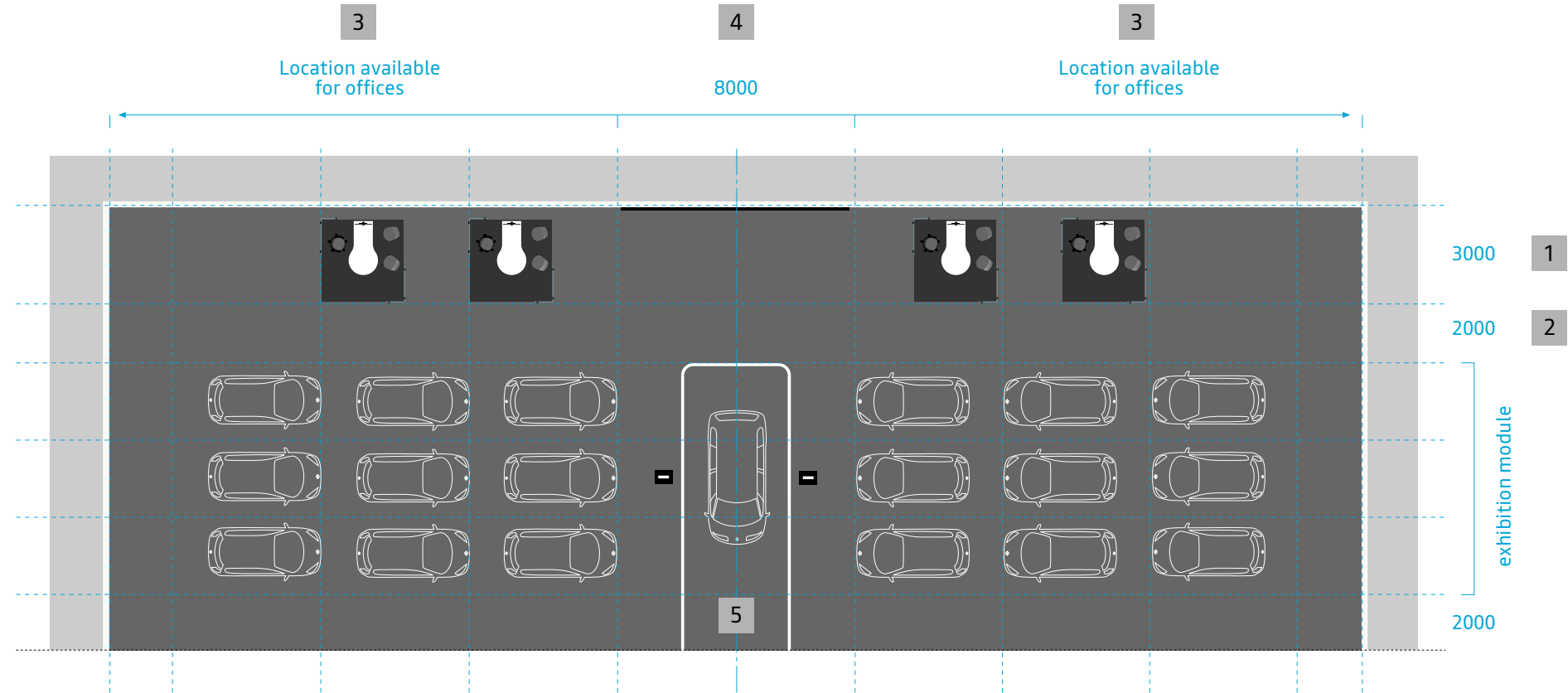

3.10 Lay out of vehicles

WHY?

The layout of the vehicles must offer an organized appearance and stand out at first glance from that adopted in the new vehicles showroom.

HOW?

- 1 The vehicles are parked in a row at 90° to the central bay.
- 2 In the central bay, the front of the vehicles always faces the entrance to the showroom.
- 3 The vehicles are grouped into 7.5 m wide exhibition modules, comprising 3 lines of vehicles.
- 4 These modules have several rows depending on the width of the showroom. The front of the vehicles is aligned with the fictitious route.
- 5 The exhibition modules do not have floor markings. The vehicles are aligned on the fictitious limits of the exhibition zones.

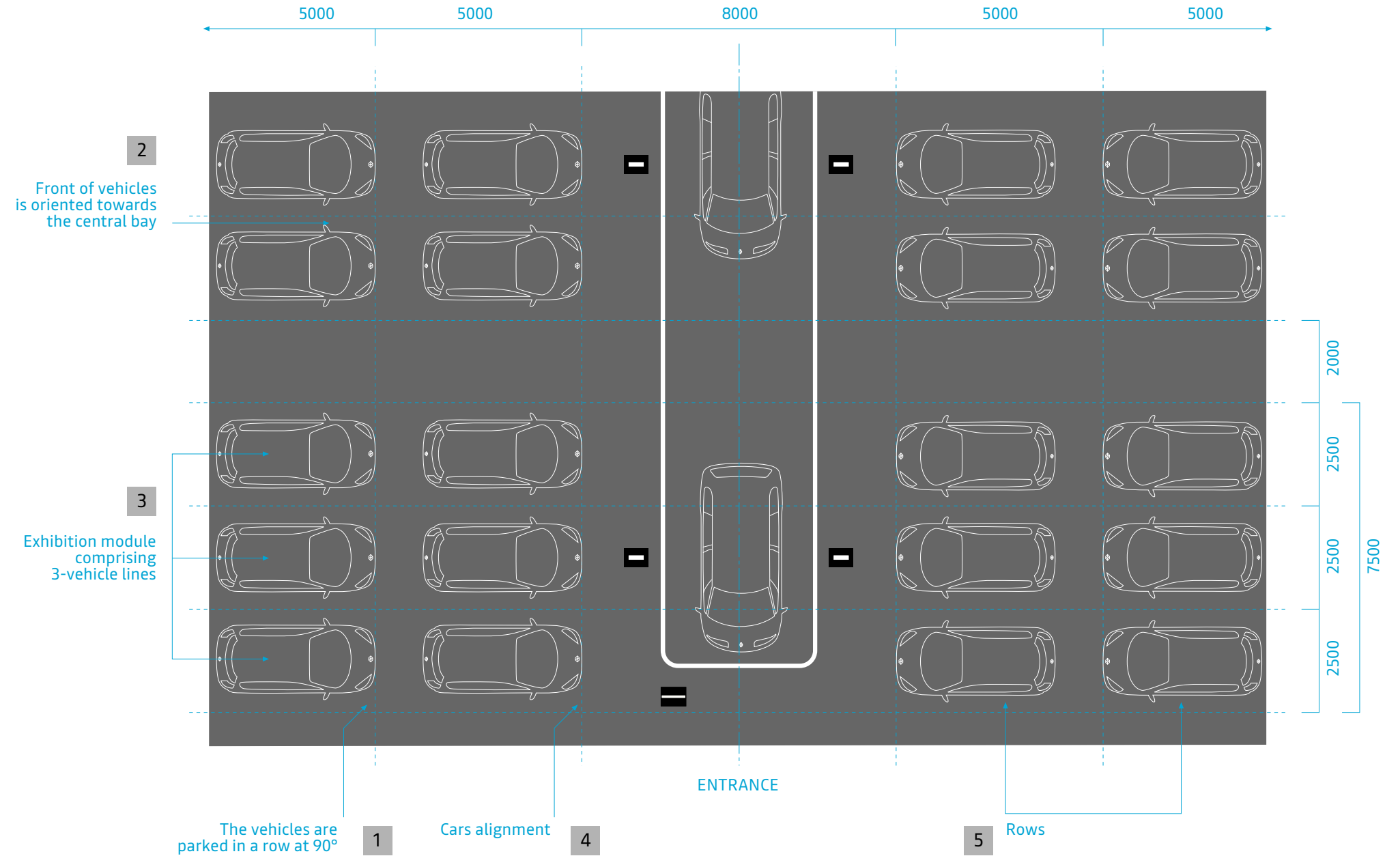

3.11 Central bay

WHY?

The central bay highlights the vehicles with the most attractive offers.

To this end, the vehicles on display have an upper exhibition surface allowing customers to walk around them easily while facilitating access.

HOW?

- 1 The floor marking is centered in relation to the axis of the main bay.
- 2 As far as possible, the floor markings are aligned with the joints of the exhibition tiles.
- 3 The vehicle is centered in the area. The doors must be able to open while preserving a passage between the exposed vehicles.

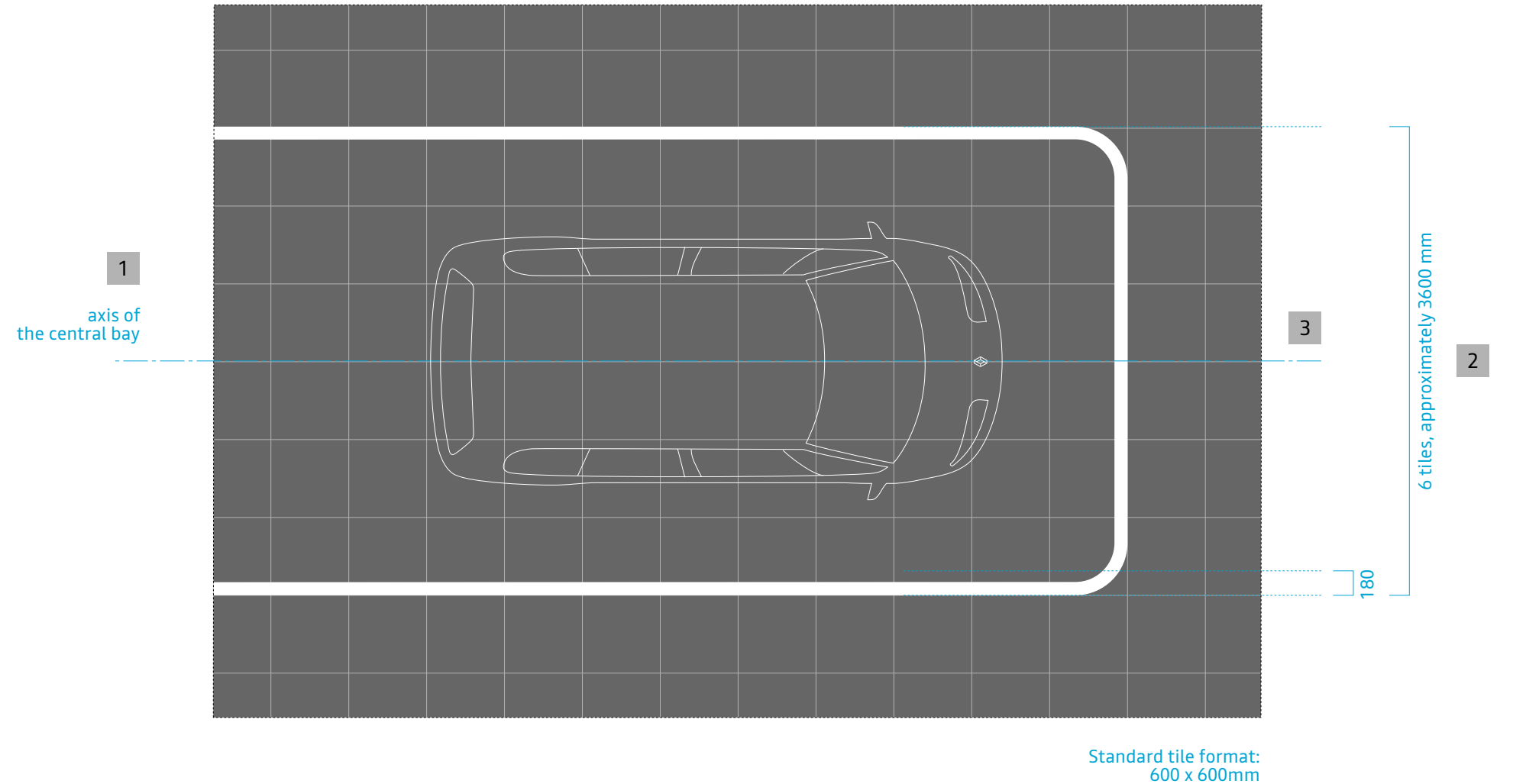

3.12 Components of the central bay

WHY?

The central bay naturally invites the customer to discover the entire exhibition.

Circulation is provided on both sides of this central axis.

HOW?

- 1 The floor marking of the central bay is centered in relation to the axis of the showroom.
- 2 Marking begins 1m from the edge of the first module.
- 3 A circulation path, with a minimum width of 2m, is present between the entrance to the showroom and the first exhibition module.
- 4 The customer promise sign is preferably installed on the left edge of the central bay, 1m offset from the front of the marking.
- 5 The area panels are positioned in the side circulations, near the marking of the central bay.

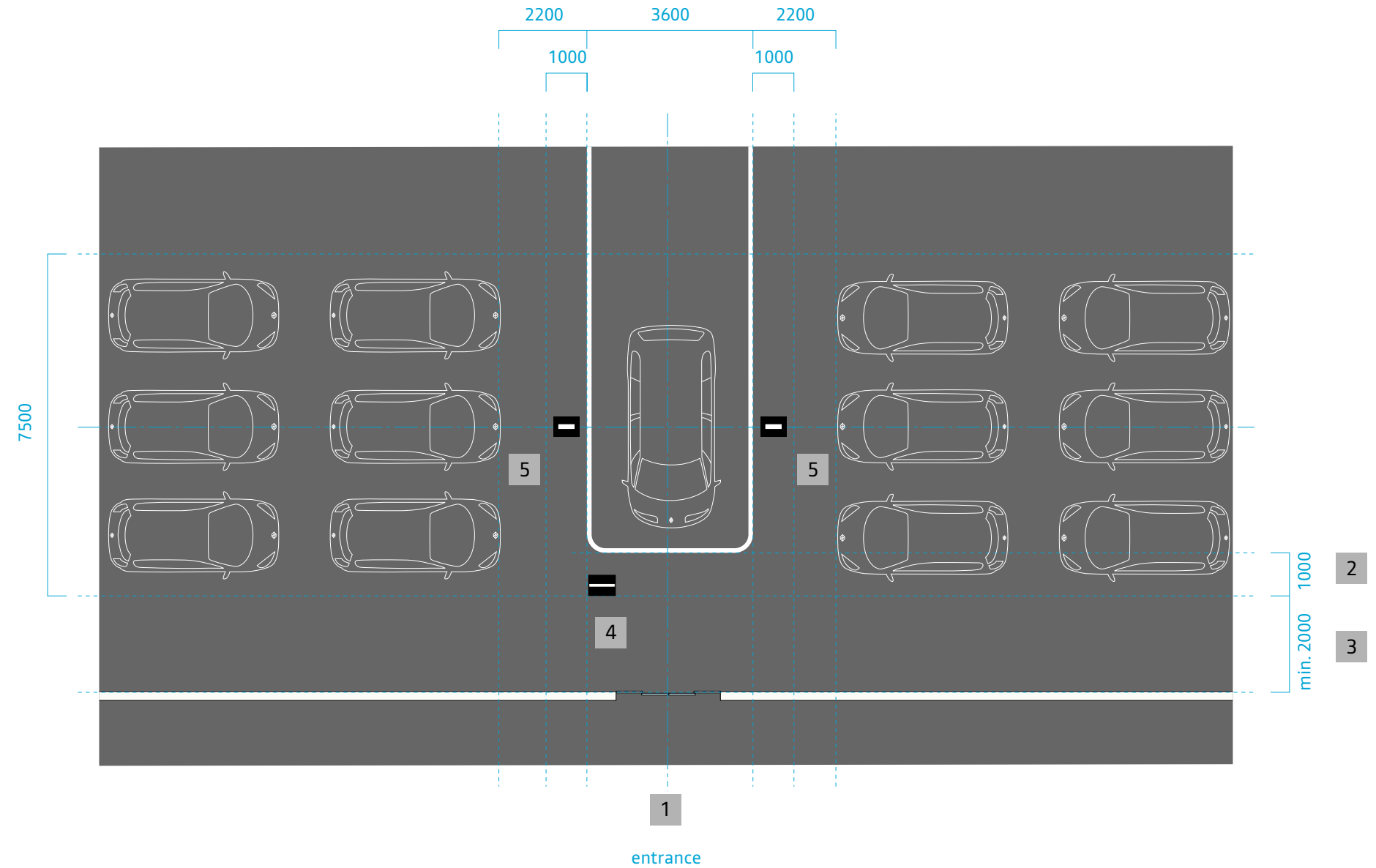

3.13 Open offices of renew advisors

WHY?

One or more renew advisors may be present in the new vehicles showrooms.

To welcome customers, they have open offices located near the back wall of the renew exhibition.

HOW?

- 1 The back wall of the renew showroom has the renew brand wall and its full signature in its center.
- 2 The 2x2 POS is installed perpendicular to the back wall. It is preferably aligned on the left side of the branding wall.
- 3 On either side of the brand wall, the sales offices can be located symmetrically, their number depending on the number of dedicated sales people and the surface area of the renew showroom.



3.14 Component table

A FLEXIBLE SYSTEM

In order to provide a consistent customer experience, renew sites include mandatory components.

The optional components make it possible to personalize the offer of each site according to its needs and specificities.

WARNING

This table presents the main lines of use of the different families of components.

Please refer to the detailed description of each of the configurations which are available depending on the number of vehicles present on the site.

* Arch and area mast should not be used together.
 ** Except in special cases, the flagshig zone must not be used when an exhibition area exists on the site.
 *** Number of vehicles present in each zone.

- mandatory
- optional
- not applicable

Components		from 5 to 15 vehicles ***	> to 15 vehicles ***
Identification signage	renew flags	□	■
	Arch *	■	■
	Area mast *	■	□
Infrastructure	Dedicated customer parking	■	■
	Independent access	■	■
Components of the outdoor exhibition	renew flagship zone	■	■
	Priority exposure areas	■	■
	Markings of exhibition areas	■	■
	Customer promise panel	■	■
	Generic banners	■	■
	Lighting masts	■	■
	Promotional tarpaulin	■	■
	renew sales office	□	□
Showroom facade	renew entrance marking	■	■
	Customer promise panel	■	■
Showroom components	renew brand wall	■	■
	Customer promise panel	■	■
	Identification box	■	■
	Area panels	■	■
	renew sales offices	■	■
	2x2 POS	■	■

4

THE INDEPENDENT SITE

4.1 What are we talking about ?

WHY?

Part of the showroom is dedicated to the exhibition of used vehicles presenting the most attractive offers.

Renew advisors have offices allowing them to welcome renew customers.

The exterior exhibition is present in the majority of cases, completing the renew offer.

HOW?

- 1 Customer car park is located on one side of the showroom.
- 2 Entrance is always through the central door. Pedestrian paths connect the different areas ensuring customer safety.
- 3 In front of the showroom, the priority exhibition areas present the vehicles with the most attractive offers.
- 4 Inside the showroom, renew sales advisors welcome customers in dedicated offices.
- 5 In addition, the renew outdoor exhibition is located on one side of the site, accessible via pedestrian paths.
- 6 The renew exhibition can be located either to the right or to the left of the building housing the new vehicles showroom.
- 7 As an option, the back office can include a finishing and preparation area for used vehicles.

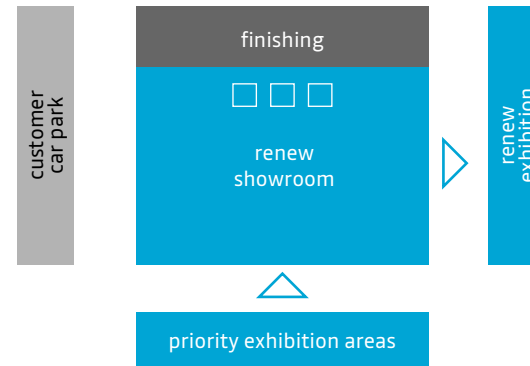

General layout with a small outdoor exhibition

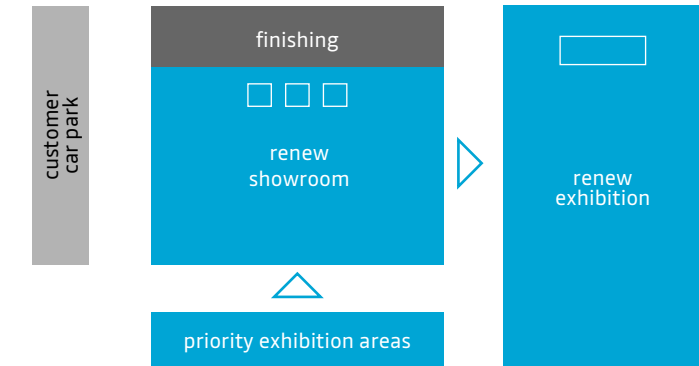

General layout with a large format outdoor exhibition

4.2 Typical facade of 100% Renault networks

WHY?

The facades of the showrooms of the independent renew sites of the 100% Renault networks have specific identification.

HOW?

- 1 A series of Renault flags is implanted, as a priority, on one side of the site.
- 2 The renew signature is located on the dark grey facade pediment.
- 3 A customer promise panel is located to the right of the main entrance door to the showroom.
- 4 The dark grey background (RAL 7021 satin at 40% gloss) of the facade can be produced using different processes adapted to each situation (new construction or existing building): dark grey cladding or facade painting.
- 5 The dealername is located on the facade, opposite the renew signature.
- 6 A series of renew flags are located on one side of the site.



NOTE

Metal mesh should not be used on the facades of independent renew sites.

4.3 Typical facade of Renault Group multi-brand networks

WHY?

The facades of the showrooms of the independent renew sites of the Renault Group multi-brand networks have specific identification.

HOW?

- 1 A series of Renault Dacia flags is placed, as a priority, on one side of the site.
- 2 The renew signature is located on the dark grey facade pediment.
- 3 A customer promise panel is located to the right of the main entrance door to the showroom.
- 4 The dark grey background (RAL 7021 satin at 40% gloss) of the facade can be produced using different processes adapted to each situation (new construction or existing building): dark grey cladding or facade painting.
- 5 The dealername is located on the facade, opposite the renew signature.
- 6 A series of renew flags are located on one side of the site.

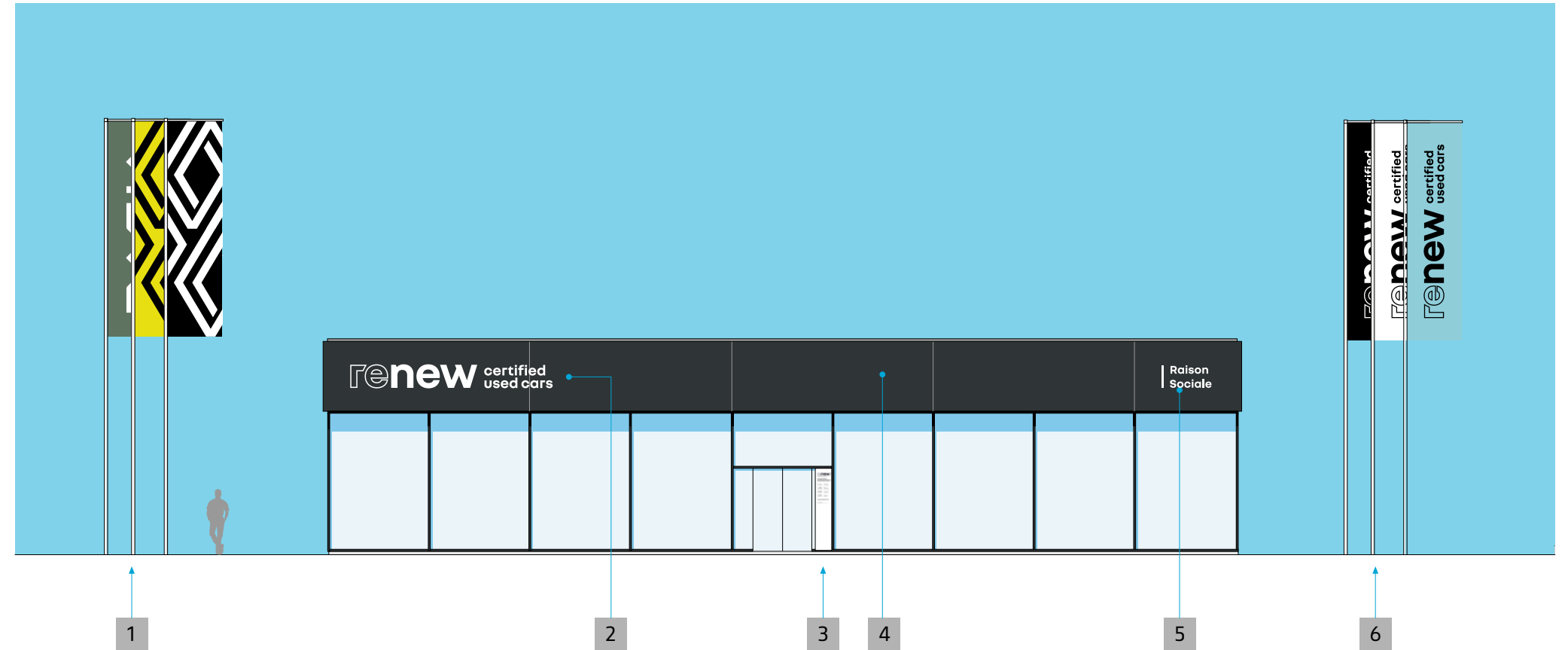

NOTE

Metal mesh should not be used on the facades of independent renew sites.

4.4 General layout of the site

WHY?

The organization of the independent renew sites concentrates all the functionalities implemented within the framework of the integrated sites in order to offer a homogeneous customer journey.

HOW?

- 1 The customer car park is located on one side of the site.
- 2 The most attractive vehicles in the renew offer are displayed in front of the showroom.
- 3 The organizational principles of the renew showroom are identical to those used within the integrated sites.
- 4 The renew flagship zone draws attention to a vehicle with a particularly attractive offer.
- 5 As an option, a used vehicle finishing and preparation area can be integrated into the back office, when vehicle preparation is integrated on the stand-alone site.
- 6 In addition to the vehicles displayed in the showroom, other vehicles for sale can be presented in parking lots located on the sides of the building.
- 7 A series of renew flags are located on one side of the site.

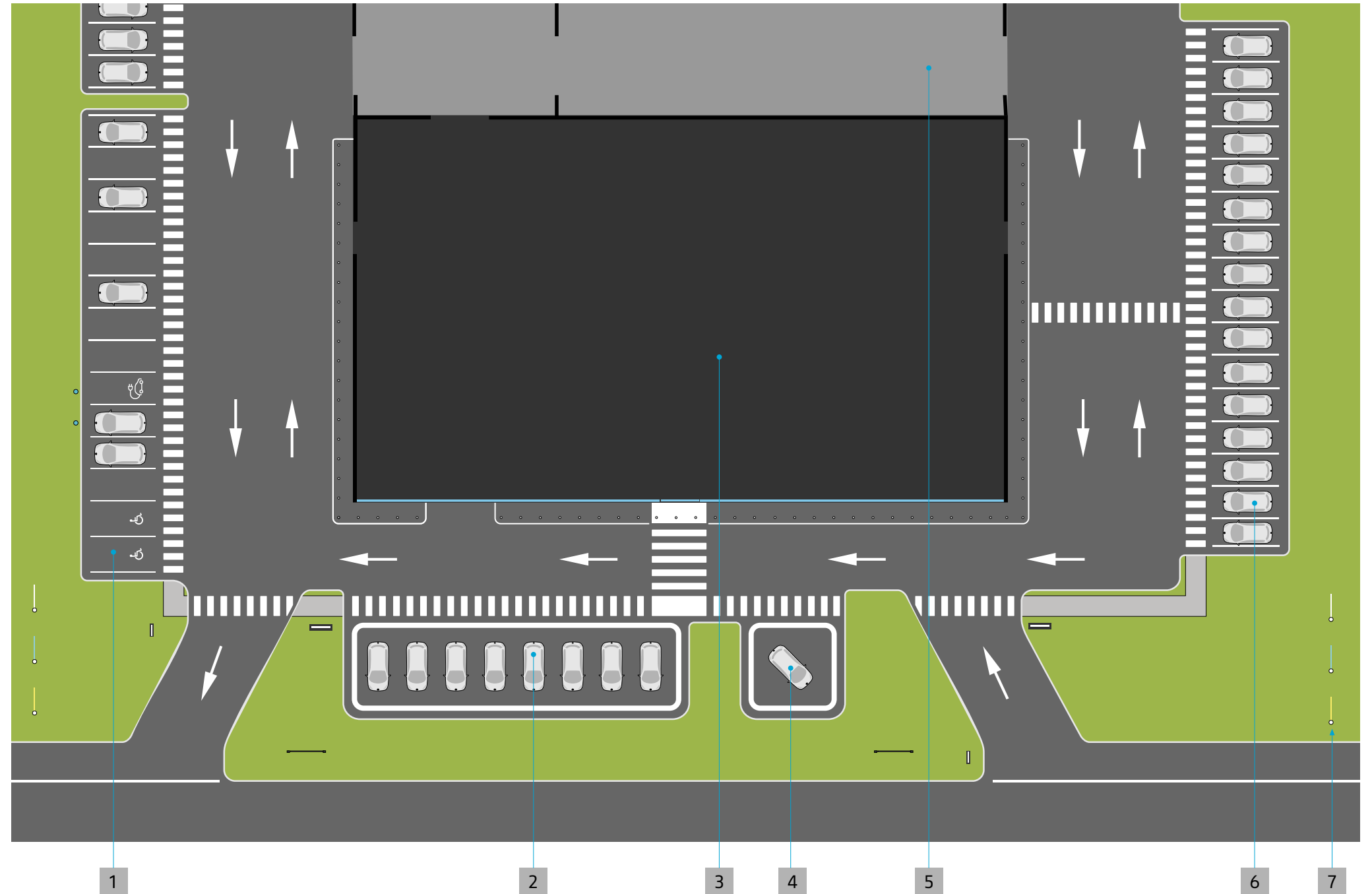

4.5 Showroom

WHY?

The organizational principles and showroom infrastructures of stand-alone sites are identical to those of integrated showrooms.

Components in common are:

- dark grey tiles,
- RAL 9010 white walls,
- RAL 7021 dark grey lacquered aluminum window frames and white glass window.

HOW?

- 1 Upon entering the exhibition, the promise panel presents the elements of the customer promise.
- 2 Due to its orientation and continuity, the central bay guides customers as they move around the showroom and encourages the organization of vehicles around this axis.
- 3 The brand wall features the full renew signature. It is located on the back wall of the exhibition in line with the central bay.
- 4 The vehicles are arranged perpendicular to the central bay. They are grouped according to the different segments of the renew offer.
- 5 The sales offices are located at the back of the exhibition, decorated with a large-format wall display.

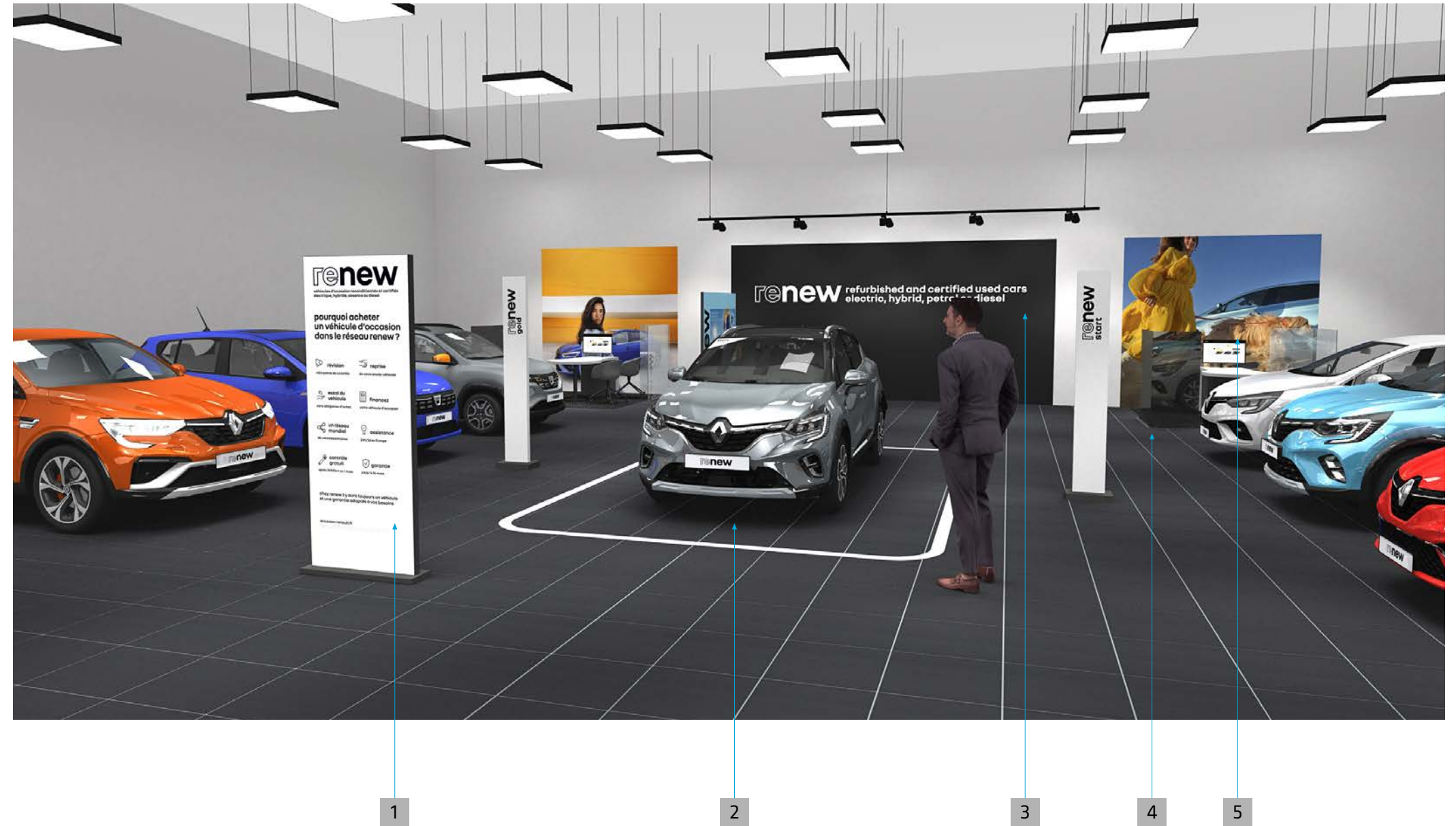

4.6 Component table

A FLEXIBLE SYSTEM

In order to provide a consistent customer experience, renew sites include mandatory components.

The optional components make it possible to personalize the offer of each site according to its needs and specificities.

WARNING

This table presents the main lines of use of the different families of components.

Please refer to the detailed description of each of the configurations which are available depending on the number of vehicles present on the site.

* Arch and area mast should not be used together.

** Except in special cases, the flagshig zone must not be used when an exhibition area exists on the site.

*** Number of vehicles present in each zone.

- mandatory
- optional
- not applicable

		Components	from 5 to 15 vehicles ***	> to 15 vehicles ***
La signalétique d'identification	renew flags		■	■
	Arch *		■	■
	Area mast *		■	□
Infrastructure	Dedicated customer parking		■	■
	Independent access		■	■
Components of the outdoor exhibition	renew flagship zone		■	■
	Priority exposure areas		■	■
	Markings of exhibition areas		■	■
	Customer promise panel		■	■
	Generic banners		■	■
	Lighting masts		■	■
	Promotional tarpaulin		■	■
	renew sales area		□	□
Showroom facade	renew facade marking		■	■
	renew entrance marking		■	■
	Customer promise panel		■	■
Showroom components	renew brand wall		■	■
	Customer promise panel		■	■
	Identification box		□	□
	Area panels		■	■
	renew sales offices		■	■
	2x2 POS		■	■

5

EXTERIOR COMPONENTS

5.1 Directional signage

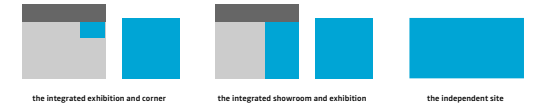

WHY?

Directional signage is installed to mark customer routes from the area around the site to the reception areas.

HOW?

It uses the following elements:

- 1 The directional sign.
- 2 Entrance/exit panels (option).
- 3 The car park identification sign (option).
- 4 The parking terminal (option).

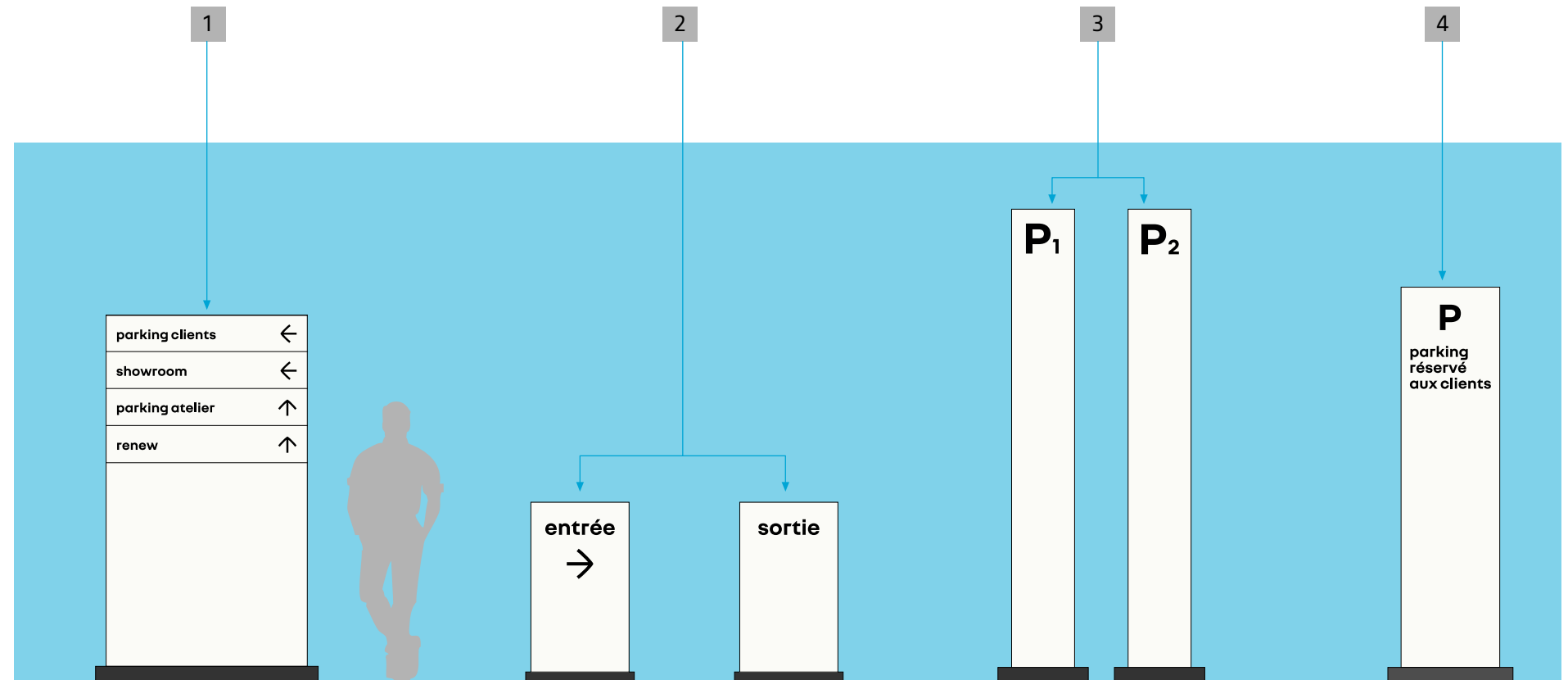

NOTE

For any technical information relating to Renault components, refer to the Specifications for each component.

For any instructions on the use of Renault components, refer to the Renault retail architecture guidelines.

5.2 Directional sign

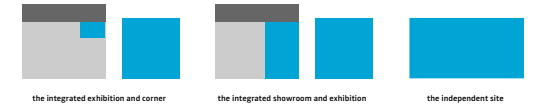

WHY?

In the case of a car park dedicated to renew customers, the words "parking renew" are used, from the outskirts, on the faces of the directional signs in order to guide customers to this specific car park.

HOW?

- 1 The words "parking renew" appear on the face of the directional terminals, written in **nouvel'R bold** typography.

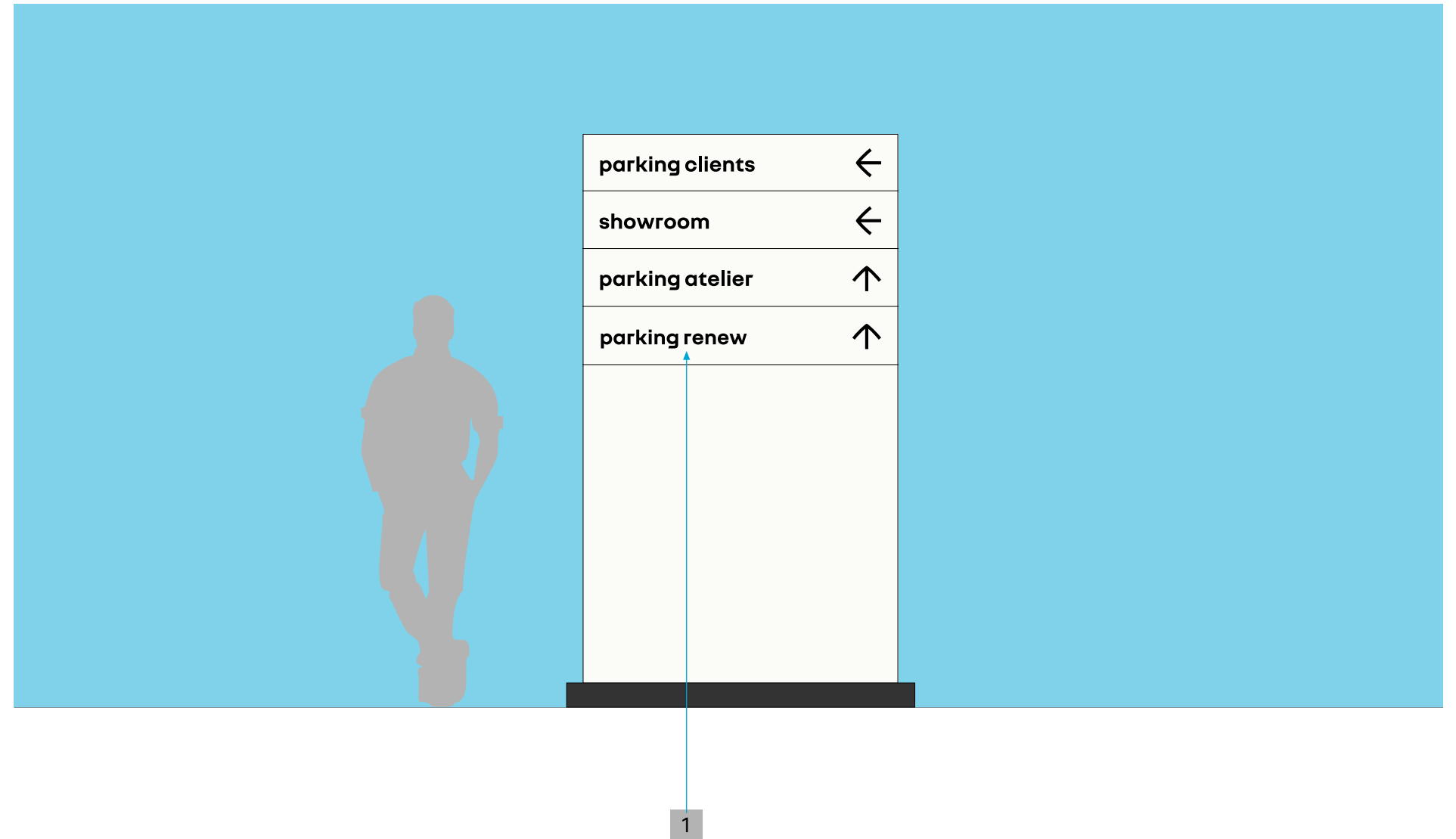

NOTE

For any technical information relating to Renault components, refer to the Specifications for each component.

For any instructions on the use of Renault components, refer to the Renault retail architecture guidelines.

5.3 Customer car park

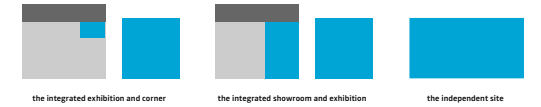

WHY?

The renew customer car park is preferably located in front of the outdoor exhibition area.

It is identified by signage and separated from other parking spaces.

HOW?

- 1 Parking spaces are demarcated by 100mm wide RAL 9003 white strips .
- 2 The recommended dimensions of 2300 x 5000mm are identical to those of other customer car parks.
- 3 Each location reserved for People with Reduced Mobility is identified by a pictogram.
- 4 Parking signs (optional) are located on either side of the car park helping to identify it.

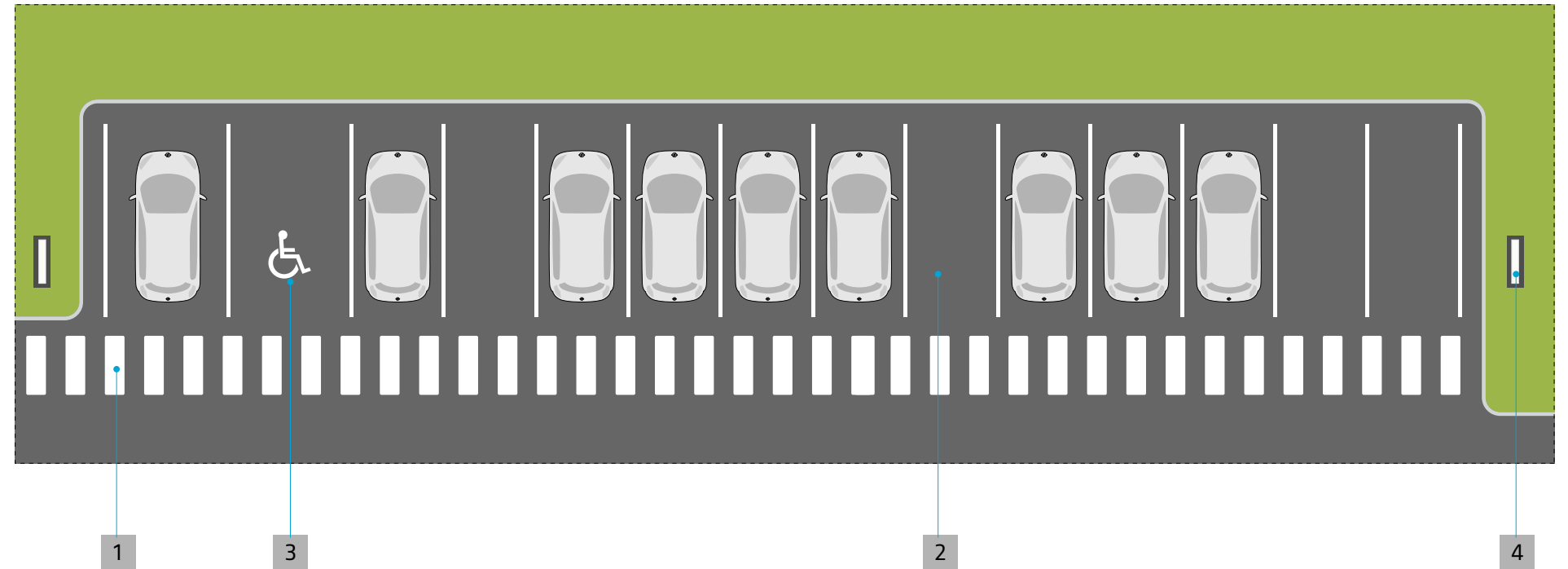

NOTE

The Person with Reduced Mobility locations have dimensions and color codes regulated according to the country.

5.4 renew flags

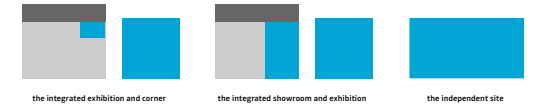

WHY?

The flags have a strong visual impact from a distance and allow rapid identification of the site. They mark the geographical limits of the affair.

HOW?

- 1 Renault flags are used in corners and integrated renew sites in the same manner as those used for Renault Stores sites. The renew outdoor exhibitions are identified by a series of renew flags installed in the order shown opposite.
- 2 Autonomous renew sites are identified by 2 series of renew flags (in colors different from those used on integrated sites) installed in the order shown opposite.

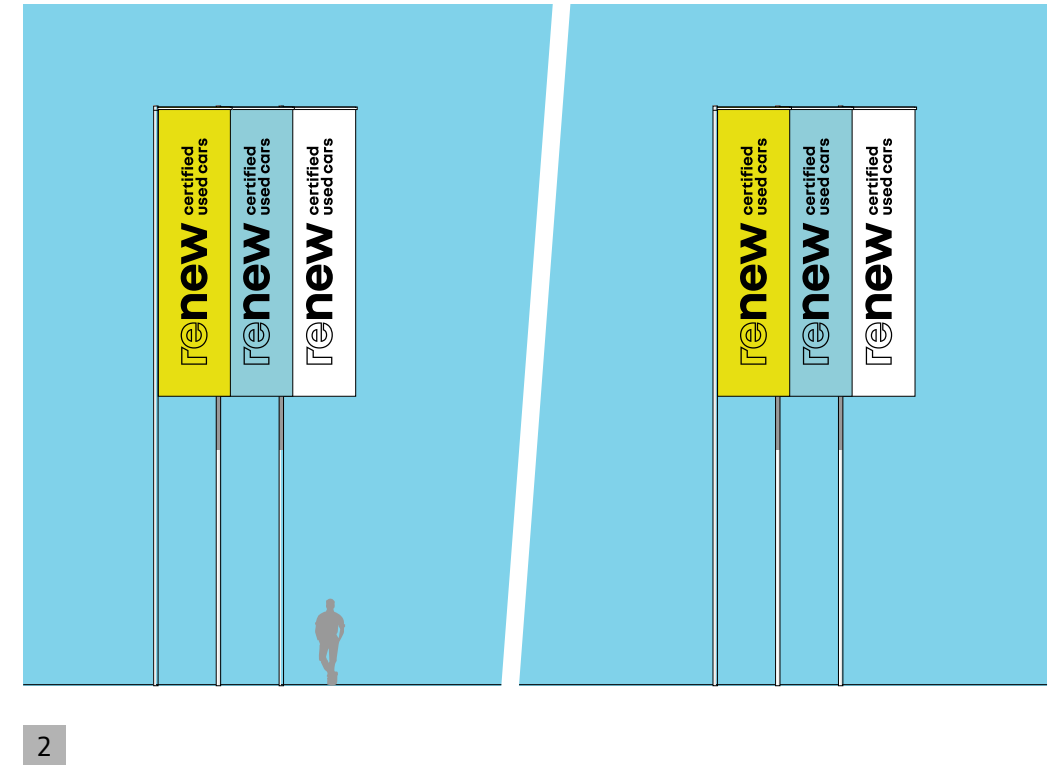
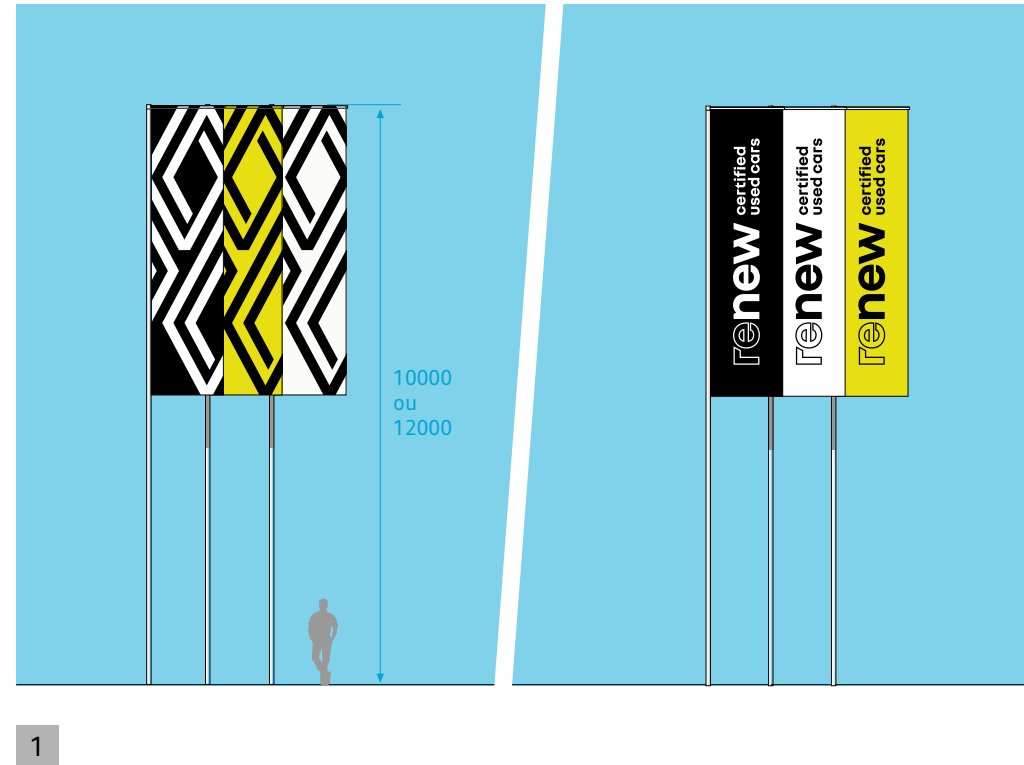

5.5 Arch sign

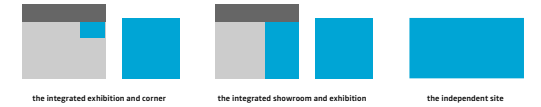

WHY?

The arch identifies the exterior exhibition areas.

HOW?

Located at the entrance to the exhibition area, it is positioned in the axis of the central span.

- 1 It may have a back identical to the front, in the case where the arch benefits from good visibility from both sides.

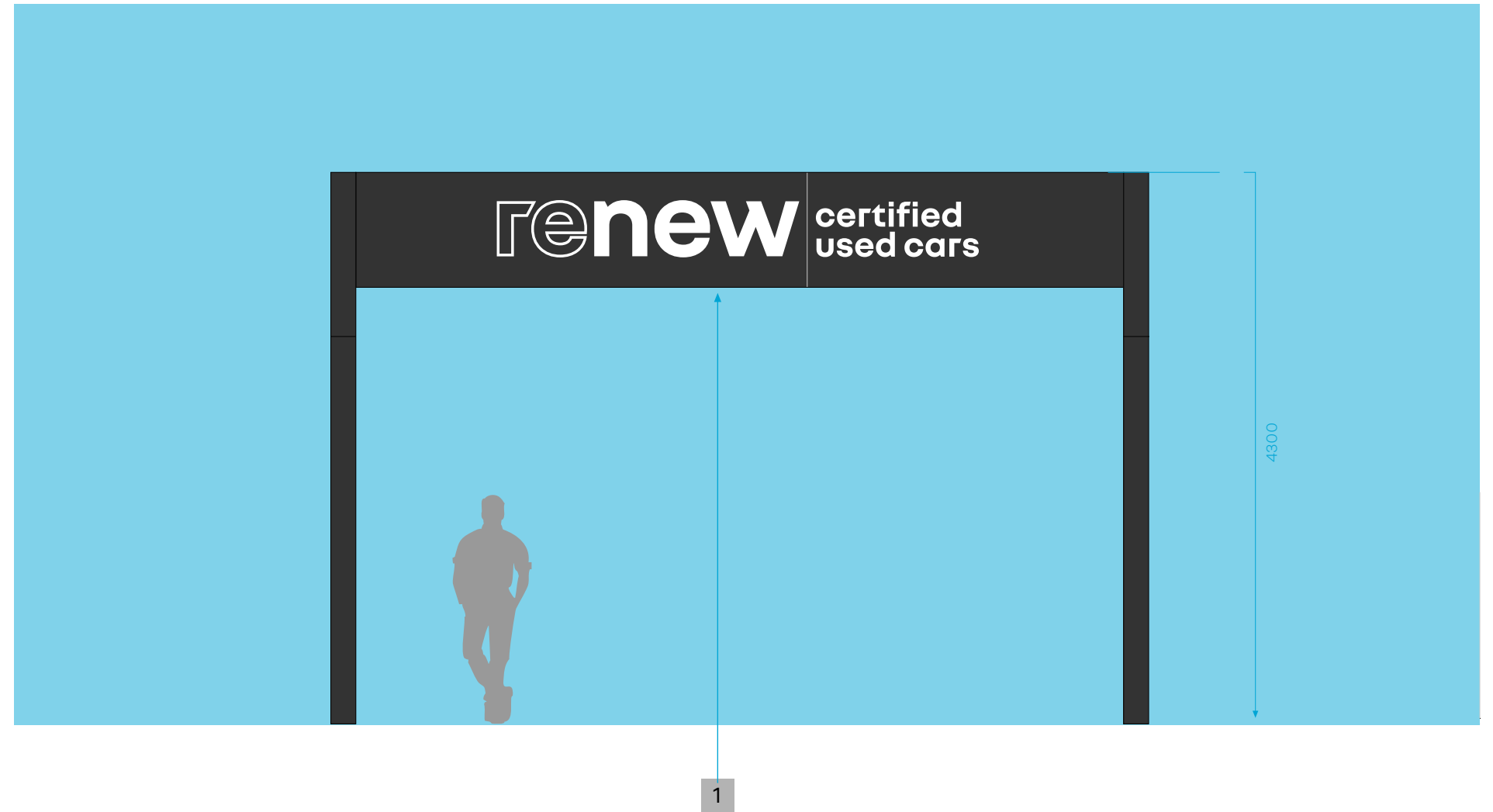

5.6 renew area mast

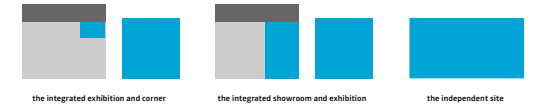

WHY?

In the context of small exhibition areas (less than 15 vehicles on display) the renew area mast replaces the signage arch when it cannot be used.

The area mast is installed parallel to the facade.

The illuminated front side is always oriented towards the main road.

HOW?

- 1 The area mast has a dark grey background on which the renew signature is present.
With a height of 4 m, it is luminous and double-sided.

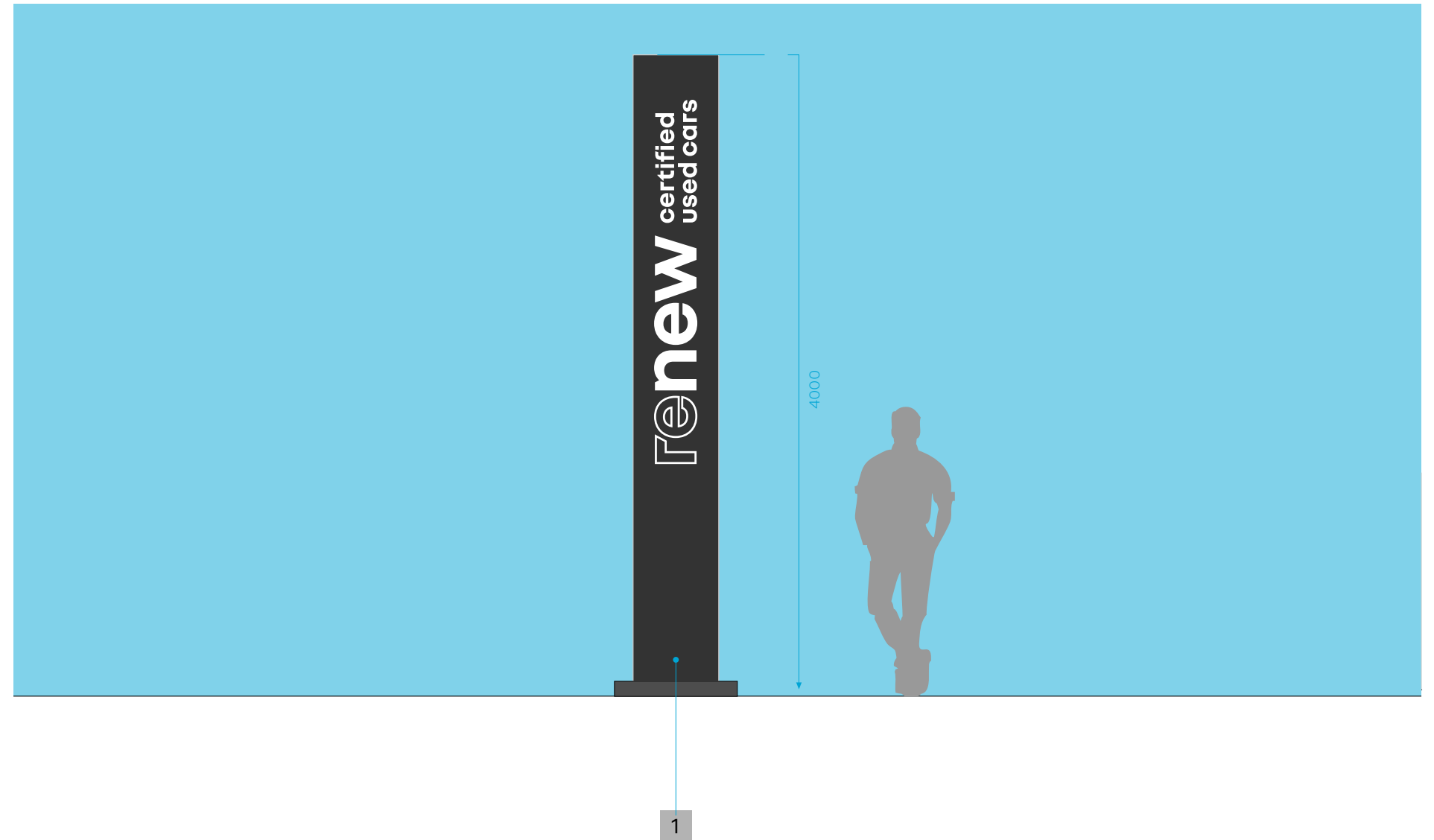

5.7 Customer promise panel

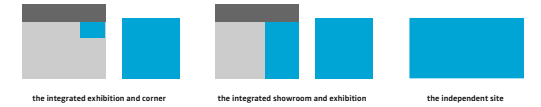

WHY?

This medium displays a message presenting the customer promise.

This element is located in front of the first vehicle present in the central bay of the outdoor exhibition area.

The content must be adapted by the country with the approval of the Corporate Marketing Department.

HOW?

- 1 The front panel presents the customer promise.
- 2 The rear side is uniformly painted in dark grey.

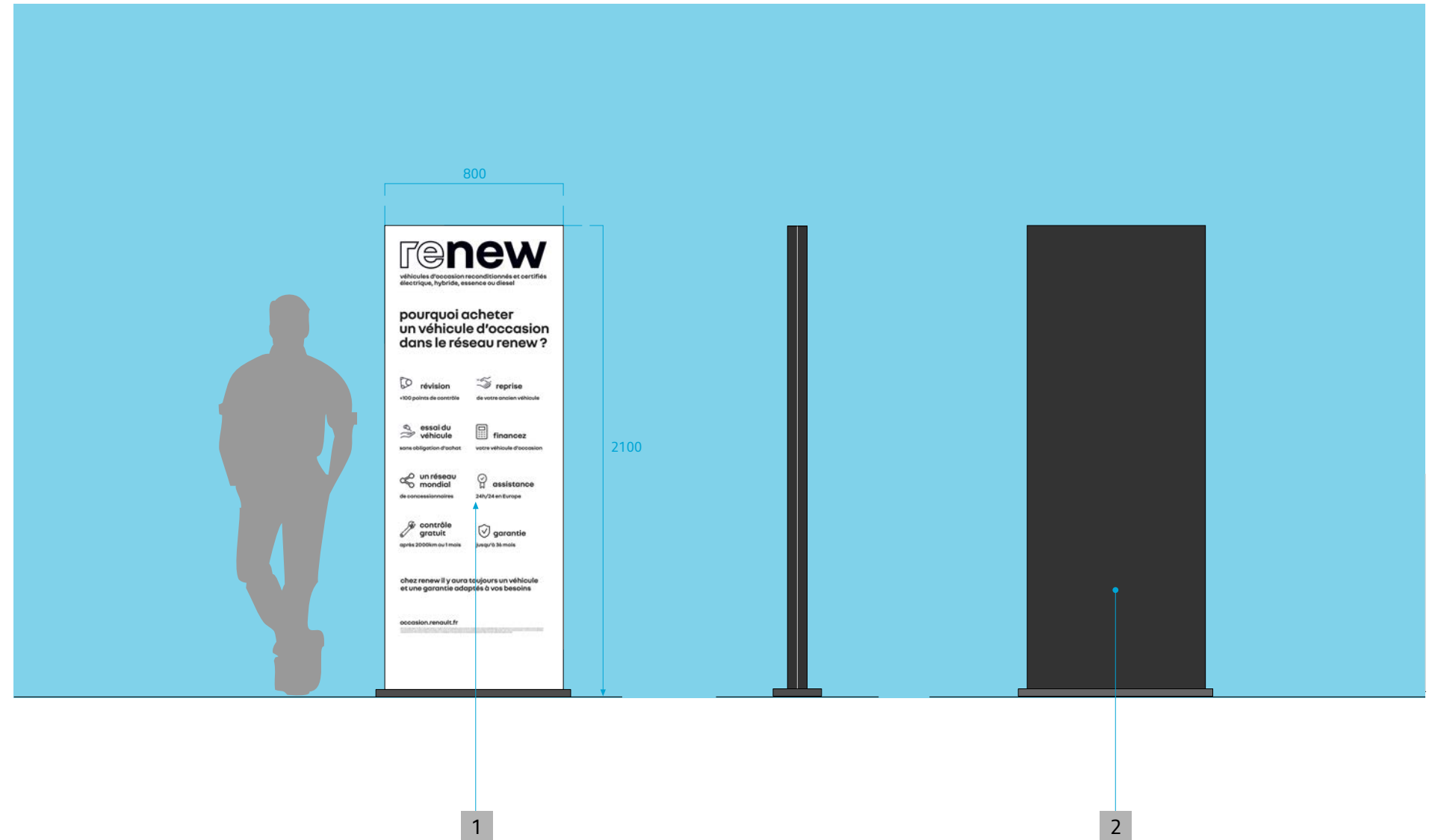

NOTE

The visuals of promotional materials evolve according to the renewal campaigns. Contact Renault Global Marketing to obtain the latest versions.

5.8 Generic banners

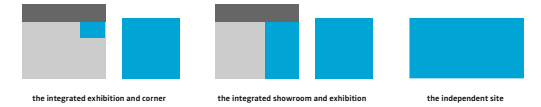

WHY?

The purpose of the generic banners is to organize and mark the renew zone according to the different segments making up the offer.

HOW?

4 segments are possible.

These elements are located in front of the priority exhibition areas on either side of the central span.



NOTA

Ces éléments remplacent les précédents panneaux de travée.

5.9 Promotional tarpaulin

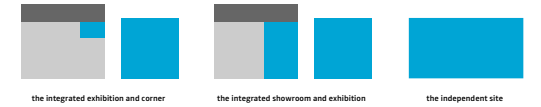

WHY?

The renew promotional banner is located near the outdoor exhibition area so that it is visible from the main traffic axis.

HOW?

- 1 The promotional tarpaulin includes a visual printed on a polyester tarpaulin.
- 2 A tension system incorporated into the posts optimizes the visibility of the visual and makes it easier to change the tarpaulin.



NOTE

The visuals of promotional materials evolve according to the renewal campaigns. Contact Renault Global Marketing to obtain the latest versions.

5.10 Lighting masts

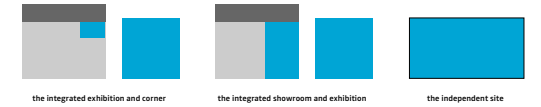

WHY?

The lighting masts make it possible to reinforce the central axis of the exhibition, to highlight the vehicles appearing in the central bay and to illuminate the adjacent pedestrian circulations.

HOW?

- 1 View from the interior side
- 2 View from the exterior side
- 3 Front view

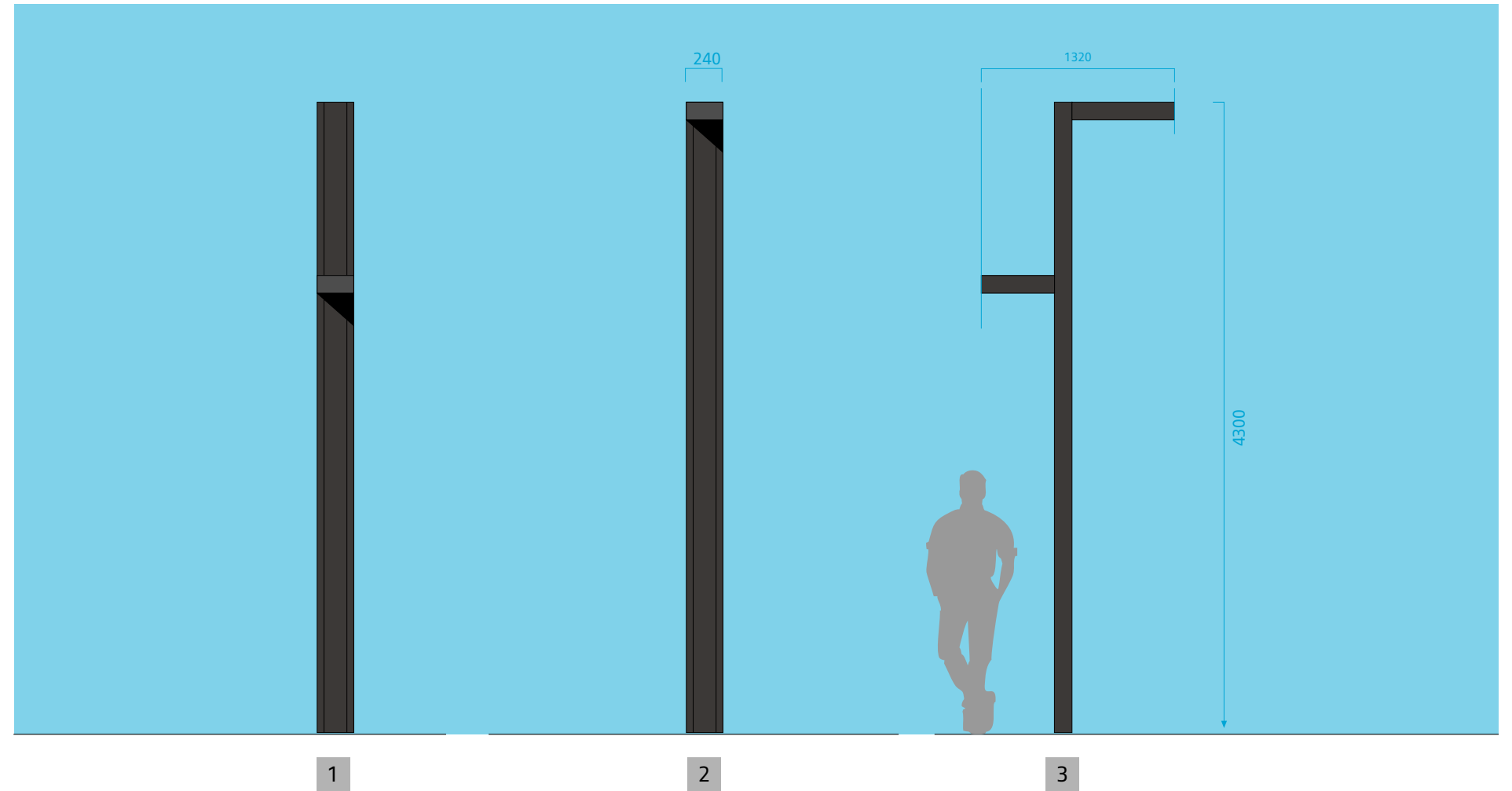

5.11 renew sales area

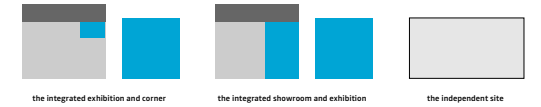

WHY?

When it exists, the sales space is located in the axis of the main circulation of the outdoor exhibition.

It takes the form of a modular building whose size is adapted to the number of renew advisors present in the exhibition area.

HOW?

- 1 A dark grey fascia bears the renew signature to identify the sales area.
- 2 The panel to the left of the entrance allows to communicate about the renew customer promise.



NOTE

The visuals of promotional materials evolve according to the renewal campaigns. Contact Renault Global Marketing to obtain the latest versions.

5.12 Entrance markings

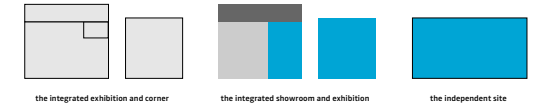

WHY?

When it exists, the sales space is located in the axis of the main circulation of the outdoor exhibition.

It takes the form of a modular building whose size is adapted to the number of renew advisors present in the exhibition area.

HOW?

- 1 A light box is located above the main entrance door to access the renew showroom.
- 2 Adhesive markings.
- 3 Horizontal stripes.
- 4 Customer promise entrance marking (visual presented for illustration purposes).

NOTE

The visuals of promotional materials evolve according to the renewal campaigns. Contact Renault Global Marketing to obtain the latest versions.



5.13 renew sales area • interior design

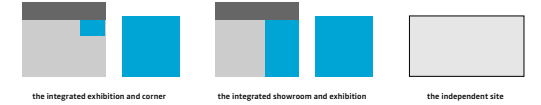

WHY?

The layout of the modular building includes at least a waiting area, the offices of the renew sales advisors, the renew communication elements and a hot or cold drinks dispenser.

In addition, a toilet block can be integrated into the space.

As a reminder, the customer promise is present outside the building at the entrance door.

HOW?

- 1 A black wall has the full renew signature.
Refer to the specifications of the renew elements for adaptation of the dimensions of the renew signature on black wall according to available space.
- 2 The waiting area has grey armchairs combined with a black coffee table.
- 3 The sales advisors' offices have the same layout elements as the offices present in the showrooms (large format visual, grey table and chairs, large format wall screen, etc.).
- 4 Hot and cold drinks dispensers are located near the waiting area.
- 5 A fully glazed partition ensures confidentiality of exchanges between customers and sales advisors.
- 6 A wall-mounted version of the 2x2 renew POS is installed opposite the wall bearing the renew signature.

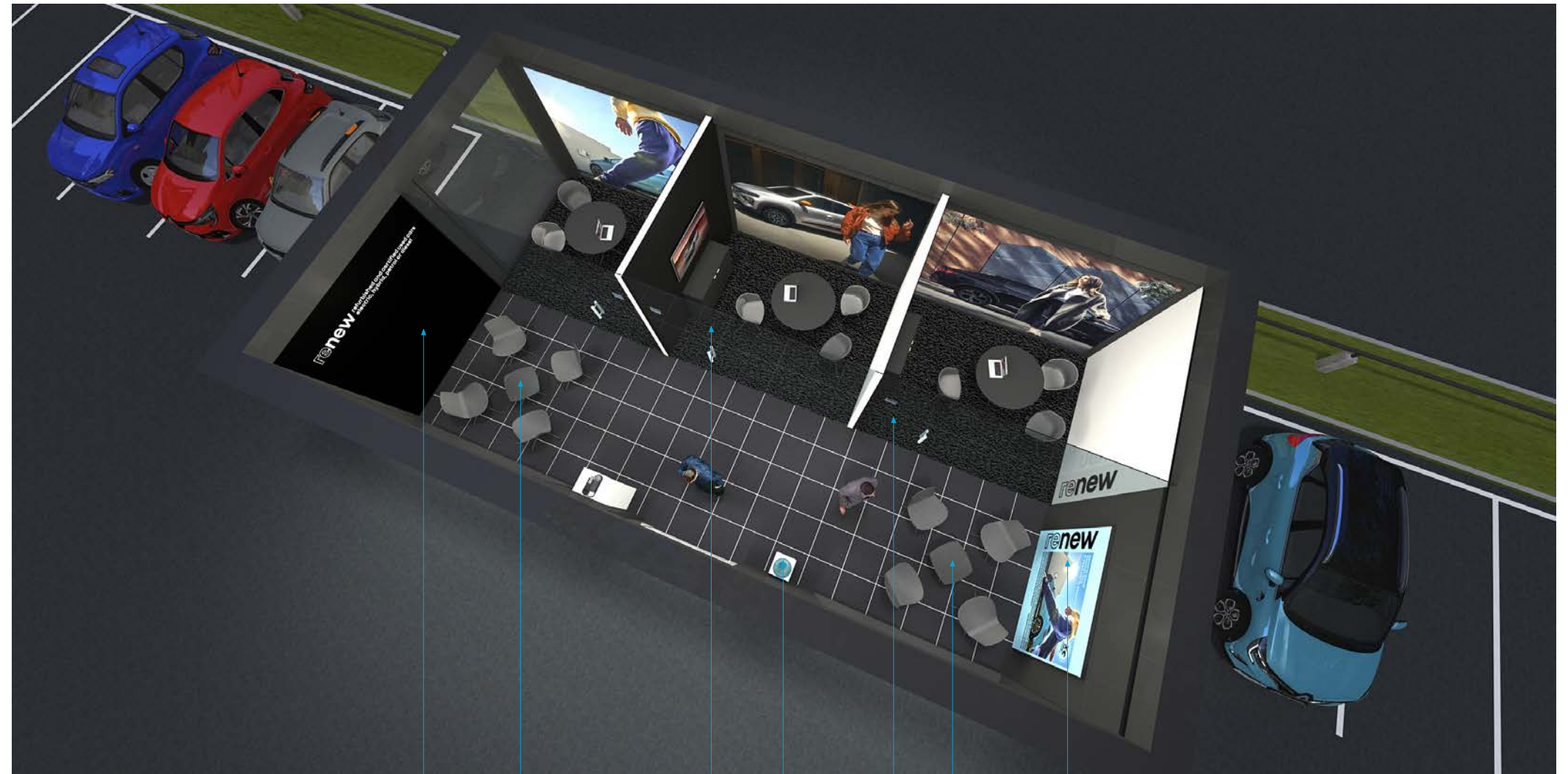

5.14 The renew flagship zone of less than 5 vehicles

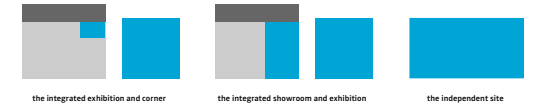

WHY?

In the event of a lack of space near a site, it will be possible to present in a reduced exhibition area comprising 1 to 5 used vehicles.

HOW?

The flagship renew zone can be set up in front or to the sides of the sites but never in front of the new vehicles showroom.

It uses the following components:

- 1 The area mast.
- 2 The lighting mast (optional).
- 3 The promotional tarpaulin.



5.15 Integration of the renew flagship zone of less than 5 vehicles

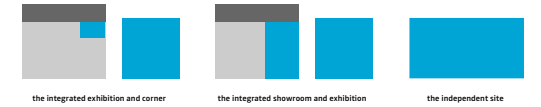

WHY?

The exterior exhibition areas create an important visual appeal thanks to the exhibition of vehicles representative of the brand's current events as well as those on test.

These are located in front of the new vehicles showroom.

Where applicable, the flagship renew zone is aligned with the other outdoor exhibition areas.

HOW?

- 1 Preferably, the renew flagship zone is located on one side of the showroom.
- 2 The renew area must identify the flagship zone.
- 3 The ground marking demarcates the renew flagship zone which can include 1 to 5 vehicles.
- 4 The pedestrian path connects all the exhibition areas to the new vehicles showroom (or used vehicles when an access door exists).
- 5 Typical configuration of a renew flagship zone with 1 vehicle.
- 6 Typical configuration of a renew flagship zone with 5 vehicles.

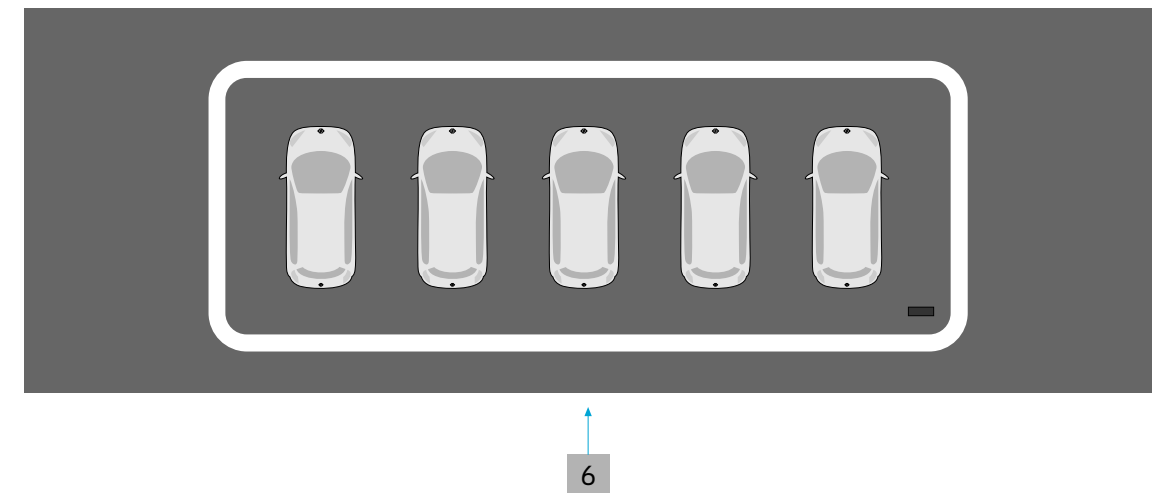
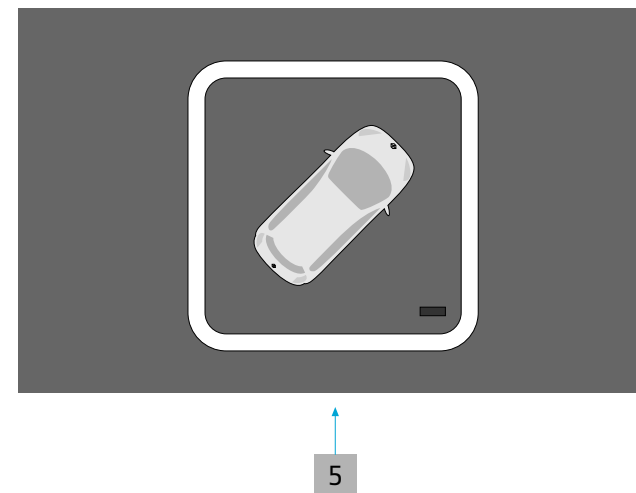
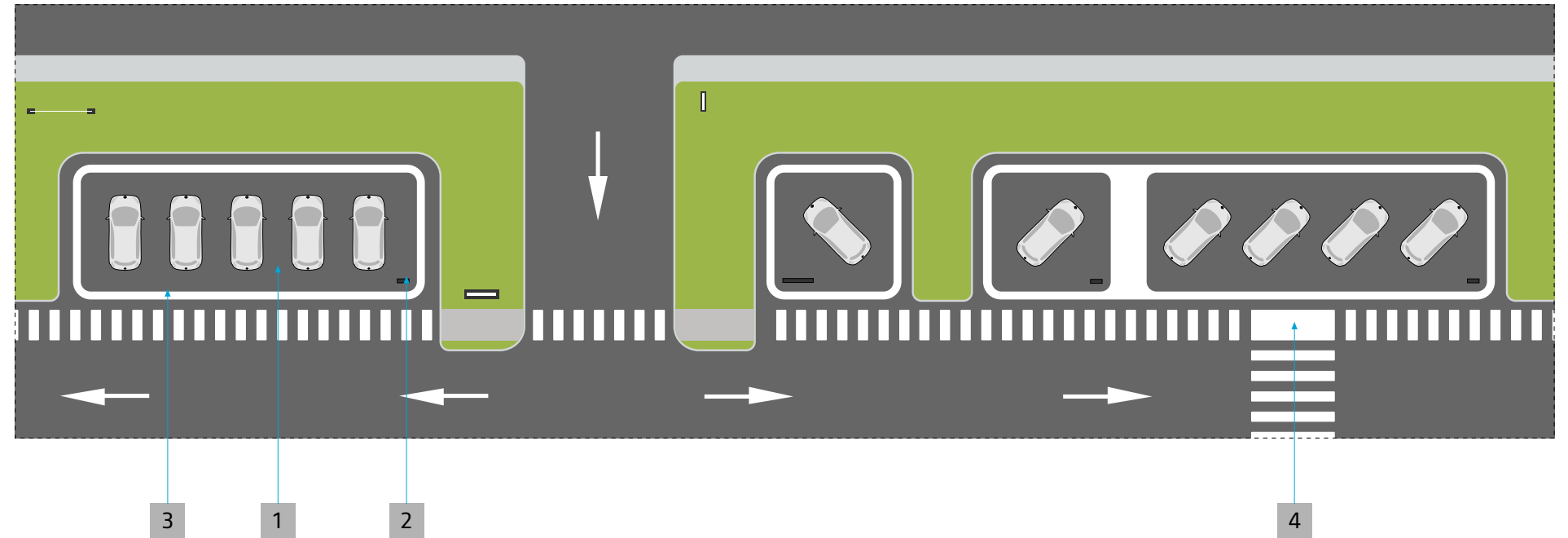

6

INTERIOR COMPONENTS

6.1 Interior identification box

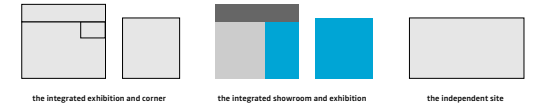

WHY?

When the renew showroom is integrated into a Renault showroom, a suspended light box is installed at the edge of the used vehicle exhibition.

HOW?

The box is installed in the axis of the entrance and the central bay at the edge of the renew showroom.

The top of the box is positioned 4 m from the ground.

It is double-sided:

- 1 On the front, it bears the signature renew,
- 2 On the back, it bears the words "new vehicles showroom".



6.2 renew brand wall

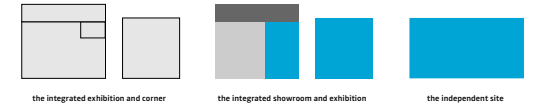

WHY?

The brand wall identifies the renew showroom.

It features the renew signature with the advertising customer promise in white reserve on a RAL 9005 matt black background.

HOW?

It is located on the back wall of the exhibition in line with the central bay.

The signature is centered in the width of the wall, the latter being able to have 4, 6 or 8m of standard length.

The standard height is 3m.

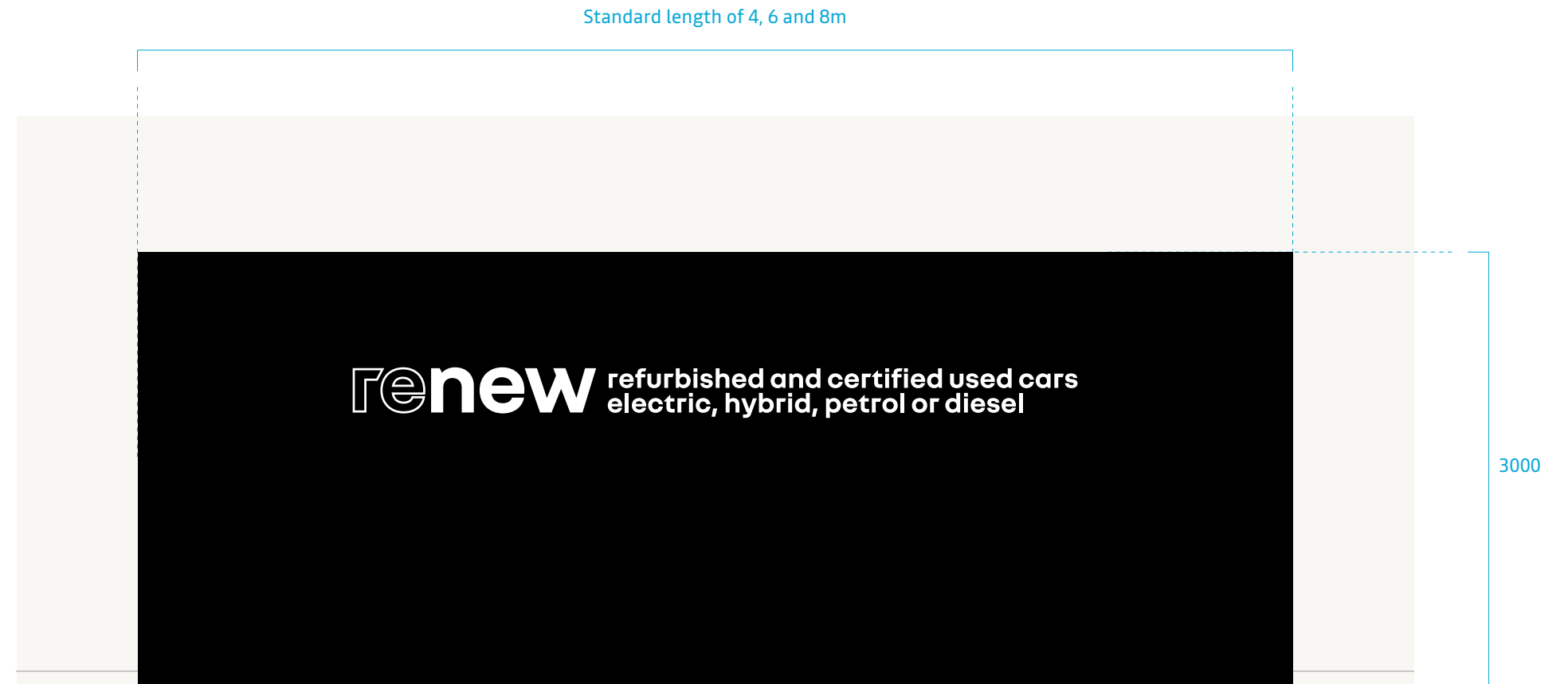

6.3 renew brand wall • length adaptation

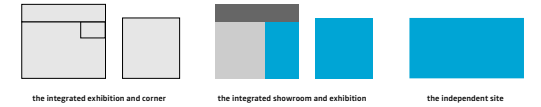

WHY?

Depending on the dimensions of the exhibition, it may be necessary to adapt the length of the renew brand wall.

HOW?

Between 4 and 6m in length, the complete renew signature has a height of 205mm.

Beyond 6m, the height of the signature is 305mm

- 1 RAL 9005 black wall in matte finish, (fine textured canvas or paint for easy cleaning).
- 2 renew signature with full customer promise, centered in the width of the wall, made from a cut of 3mm thick white matt PMMA, fixed to the wall by gluing.
- 3 Back wall of the showroom painted in RAL 9010 matt white.

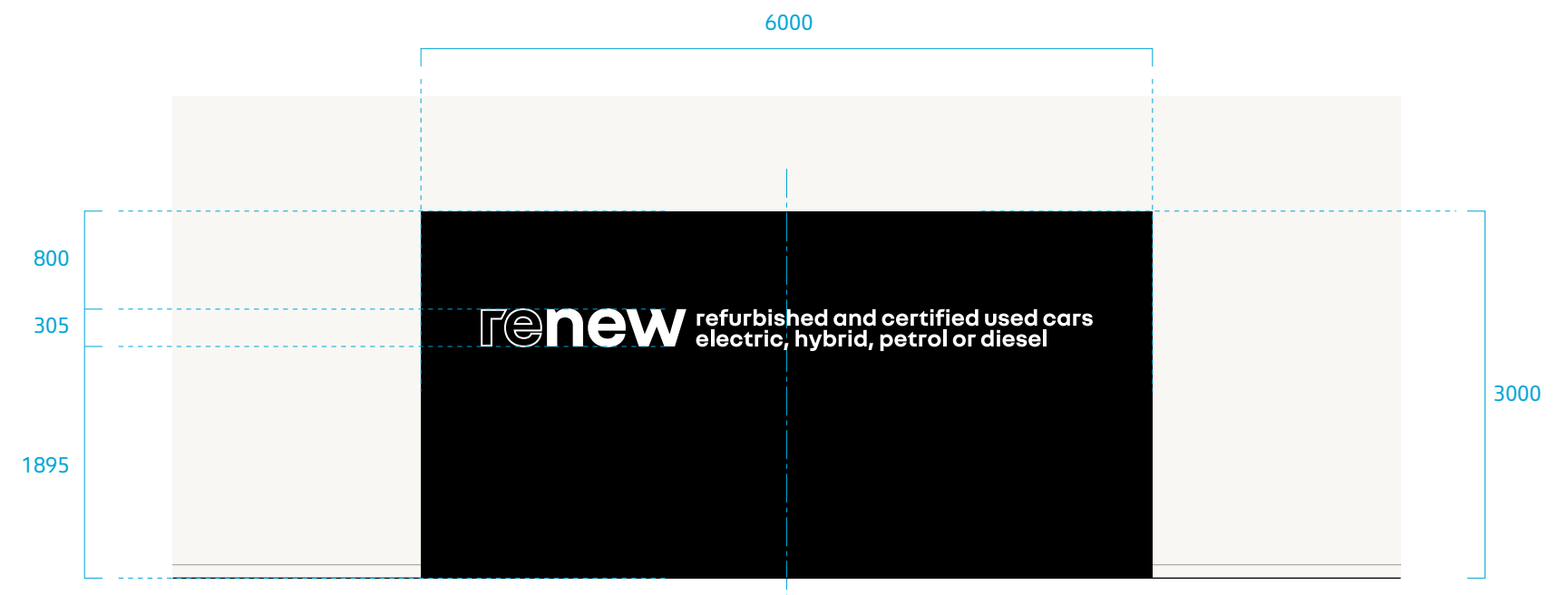
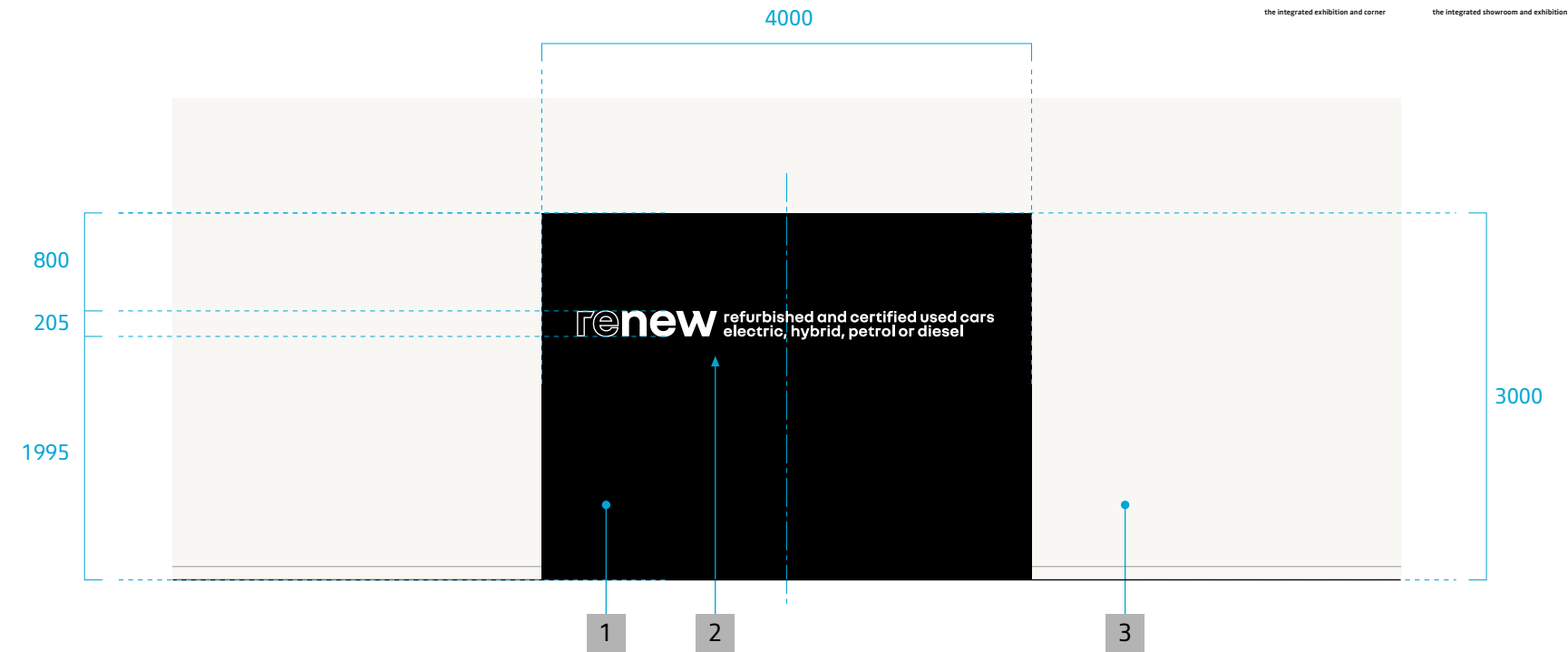

6.4 Area panels

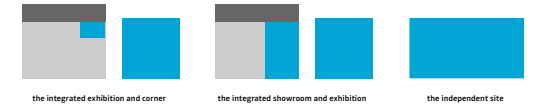

WHY?

The area panels respond to a logic of segmentation and organization of the renew showroom.

HOW?

The area panels are installed in the axis of each exhibition module, on either side of the central span.

Their front face is oriented towards the entrance to the showroom.

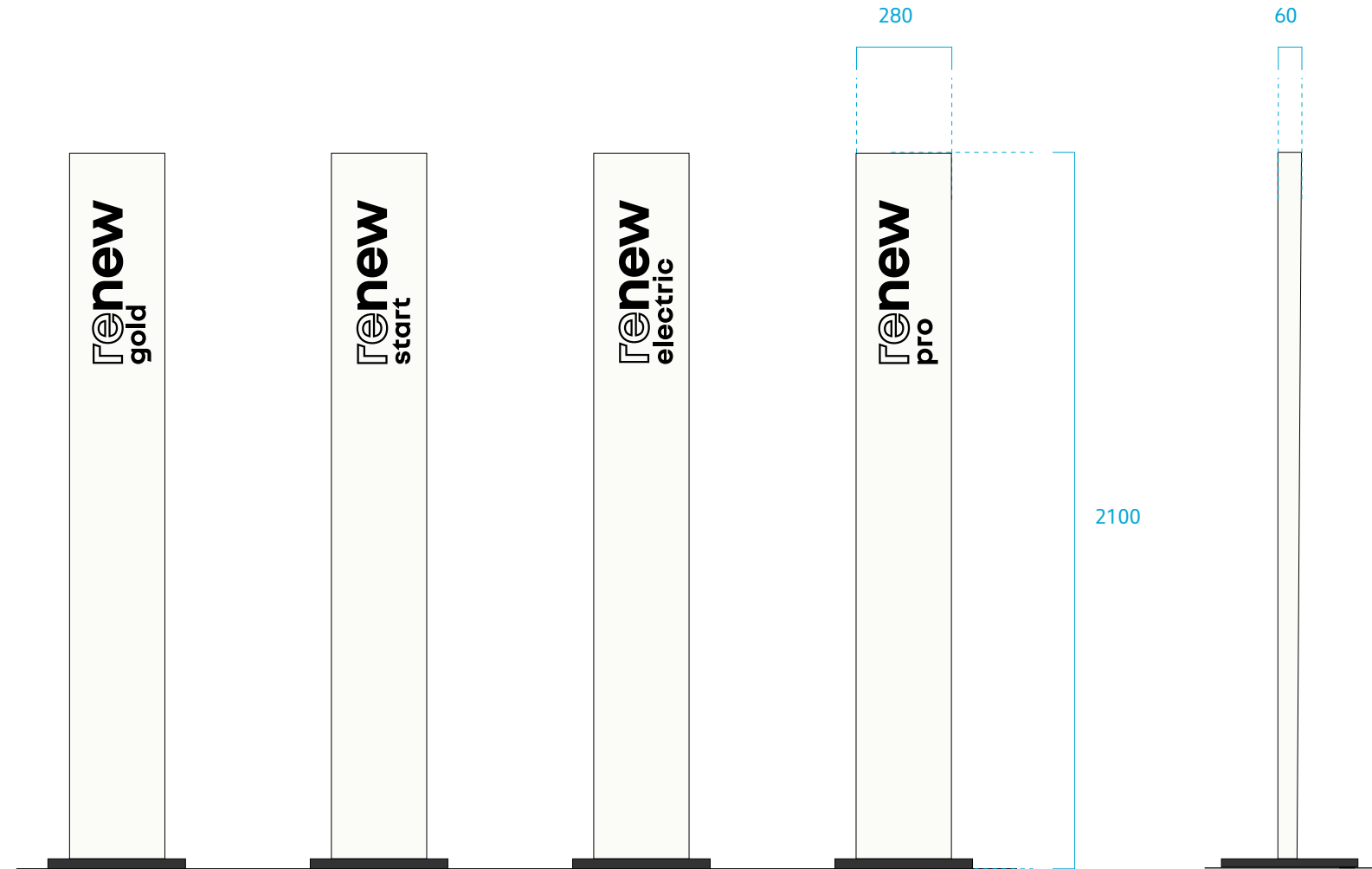

6.5 2x2 POS

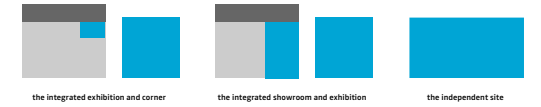

WHY?

The 2x2 communication support allows you to develop the content of the renew customer promise.

It is updated periodically.

This 2x2 POS is present in all configurations of renew showrooms.

It is also present in the renew corner (see next page).

HOW?

The 2x2 communication support is installed in front of the renew branded wall, preferably on the left side and perpendicular to the back wall.

- 1 Generic life style visual.
- 2 Promotional visual.

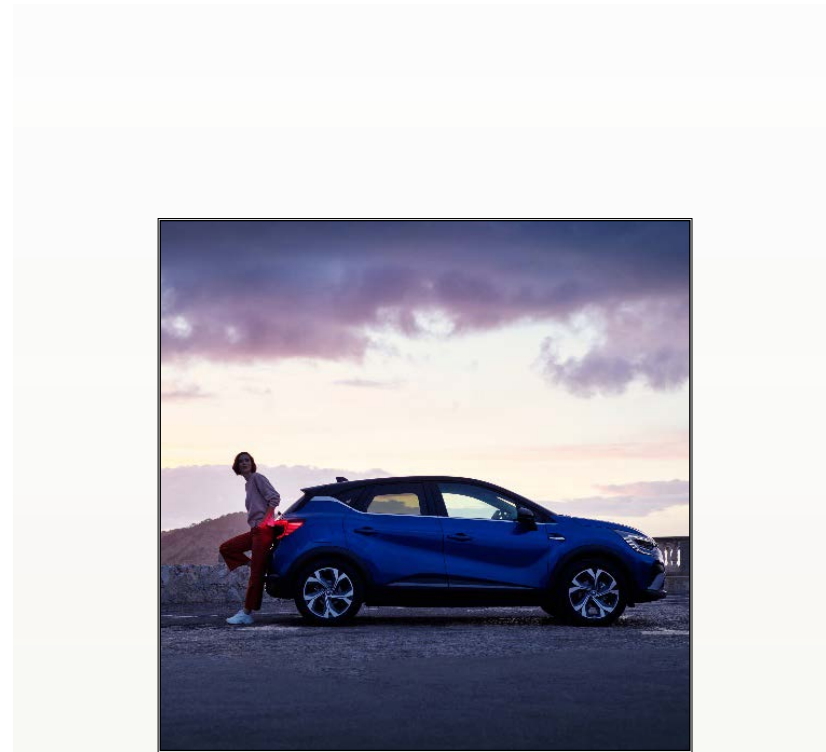

1

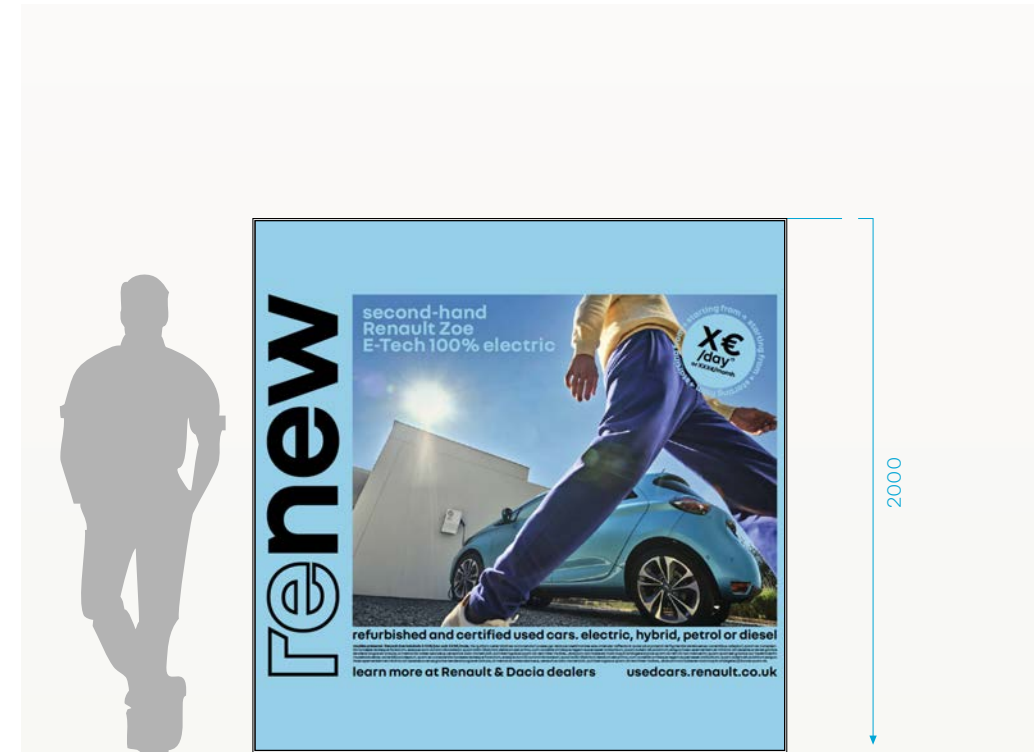

2

NOTE

The visuals of promotional materials evolve according to the renewal campaigns. Contact Renault Global Marketing to obtain the latest versions.

6.6 renew corner

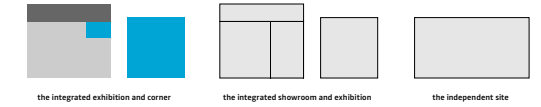

WHY?

Depending on the position in the showroom and customer flow, the location of the different components evolves.

HOW?

- 1 The customer promise totem-kakemono is located on the side of the vehicle, to the right or left of the vehicle, depending on customer flow.
- 2 The 2x2 renew POS is located in the background behind and in line with the vehicle.
- 3 Customers can go around the vehicle with at least 1.40m of clearance.
- 4 The renew corner can be placed against the back wall of the showroom, possibly in a corner of the showroom or in the middle of the showroom.

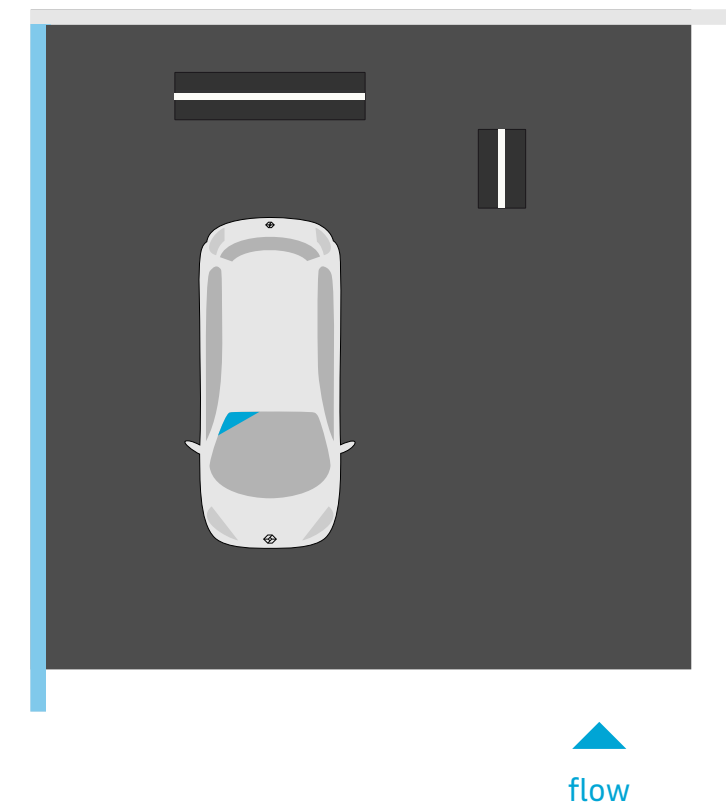
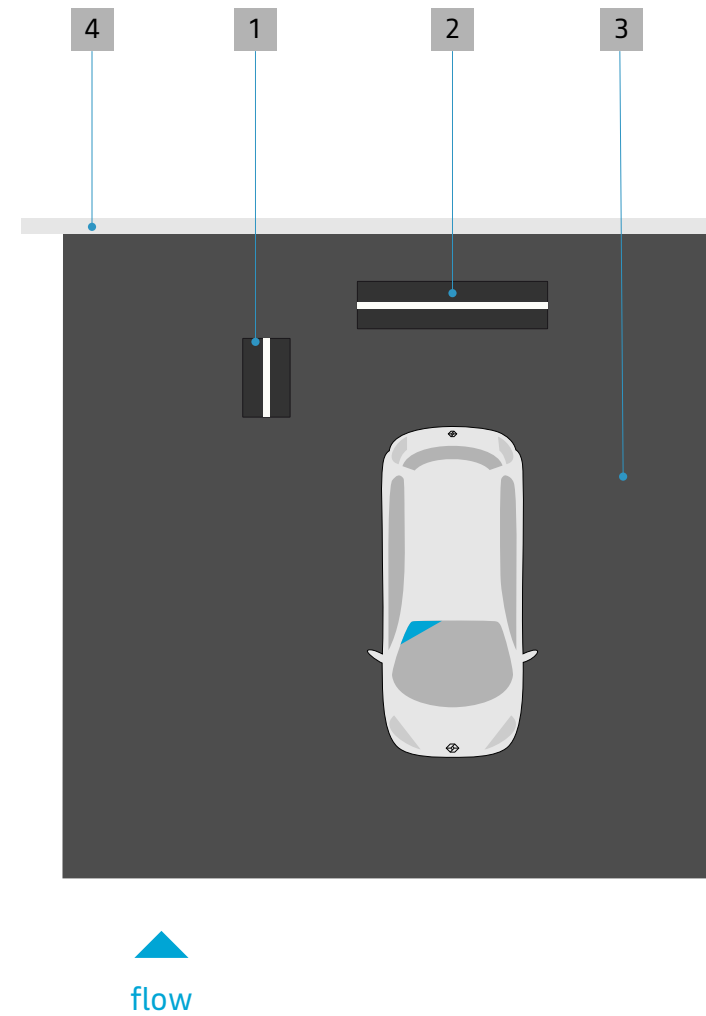

6.7 renew totem-kakemono

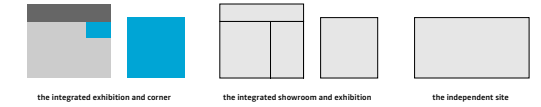

WHY?

The totem-kakemono makes it possible to present the customer promise in the renew corner integrated into the new vehicles showrooms.

HOW?

- 1 Front of the kakemono presenting the statement of the customer promise.
- 2 Back of the kakemono with a visual illustrating the content of the customer promise.



1

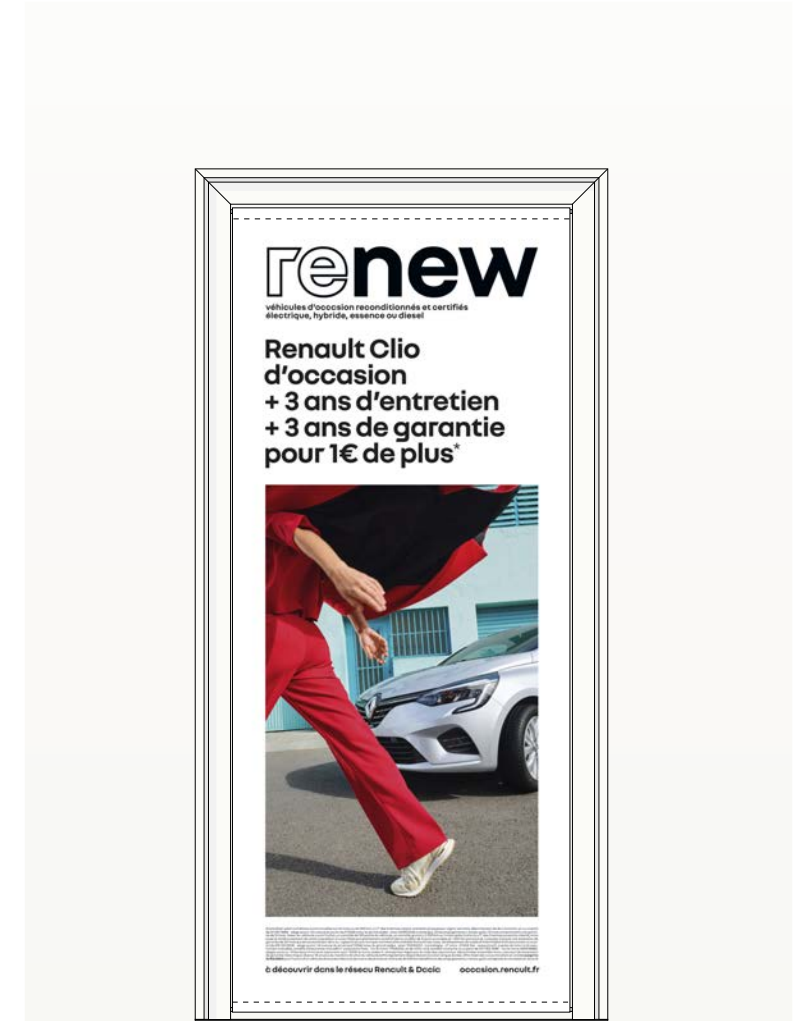

2

NOTE

The visuals of promotional materials evolve according to the renewal campaigns. Contact Renault Global Marketing to obtain the latest versions.

6.8 renew plates



WHY?

The renew plates identify used vehicles with the renew brand, distinguishing them from new vehicles at first glance.

These plates are mandatory for all vehicles presented in the corners, renew showrooms as well as vehicles presented in the central bays and priority exhibition areas of the exterior areas.

HOW?

- 1 The plate with the renew signature is present on the front of used vehicles.

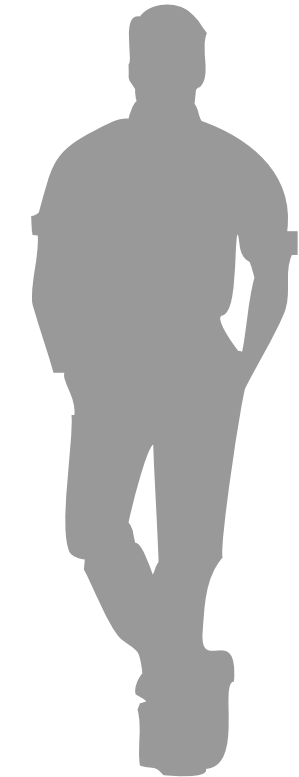

1



NOTE

The visuals of promotional materials evolve according to the renewal campaigns. Contact Renault Global Marketing to obtain the latest versions.

6.9 renew windshield stickers

WHY?

Windshield stickers allow you to identify the offer that each of the vehicles on display benefits from.

These stickers are available according to the 4 segments of the renew offer, of which they display the identification color.

Size: 21 x 29.5 cm.

HOW?

- 1 The stickers are positioned in the upper left corner of the windshield of each used vehicle.

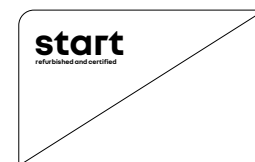

NOTE
The visuals of promotional materials evolve according to the renewal campaigns. Contact Renault Global Marketing to obtain the latest versions.

6.10 renew price poster



WHY?

Price labels display the price and main characteristics of each vehicle on display.

They are available according to the 4 segments of the renew offer, whose identification color they display.

This display is mandatory.

HOW?

- 1 The A4 format price labels are positioned behind the windshield of each used vehicle, arranged on a personalized support attached to the rearview mirror so that the information is visible to customers from the outside.



NOTE
The visuals of promotional materials evolve according to the renewal campaigns. Contact Renault Global Marketing to obtain the latest versions.

6.11 Open offices of renew advisors

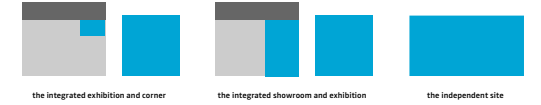

WHY?

One or more renew advisors may be present in the new vehicles showrooms.

To welcome customers, they have semi-open offices located, where appropriate, near the renew corner.

HOW?

- 1 Side walls create the privacy needed in these open spaces. The clear wall has the renew signature in reserve in the frosted decor.
- 2 The dark colored wall is always located behind the renew advisor, the light wall being oriented towards the entrance to the showroom.
- 3 The furniture combines a dark grey storage box with a white top to welcome the customer in a friendly atmosphere.
- 4 The chairs for customers and sales advisors are the same color.
- 5 A screen is integrated into the furniture presenting the renew offers to customers.
- 6 The dark grey carpet demarcates and provides comfort to the area.



2

5

3

6

4

1

6.12 Open office configurations (1)

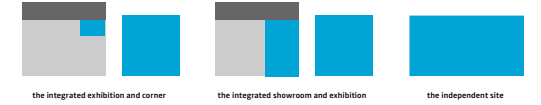

WHY?

Depending on the location configurations, the open offices of renew advisors can be located in groups of 2.

HOW?

- 1 The clear frosted walls are located on either side of the sales offices.
- 2 A dark-colored central wall separates the advisors' offices when they are assembled in groups of 2.
- 3 The rear wall, 2.10 m high, is white with renew marking in matt black adhesive.
- 4 Dark grey carpet covers the entire office area.
- 5 Alternatively, the rear wall can be black with the renew signature reversed to white.

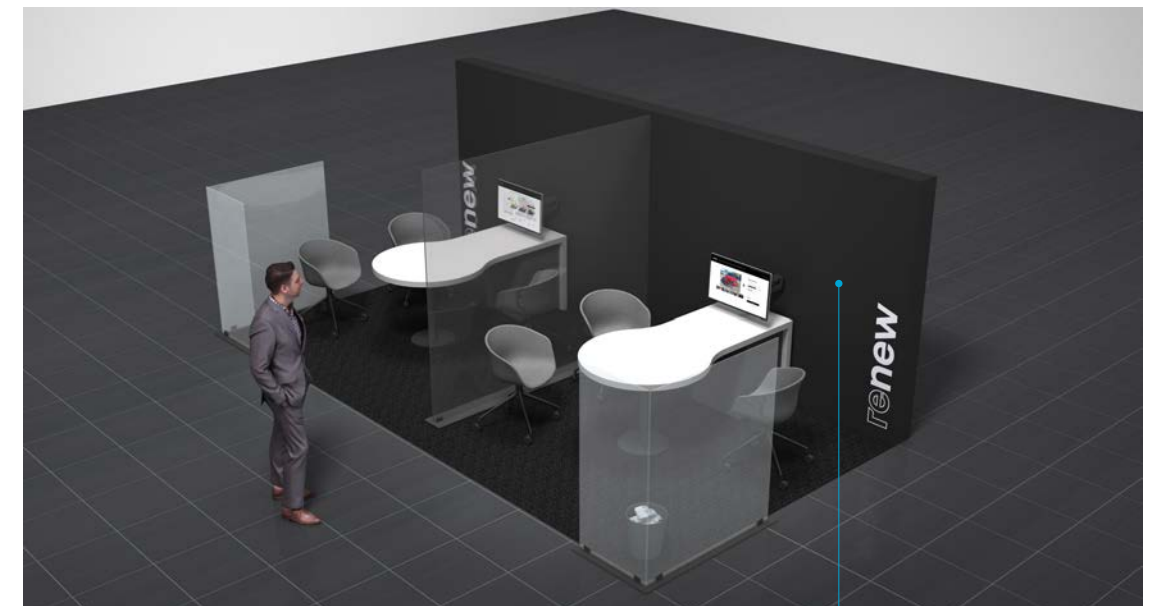

6.13 Open office configurations (2)

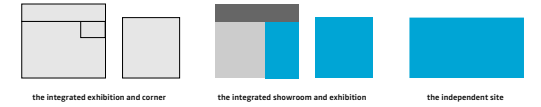

WHY?

Depending on the surface area of the renew showrooms, the open offices of the renew advisors can be set up either in single modules or in groups of 2 modules.

HOW?

- 1 When installed in a separate module, a minimum distance of 1m must be respected in order to preserve the confidentiality of exchanges in each office.

It is recommended to use large format life style visuals printed on stretched canvas (h. 3000 x L. 2700mm) in order to liven up sales areas (see recommendations in the Renault retail architectural guidelines). However, depending on the installation case, the back wall may remain white.

- 2 The open offices of renew advisors can be assembled by 2 modules comprising a straight partition with a height of 2000mm, perpendicular to the wall.



1



2

6.14 Description of open offices



WHY?

The open offices are located either in the showroom between the vehicles presented, or against the back wall of the showroom.

Two configurations exist:

- simple island module,
- assembly of 2 simple modules.

HOW?

- 1 The white work table can accommodate 2 clients.
- 2 The advisor's chair is dark grey. It differs from chairs intended for customers.
- 3 The chairs for customers are dark grey in color.
- 4 The dark grey partition (h. 1400 mm) made of PMMA is always located behind the advisor as part of the island configuration.
- 5 The partition in frosted white finish (h. 1400 mm) made of film-coated PMMA is installed in the opposite corner, behind the customers, as part of the island configuration.
- 6 A dark grey carpet covers the entire office surface.
- 7 As part of the 2-module configuration, a 2100 mm high wall (black or white) allows the furniture to be placed against it.
- 8 A screen mounted on a rotating arm allows renew offers to be presented to customers.
- 9 A 2000mm high glass partition in a dark grey finish (65% black) is installed perpendicularly to the axis of the back wall.

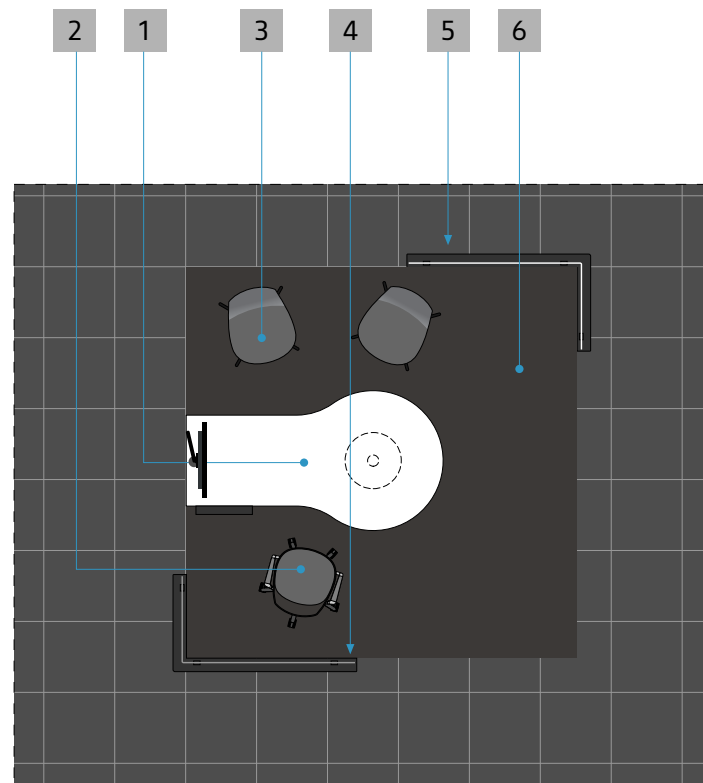

Single island module

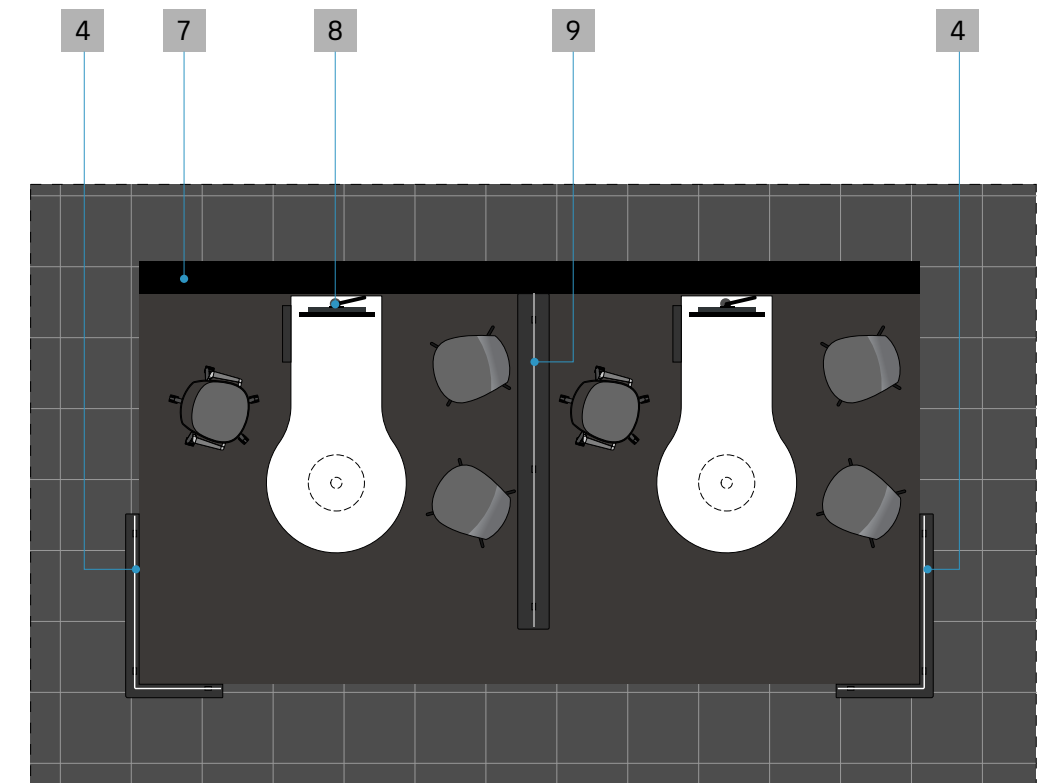

Assembly of 2 simple modules

6.15 Semi-open offices of renew advisors

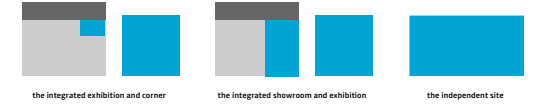

WHY?

Optionally, renew sales advisors can have a semi-open office integrated into the periphery of the new vehicles showroom.

HOW?

- 1 Glass walls create the necessary privacy in these semi-open spaces.
- 2 A dark-colored glass wall is arranged alternating with the light parts.
- 3 The back wall has a large format visual, made of stretched canvas, helping to create a warm atmosphere (see recommendations in the Renault retail architecture guidelines).
- 4 The chairs for customers and sales advisors are the same color.
- 5 In each office, a large format screen installed on a matt black wall allows renew offers to be presented to customers.
- 6 The renew signature on the white wall opposite the one with the screen identifies the renew sales area.
- 7 Dark grey carpet demarcates and provides comfort to the area.

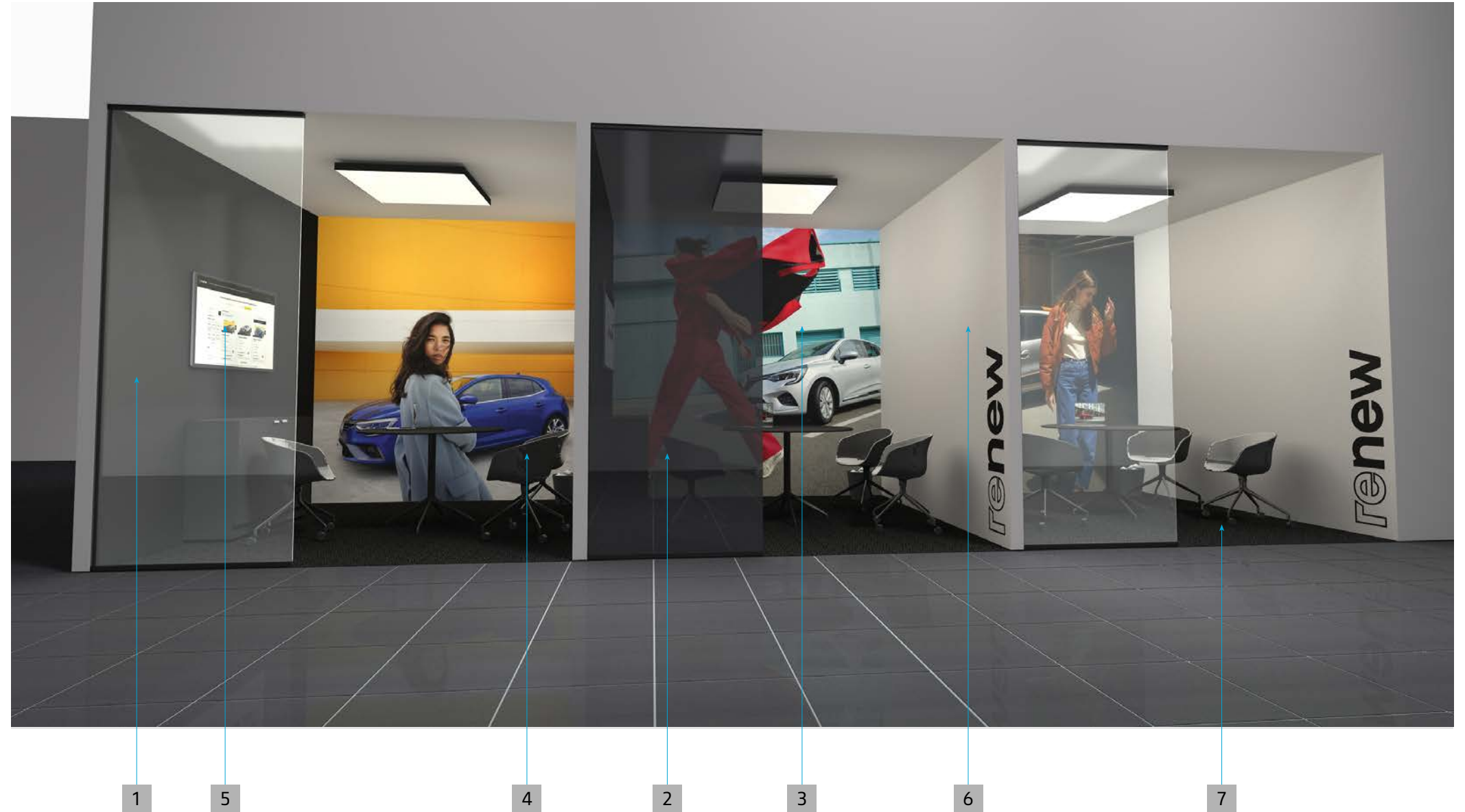

6.16 Description of semi-open offices



WHY?

Two variants are offered: a semi-open variant and an open variant, located on the outskirts of the showroom.

HOW?

- 1 The white work table can accommodate 2 clients.
- 2 The advisor's chair is dark grey. It differs from chairs intended for customers.
- 3 The chairs for customers are dark grey in color.
- 4 The full-height glass partition is made of white glass with a frosted film.
- 5 The large format screen is centered on the matte black wall opposite the frosted glass partition.
- 6 A dark grey carpet covers the entire office surface.
- 7 The door is optional allowing you to create a semi-open office.
- 8 A full-height glass partition in dark grey finish (65% black) alternates with glass partitions in frosted finish in the case of joint installation of renew offices.
- 9 The front glass partition is only covered on 1/4 to 1/3 of its width by the frosted finish film.

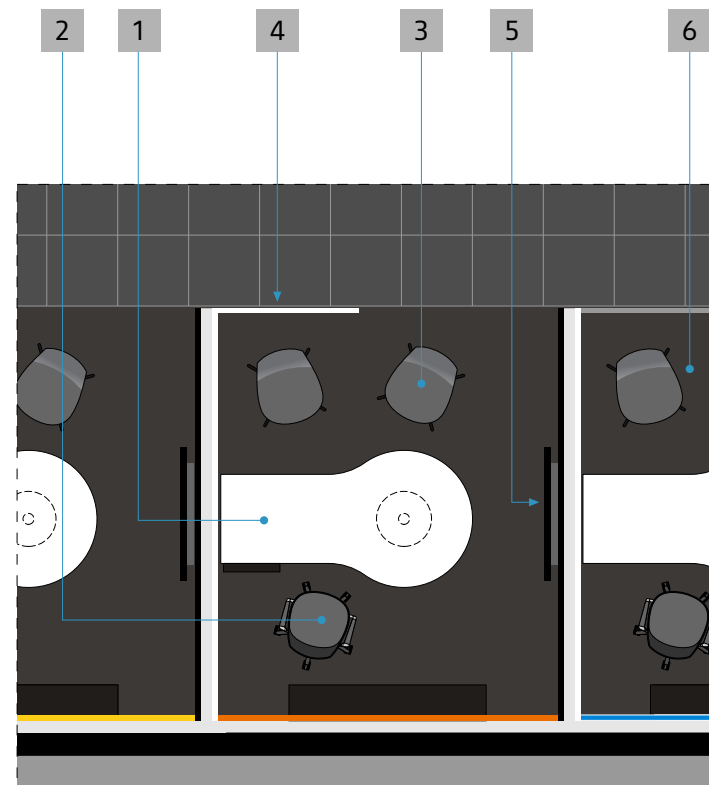

Semi-open office

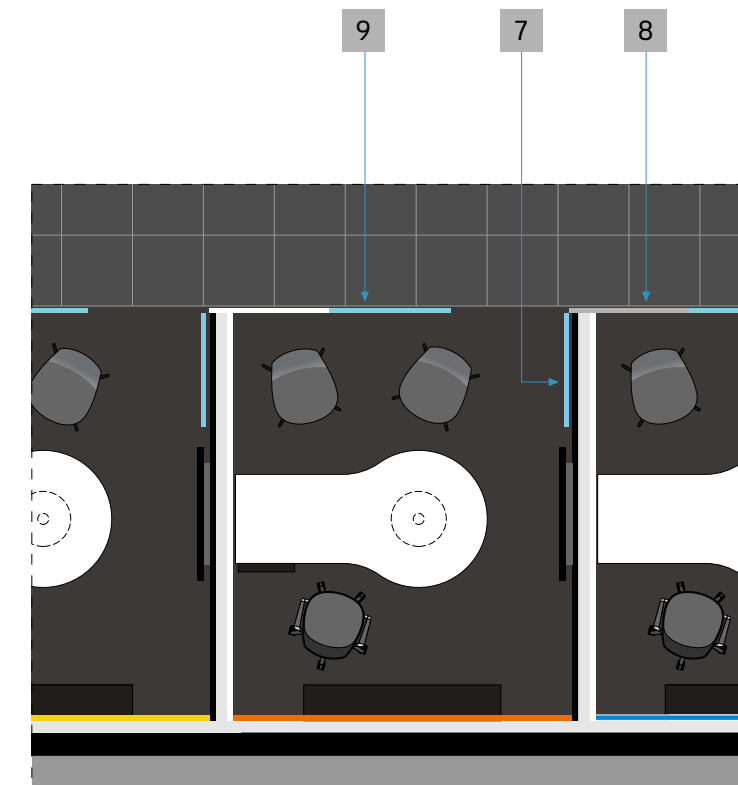

Semi-open office with door

7

THE RENEW CORNER IN A MULTI-LABEL SHOWROOM

7.1 What are we talking about ?

WHY?

Part of the showroom is dedicated to the exhibition of used renew vehicles.

The exterior exhibition is present in the majority of cases, completing the renew offer.

Note that there are no renew sales advisors present in these configurations.

HOW?

- 1 Inside the multi-label showroom, a renew corner presents vehicles labeled renew.
- 2 renew sales advisors welcome customers in dedicated offices.
- 3 In addition, the renew outdoor exhibition is located on one side of the multi-label showroom.
- 4 The renew exhibition area is identified by an area flagpole.
- 5 As an option, a sales area can also be set up in the outdoor exhibition depending on the number of vehicles present.
- 6 The renew exhibition can be located either to the right or to the left of the building housing the multi-label showroom.

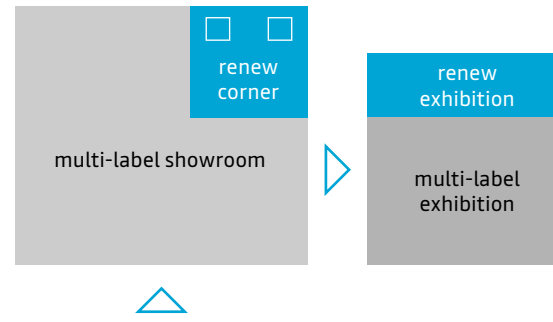

renew corner in a showroom and outdoor exhibition.
Sales offices are in the showroom.

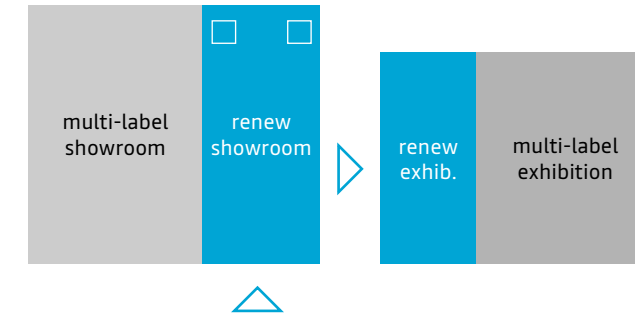

renew showroom and outdoor exhibition.
Sales offices are in the showroom.

7.2 General view of a renew corner

WHY?

The renew corner allows vehicles labeled renew to be presented in a multi-label showroom.

This configuration is suitable for the presentation of 1 to 15 vehicles.

Beyond 15 vehicles, the exhibition rules to be adopted are those defined within the framework of the renew showrooms.

HOW?

- 1 A marking on the floor demarcates the exhibition area dedicated to the presentation of renew vehicles.
- 2 The customer promise is present on a stand-alone totem. As an option and depending on the space available, a 2x2 POS can present the renew promotional offer.
- 3 A renew plate covers the license plate confirming the presence of the renew brand in the showroom.
- 4 A windshield sticker identifies the renew offer offered for each vehicle. It is affixed in the upper left corner of the windshield.
- 5 A price label is present behind the windshield of each vehicle, attached to the rear-view mirror.



7.3 lay out of a renew corner

WHY?

The layout of the vehicles must offer an organized appearance and stand out at first glance from the other vehicles present in the multi-label showroom.

HOW?

- 1 The customer promise panel is the first element that customers see in the corner renew approach.
- 2 Vehicles are parked in a row at 90° to traffic. The front of the vehicles is always focused on customer flow.
- 3 The vehicles are located in a fictitious frame of 2.5 m.
- 4 A white adhesive floor marking demarcates the renew corner.
- 5 As an option, a sales office can be set up in the corner.
- 6 The optional 2x2 POS is aligned with the customer promise panel, its visual contributing to the attractiveness of the exhibition.

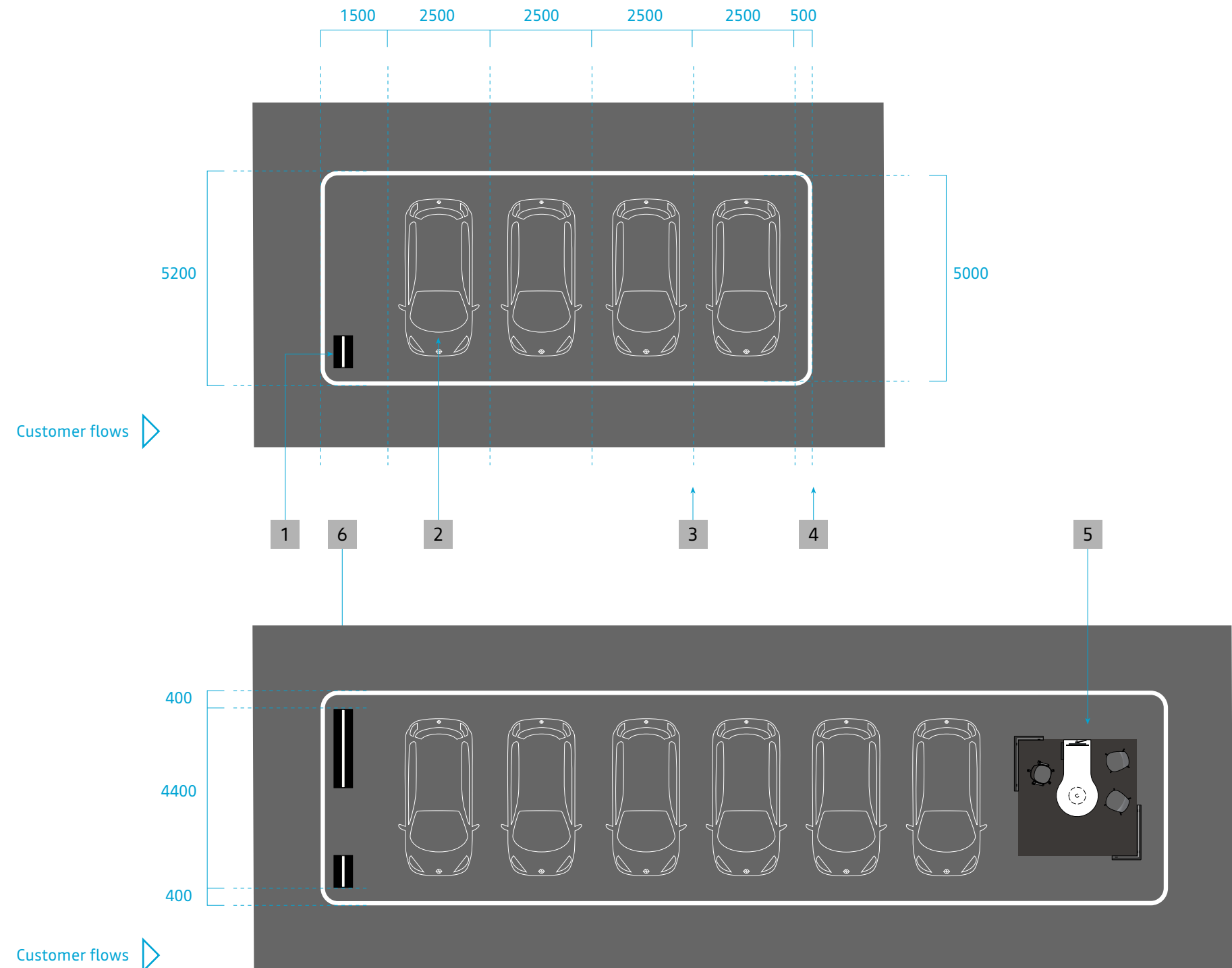

7.4 renew advisor offices

WHY?

Sales offices may be present in multi-label showrooms.

To welcome customers, the sales advisors have semi-open offices located, if necessary, near the renew corner.

HOW?

The image opposite shows a configuration combining 2 sales offices with a black wall bearing the renew signature.

- 1 In order to better demarcate the dedicated sales space and identify the presence of the renew brand, it is possible to back the sales offices against a black wall bearing the renew signature.
- 2 Side walls create the necessary privacy in these open spaces. The clear wall has the renew signature in reserve in the frosted decor.
- 3 In this 2-module configuration, the dark-colored transparent wall is located at the axis of the area separating the 2 sales offices.
- 4 The furniture combines a dark grey storage box with a white top to welcome the customer in a friendly atmosphere.
- 5 The chairs for customers and sales advisors are the same color.
- 6 A screen is integrated into the furniture presenting the renew offers to customers.
- 7 Dark grey carpet demarcates and provides comfort to the area.

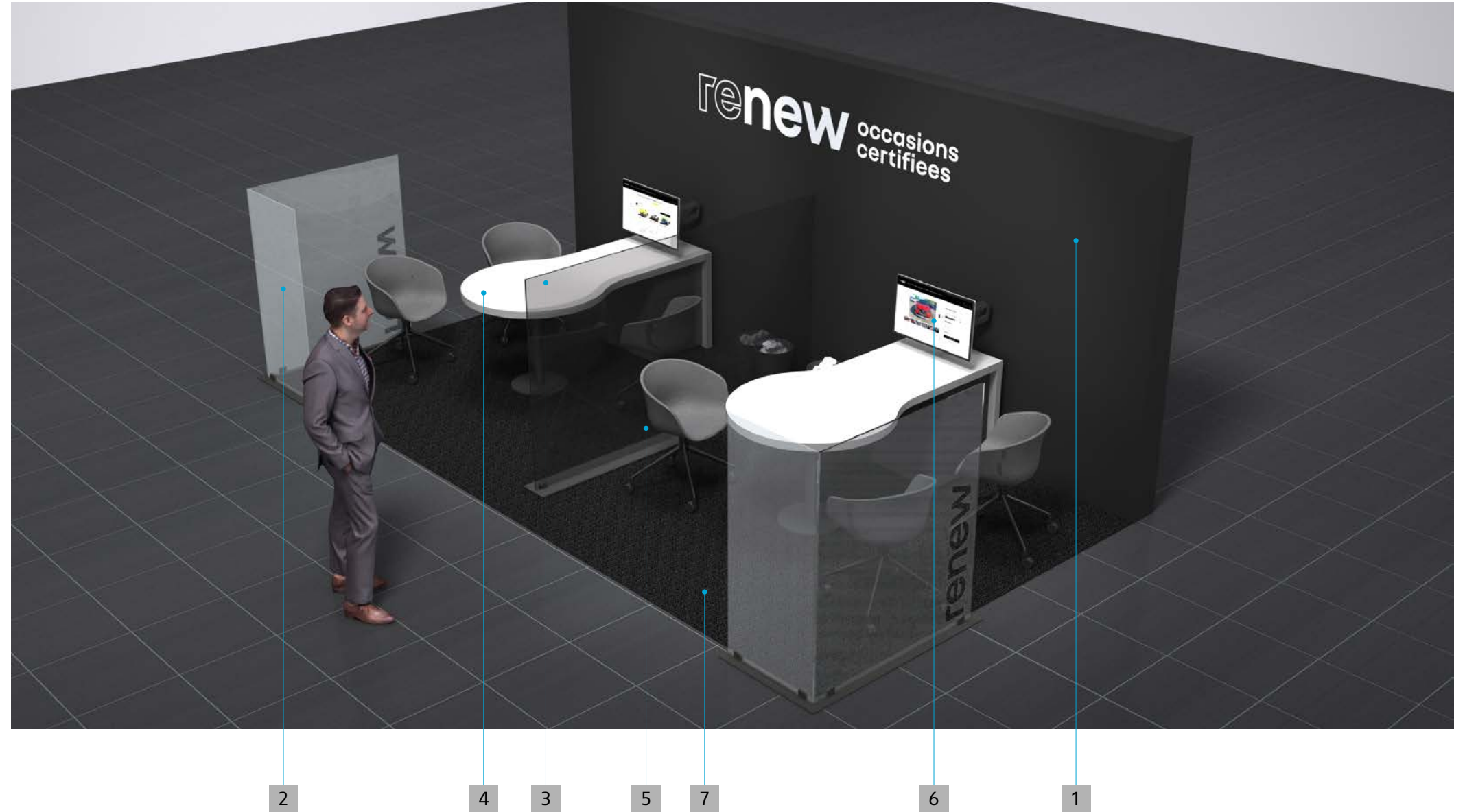

7.5 Component table

A FLEXIBLE SYSTEM

In order to provide a consistent customer experience, renew sites include mandatory components.

The optional components make it possible to personalize the offer of each site according to its needs and specificities.

WARNING

This table presents the main lines of use of the different families of components.

Please refer to the detailed description of each of the configurations which are available depending on the number of vehicles present on the site.

- mandatory
- optional
- not applicable

Components		< à 5 véhicules	de 5 à 15 véhicules	> à 15 véhicules
Identification signage	renew flags	<input type="checkbox"/>	<input type="checkbox"/>	<input type="checkbox"/>
	Arch	<input type="checkbox"/>	<input type="checkbox"/>	<input type="checkbox"/>
	Area mast	<input type="checkbox"/>	<input checked="" type="checkbox"/>	<input checked="" type="checkbox"/>
Infrastructures	Dedicated customer parking	<input type="checkbox"/>	<input type="checkbox"/>	<input type="checkbox"/>
	Independent access	<input type="checkbox"/>	<input type="checkbox"/>	<input type="checkbox"/>
Components of the outdoor exhibition	Central bay markings	<input type="checkbox"/>	<input checked="" type="checkbox"/>	<input checked="" type="checkbox"/>
	Customer promise panel	<input type="checkbox"/>	<input checked="" type="checkbox"/>	<input checked="" type="checkbox"/>
	Generic banners	<input type="checkbox"/>	<input checked="" type="checkbox"/>	<input checked="" type="checkbox"/>
	Markings of exhibition areas	<input checked="" type="checkbox"/>	<input checked="" type="checkbox"/>	<input checked="" type="checkbox"/>
	Lighting masts	<input type="checkbox"/>	<input checked="" type="checkbox"/>	<input checked="" type="checkbox"/>
	Promotional tarpaulin	<input type="checkbox"/>	<input checked="" type="checkbox"/>	<input checked="" type="checkbox"/>
	renew sales area	<input type="checkbox"/>	<input type="checkbox"/>	<input type="checkbox"/>
Showroom facade	Input marking renew	<input type="checkbox"/>	<input type="checkbox"/>	<input type="checkbox"/>
	Customer promise panel	<input type="checkbox"/>	<input type="checkbox"/>	<input type="checkbox"/>
Showroom components	renew sales offices	<input checked="" type="checkbox"/>	<input checked="" type="checkbox"/>	<input checked="" type="checkbox"/>
	Customer promise panel	<input checked="" type="checkbox"/>	<input checked="" type="checkbox"/>	<input checked="" type="checkbox"/>
	Identification box	<input checked="" type="checkbox"/>	<input checked="" type="checkbox"/>	<input checked="" type="checkbox"/>
	Area panels	<input checked="" type="checkbox"/>	<input checked="" type="checkbox"/>	<input checked="" type="checkbox"/>
	renew brand wall	<input checked="" type="checkbox"/>	<input checked="" type="checkbox"/>	<input checked="" type="checkbox"/>
	2x2 POS	<input checked="" type="checkbox"/>	<input checked="" type="checkbox"/>	<input checked="" type="checkbox"/>

You are looking for

- radio and print assets, POSM/POS content, etc.
consult the renew Toolbox produced by Renault Global marketing and the site www.act.diadeis.com/
- catalogs and technical specifications for the contents/media of the commercial network (POSM, interior and exterior signage, interior and exterior architecture)
www.brandstores.renault.com/

Note. All PDF files are vectorized: images and plans can be extracted by software mastered by agencies or suppliers (illustrator, inkscape, etc.)