

renault signage

renew areas

technical requirements

edition v1f - june 2022

1

technical requirements

general technical requirements

1.1 PREAMBLE

Renault expects all those involved in the "Renault Store" programme to meet their obligations in terms of results as per the requirements of the Technical Specifications. The general rules and specificities set out below are to be considered as the minimum necessary that has to be done to achieve the expected result.

1.2 SAFETY OF PERSONS AND PROPERTY

The supplier shall be able to provide proof that it has analysed the risks related to the services it is to provide and that its personnel and any sub-contractors have undergone sufficient training. Strict compliance with legislation in terms of safety and protection of workers is required.

1.3 RESPECT FOR THE ENVIRONMENT

Materials and methods which make it possible to reduce harm to the environment shall be used wherever possible (recyclable materials, energy-saving technologies, toxicity of materials and products used, etc.).

The supplier shall be able to provide proof that it has the various administrative permits (operating permit, environmental permit) necessary to manufacture the various items of equipment and that it complies with the operating conditions required by the legislation in force or by the specific operating conditions in the countries concerned.

A global approach such as the ISO 14001 standard is recommended.

1.4 QUALITY

The supplier shall be able to provide proof that it works in accordance with ISO 9000 quality assurance standards, formal certification being particularly recommended in this regard. The signmaker shall attach a specific Quality Plan to its offer to assure Renault of its capacity to supply finished products and spare parts that are compliant with the contractual requirements, within the set time periods. It shall request its sub-contractors to do likewise.

The procedures applied must make it possible to:

- Be sure that the parts and products purchased, manufactured and supplied shall neither be used nor delivered before they have been checked and be recognized as compliant.
- Procedures shall be set out for identifying causes of non-compliance, which make it possible to provide sustainable solutions that can be applied more widely to resolve the non-compliance and prevent it reoccurring.

These operations shall be recorded in the appropriate documents and be approved by Renault prior to being applied more widely.

- Track changes in the quality of products and assembly and removal services using inspection and audit indicators (incidents, complaints, etc.).

This tracking shall result in preventive or corrective actions; they shall be approved by Renault before being applied.

1.5 COMPLIANCE OF MESSAGES AND COLOURS

Visuals must comply with the official images contained in this document.

All shades have a 40% satin finish unless specified otherwise. Particular attention should be paid to complying with the colour code.

Compliance with the tolerances for the L.a.b. is required.

general technical requirements

2.1.1 STANDARDS

The reference base to be followed for design and manufacturing shall, at the very least, be that required by Eurocode standards.

The regulations relating to the dimensioning of structures in force in each of the countries concerned shall be complied with taking climatic conditions into account.

The following obligations in terms of results must be met:

- Supported under their own weight, the equipment must appear perfectly horizontal and vertical.
- The parallel alignment of separate elements must be observed.
- Under normal wind conditions (Cf. NV65 and NF EN1991-1-4 (Eurocode 1)), the permissible bend between the fastening and the point most distant from the fastening (dimension "d") shall not exceed $d/100$.

2.1.2 CLIMATIC CONDITIONS

Wind loads to be considered for the design of structures shall be taken from the Eurocode 1 rules (EN 1991-1-3): zones 4 (28 m/s), roughness IIIb, force coefficient equal to 1.80. Any structure situated in an unfavorable geographical area with regard to this load case shall be subject to a special design basis in order to meet the applicable standards.

2.1.3 DESIGN RULES

2.1.3.1 ALUMINIUM STRUCTURES

Design rules for aluminium structures - most recent edition of DTU rules (currently, July 1976).

Applicable standard for the execution of structures: NF EN 1090-2 and Eurocode 9.

2.1.3.2 STEEL STRUCTURES

Design rules for steel structures CM 66 » - most recent edition.

Applicable standard for the execution of structures: EN 1093 and Eurocode 3.

2.1.3.3 CONCRETE BLOCKS

Concrete blocks shall be of "weight" type with minimum reinforcement.

The concrete to be used shall have an ordinary Portland cement (OPC) content of 400 kg/m³ (s'28=300 bars - s28=25 bars).

2.1.3.4 DESIGN CALCULATIONS FOR PLASTIC ELEMENTS

Adapt the CM 66 rules using a safety coefficient of 2 for the stresses.

2.1.4 MATERIALS

2.1.4.1 GENERAL REMARKS

The materials used shall all be first-choice materials suitable for their envisaged use and they shall be used in accordance with the rules of best industry practice for the profession and in compliance with the standards and regulations in force in France and in the Countries in which they are intended to be used.

The materials used shall not have any defect that is likely to compromise the durability of the structures. The equipment shall be easy to clean, maintain and service.

The materials shall be capable of withstanding harsh climatic conditions such as rain, snow, hail, condensation, dust and salt spray.

Operation must be guaranteed between - 20 and + 80 ° C.

general technical requirements

2.1.4.2 STEELS

Steels shall be either "hot finished" as per NF EN 10210 or "cold finished" as per NF EN 10219-1 and 2. The quality of the steels shall be stated on the production drawings and it goes without saying that the mechanical properties of the different types of steels must be taken into account for stability calculations.

All elements shall be manufactured in a covered, sheltered location.

After machining, welding, drilling, notching, etc. the elements shall be prepared prior to anti-corrosion treatment: brushing of welds, careful deburring, cleaning, shot peening and sand blasting.

The anti-corrosion treatment shall be performed by hot galvanization of a minimum of 80 µm and shall provide fault-free protection for at least the period of the ten-year guarantee.

No machining may be carried out once the parts have undergone anti-corrosion treatment.

All fasteners and hardware (including hinges) shall be made of 18/10 stainless steel (NFE 25.033).

2.1.4.3 ALUMINIUM

The reference standard is NF EN 573-1. Parts used in a supporting structure shall be chosen from the "6000" series. For parts which are not used in a supporting structure, the "1000" series shall be acceptable.

The alloys are to be weldable.

The parts shall be carefully deburred and the welds shall be brushed before any protective treatment.

The visible parts of equipment shall be treated by the application of paintwork performed according to a "Qualicoat"-type procedure.

2.1.4.4 PMMA

The PMMA shall meet at least the following characteristics:

	Flat parts machined "cast" PMMA	Flat parts unmachined "extruded" PMMA
· Opal white (values for a test piece of 3mm thick)		
· Tensile strength	> 75 MPa	> 70 MPa
· Bending strength	> 130 MPa	> 120 MPa
· Bending modulus	> 3,250 MPa	> 3,000 MPa
· Unnotched CHARPY impact test strength	> 12 MPa	>10 MPa
· Expansion	<1 mm/1 m/10°C	<1 mm/1 m/10°C
· Light transmittance	> 50 %	>33 %

The thermoformed panels shall be made of white, light diffusing, extruded PMMA in compliance with the sheet manufacturer's heating parameters.

Where parts made of PMMA are more than 100 cm high, they shall be hung from the top by an adhesive PMMA cleat.

The thickness of the sheets shall be calculated in compliance with the tensile strength standards set out above.

2.1.4.5 POLYCARBONATE

The polycarbonate sheet shall meet at least the following characteristics:

- Uncoloured appearance
- Density > 1.2 g/cm³

general technical requirements

- Tensile strength: 60 Mpa
- Expansion < 0.7 mm/1 m/10°C
- Light transmittance > 90%

2.1.4.6 EXPANDED FOAM

These following characteristics must be met:

- Material 9010 white PVC
- Density > 50 g/cm³
- UV-stabilized: 14 MPa
- Shore hardness D > 75
- Expansion < 1 mm/1 m/10°C

2.1.4.7 PAINT

Painted parts must have an even appearance across their entire surface.

Defects such as pores, fissures, grains of dust, runs or waves of paint shall not be tolerated.

Samples of painted rough parts shall be tested and accepted by Renault, after having undergone the following tests performed by a certified body:

- Colour based on a LAB test with a MINOLTA 508 D colorimeter with D65 illuminant and the observer at 10° and specular component included (the tolerances in the CIELAB colour space are L +/- 1, a +/- 1.5, b +/- 1.5).
- Gloss at 40 °: based on a test according to NF T 30064 standard.
- Gloss at 60 °: based on a test according to NF T 30064 standard
- Adhesion: resistance to peeling based on grid test.

Class 1, as per P UW150 1. NF T 30038 standard

- Colour fastness:
QUV as per NF T 30036 after 200 hours of exposure.

Samples of each of the elements shall be supplied, upon request, to Renault for inspection.

2.1.5 ELECTRICAL EQUIPMENT

Assemblies with electrical equipment shall comply with the essential safety requirements of the European Union. Within this framework, the supplier shall obtain a certificate (for each type of equipment) which must clearly state the compliance of the assemblies, and thus of the components, with:

- requirements relating to the safety and protection of users and all other persons (directive 73/23/EEC without any lower voltage threshold)
- requirements relating to electromagnetic compatibility (directive 89/336/EEC).

The rating plate on each item of equipment shall display the CE mark indicating compliance with these requirements.

The regulations relating to low-voltage signage in force in each of the countries concerned shall be complied with taking climatic conditions into account.

In addition, the following requirements shall be met:

Electrical equipment shall be compliant with the standards in force from the series NFC 15-100, NFC 20-010 and NFC 20-030, NFC 71, NFC 32 for France and the IEC 60364 international standard.

general technical requirements

This concerns the following in particular:

- Category one electrical installations and low-voltage illuminated signage installations.
- The fire behaviour of electrical equipment and the degree of protection of enclosures,
- Flexible and rigid low-voltage cables.

In addition, the equipment shall comply regulations relating to the suppression of interference in inhabited areas and shall thus be delivered with interference suppression.

2.1.5.1 IP RATING

All the electrical equipment shall have a protection rating of at least IP 44-D.

2.1.5.2 PROTECTION AGAINST ELECTRIC SHOCK

All equipment shall be "class 1".

2.1.5.3 FASTENERS

The converters shall be placed in areas not subject to standing water.

The cables and sheaths shall be fastened to structures at 50 cm intervals.

2.1.5.4 CABLE ROUTING

Every cable or sheath passing through a metal part shall be routed through a cable gland.

Connection boxes.

An IP 44 sealed plastic connection box shall be provided at the inlet to each assembly. This box shall be equipped with a 5-input connection pin for 4 mm wiring.

All the connection boxes shall have the markings P1+P2+P3+T+N.

2.1.5.5 LEDs

The white LEDs used shall have the following characteristics:

- Lifetime: 50,000 hours for a loss of initial luminous flux of 50 % at the end of the period
- 5 year guarantee for operation 10 hours per day with a maximum loss of luminous flux of 20 %
- Operating temperature of LEDs: between - 20° C and +50 °C.
- Minimum protection index: IP 67
- The LEDs used must comply with the following international standards: IEC 62504 TS Ed. 1, IEC 61231, IEC 62560 Ed 1, IEC 62031 LED module safety, IEC 61347-2-13 LED control gear.

2.1.5.6 CONVERTERS

The power supply converters for the LEDs shall have the following characteristics:

- Wide power supply voltage range (100 to 300 volts)
- Reversible protection against increase in temperature and overload
- Protection against short-circuits with automatic restart
- Minimum protection index: IP 67
- Operation compliant with: EN 55015, EN 61000-3-2, EN 61547, EN 61558-2-17.

general technical requirements

2.1.6 FASTENERS AND HARDWARE

All fasteners and hardware used shall be made of stainless steel (non-magnetizable).

Aluminium "pop" rivets are accepted as long as the steel rods are systematically removed.

For welding, the wires and electrodes are to be compliant with NF 81.830.

2.1.7 ANCHORING SYSTEMS AND FASTENINGS

The plinths for all equipments shall be completely removable without having to remove another element of the assembly. The plinths shall cover the attachment plates or fastenings. The attachment plates shall be easily accessible once the plinths have been removed.

For each of the assemblies which require a foundation block or fastening to a separate structure, the signmaker shall provide the elements necessary, as well as the conditions to be used to make design calculations for these elements (wind conditions and design calculation methods).

2.1.8 IDENTIFICATION PLATE

Each finished product shall be marked with a metal identification plate on the structure which shall show at least the following information:

- Name of the signmaker
- Product code and batch
- Month and year of manufacturing
- The CE Marking if it is illuminated.

2.1.9 STORAGE

The finished products shall be stored in a dry and well-ventilated location.

Renault inspectors shall be able to have access to them at any time.

general technical requirements

2.2. GUARANTEES

The suppliers undertake to offer the guarantee conditions below for their products:

- 2 year guarantee on the installation against defects and faulty workmanship,
- 5 year guarantee on the electrical equipment including the LEDs and converters,
- 5 year guarantee on the adhesive elements,
- 5 year guarantee on digital printing (anti UV treatment),
- 5 year guarantee on workshop-lacquered sheet metal,
- 5 year guarantee on the chrome-plated diamonds,
- 7 year guarantee on sheet metal and profiles pre-lacquered by the aluminium manufacturer,
- 10 year guarantee on the internal structures,
- 10 year guarantee on the PMMA acrylic panels.

2

general remarks

2.1 the exterior display area



description

To ensure the visibility of commercial sites, a range of flags has been developed.

These flags are intended to structure the outdoor space and improve the visibility of dealerships.

2.2 colours & materials



RAL 9010 satin white

- pre-lacquered aluminium sheeting, 15/10 mm thick
- satin finish with 40% gloss



dark grey equivalent to RAL 7021

- pre-lacquered aluminium sheeting, 15/10 mm thick
- satin finish with 40% gloss

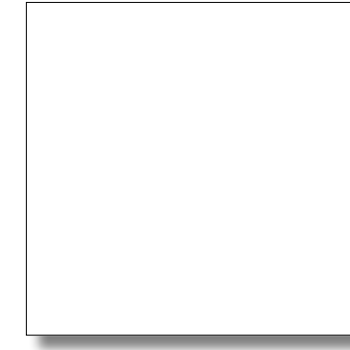

pure white

- light diffusing pmma with 40% transmittance, th. 3 mm altuglass ref. 100-27000
- matt adhesive film



black ink

- printing on polyester fabric 130 g/m²

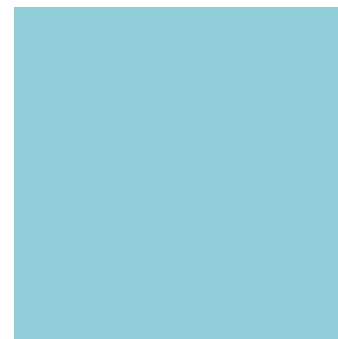

blue pantone 636 c

- printing on polyester fabric 130 g/m²

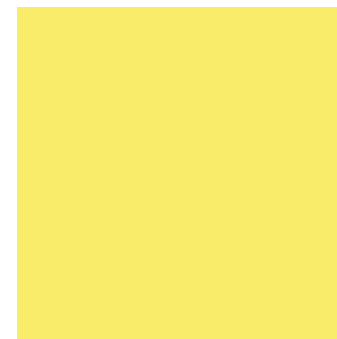

yellow pantone 3955 c

- printing on polyester fabric 130 g/m²

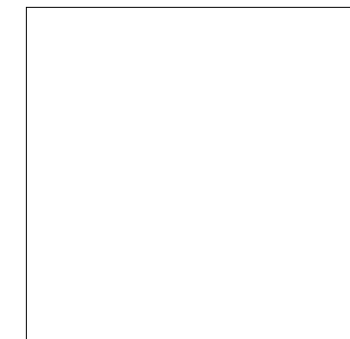

white polyester fabric

- polyester fabric 130 g/m²

3

renew signatures

3.1 international signature

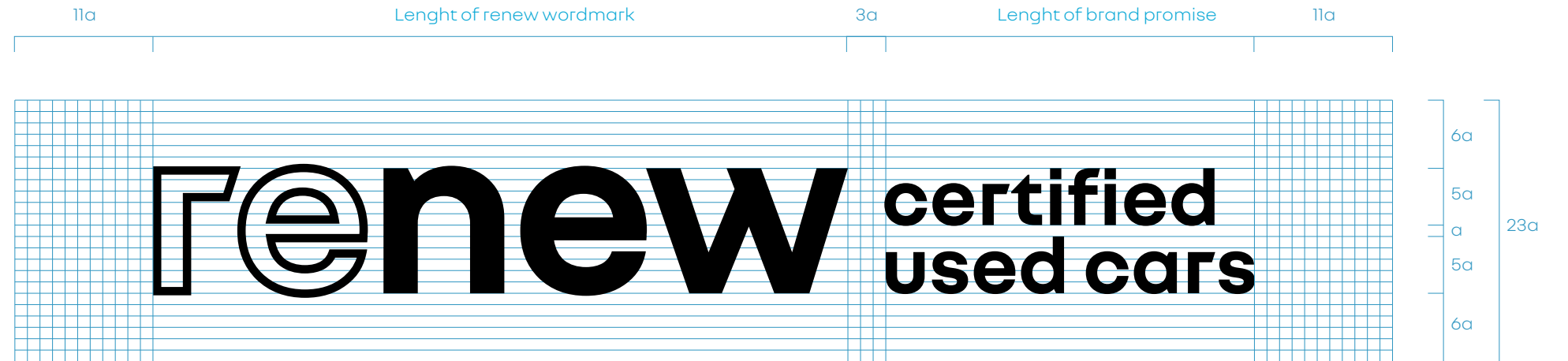

description

The complete signature shall be used on all items.

- 1 renew wordmark
- 2 renew promise
Left aligned, on two lines,
lowcases, nouvel'R Bold

3.2 signature for french network

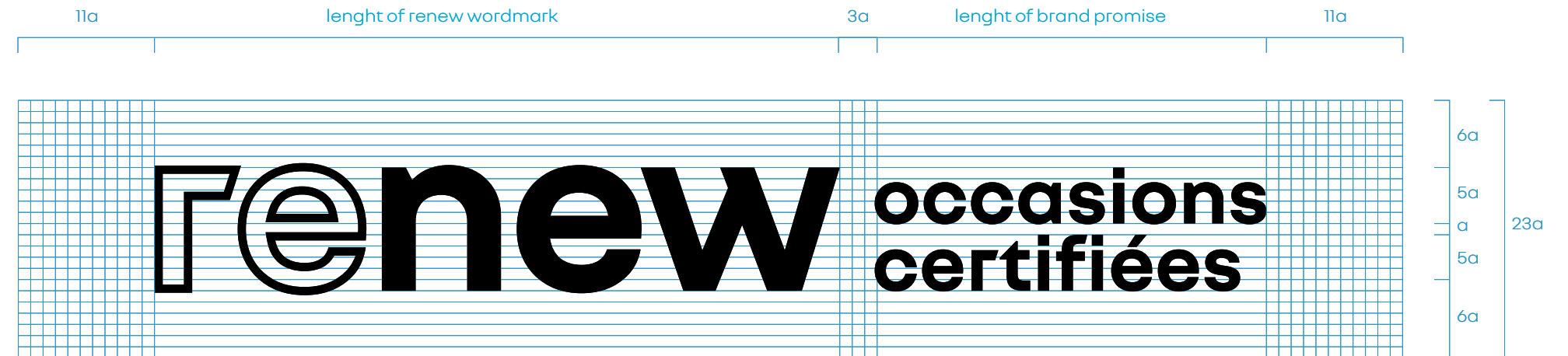

description

Construction is the same for foreign languages when needed.

- 1 renew wordmark
- 2 renew promise
Left aligned, on two lines,
lowcases, nouvel'R Bold

3.3 renew wordmark

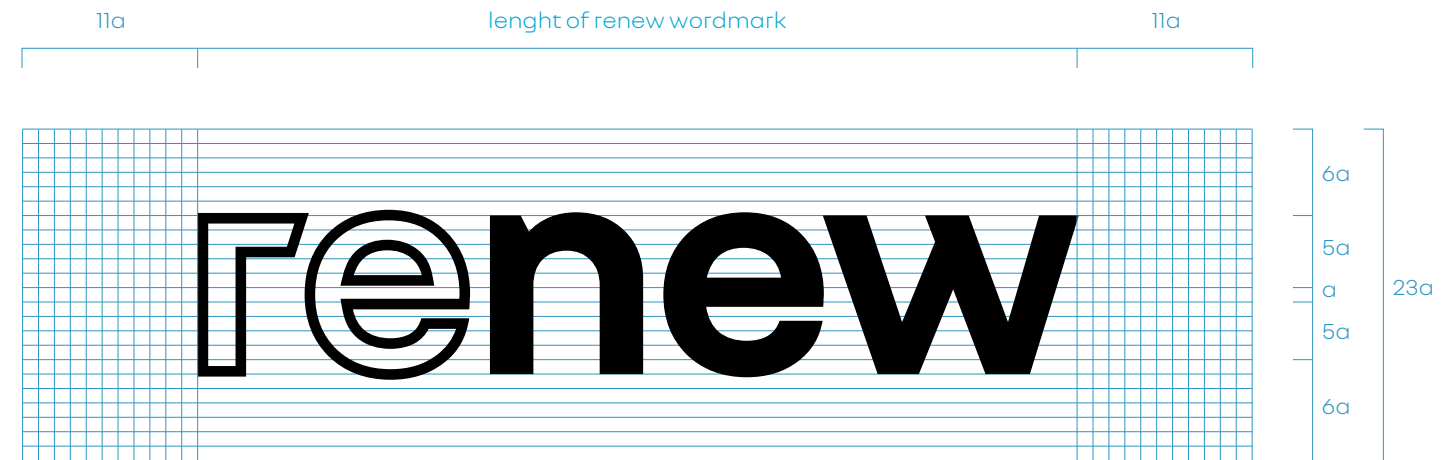

description

The renew wordmark should only be used in special case when the visibility of the renew wordmark associated with the promise is too low.

- 1 background
- 2 renew wordmark

4

**technical principles
for exterior display area**

4.1 components

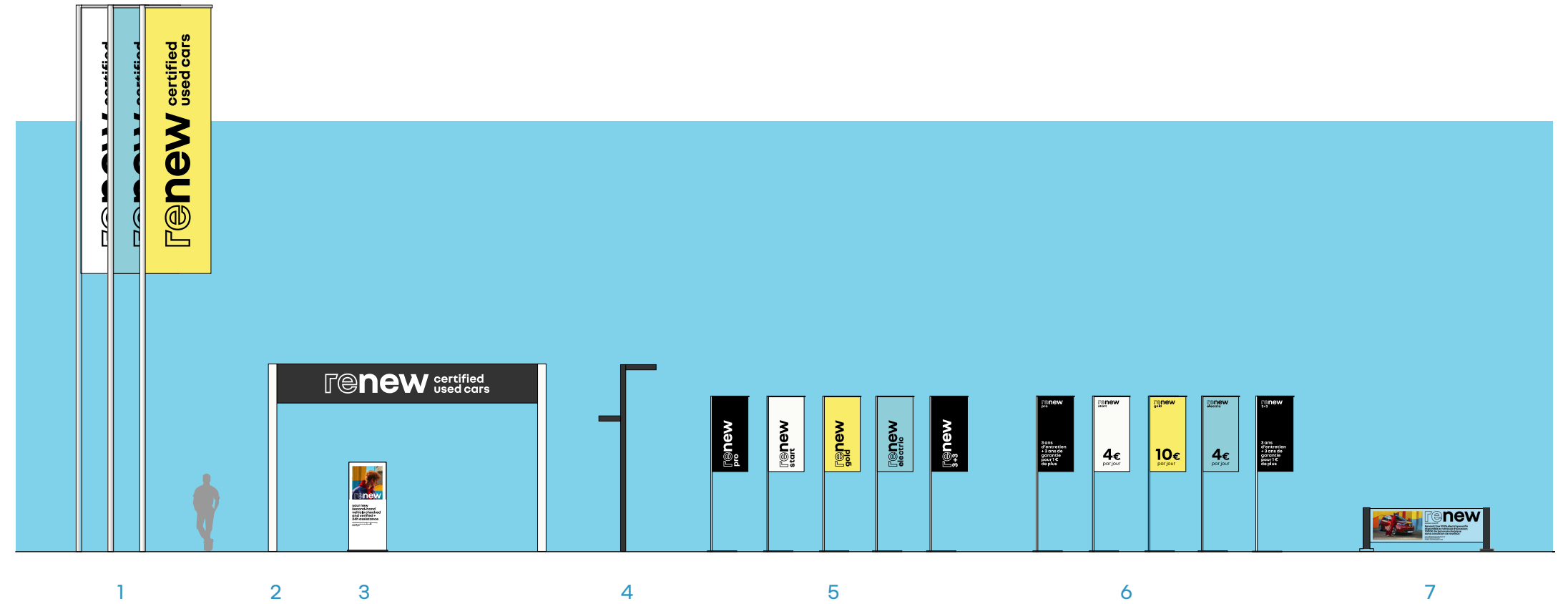

key

- 1 Flags
- 2 Arch
- 3 Promotional sign
- 4 Lighting masts
- 5 Generic standards
- 6 Promotional standards
- 7 Promotional banner

4.2 typical installation of components

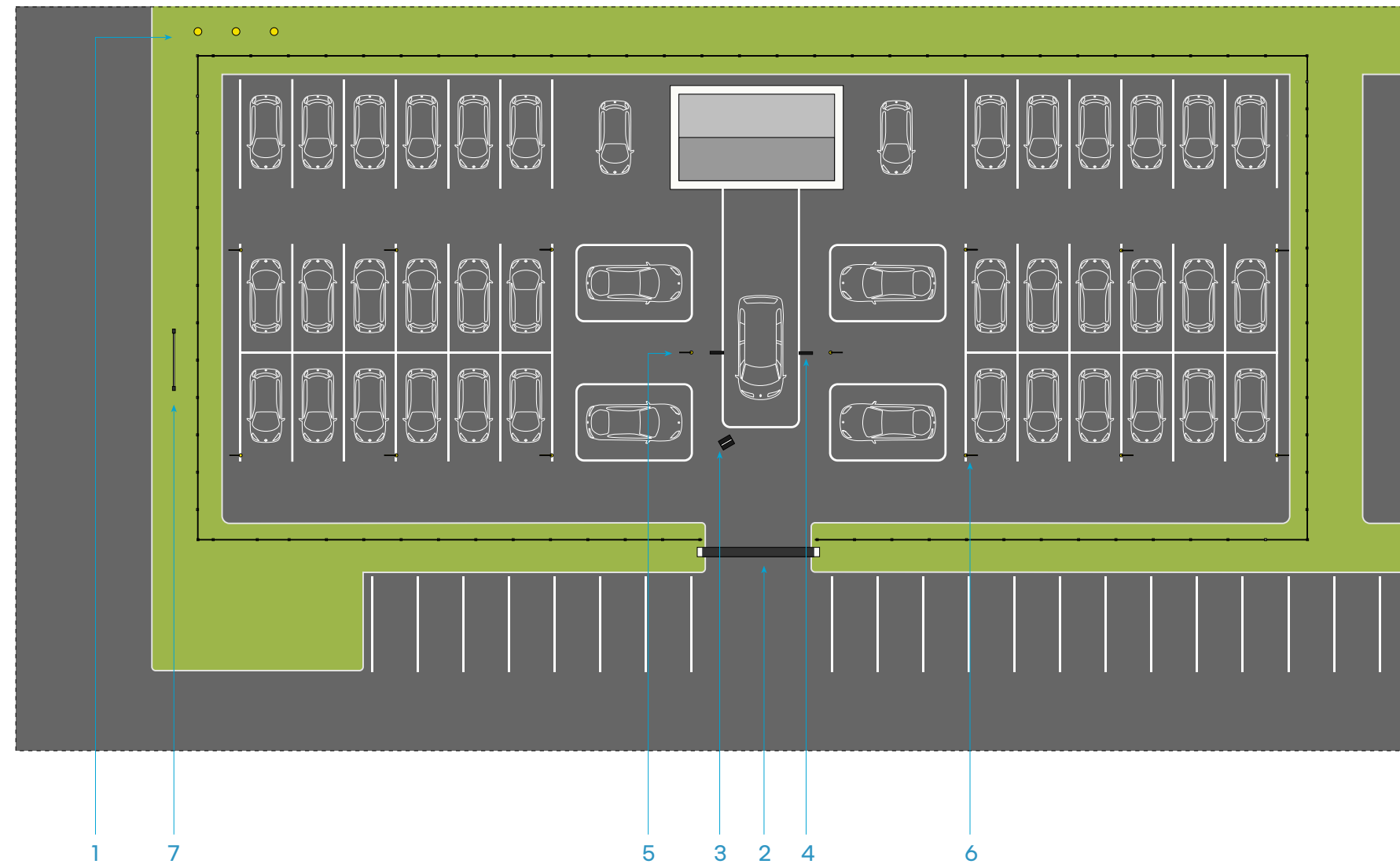

key

- 1 Flags
- 2 Arch
- 3 Promotional sign
- 4 Lighting masts
- 5 Generic standards
- 6 Promotional standards
- 7 Promotional banner

4.3 renew flags

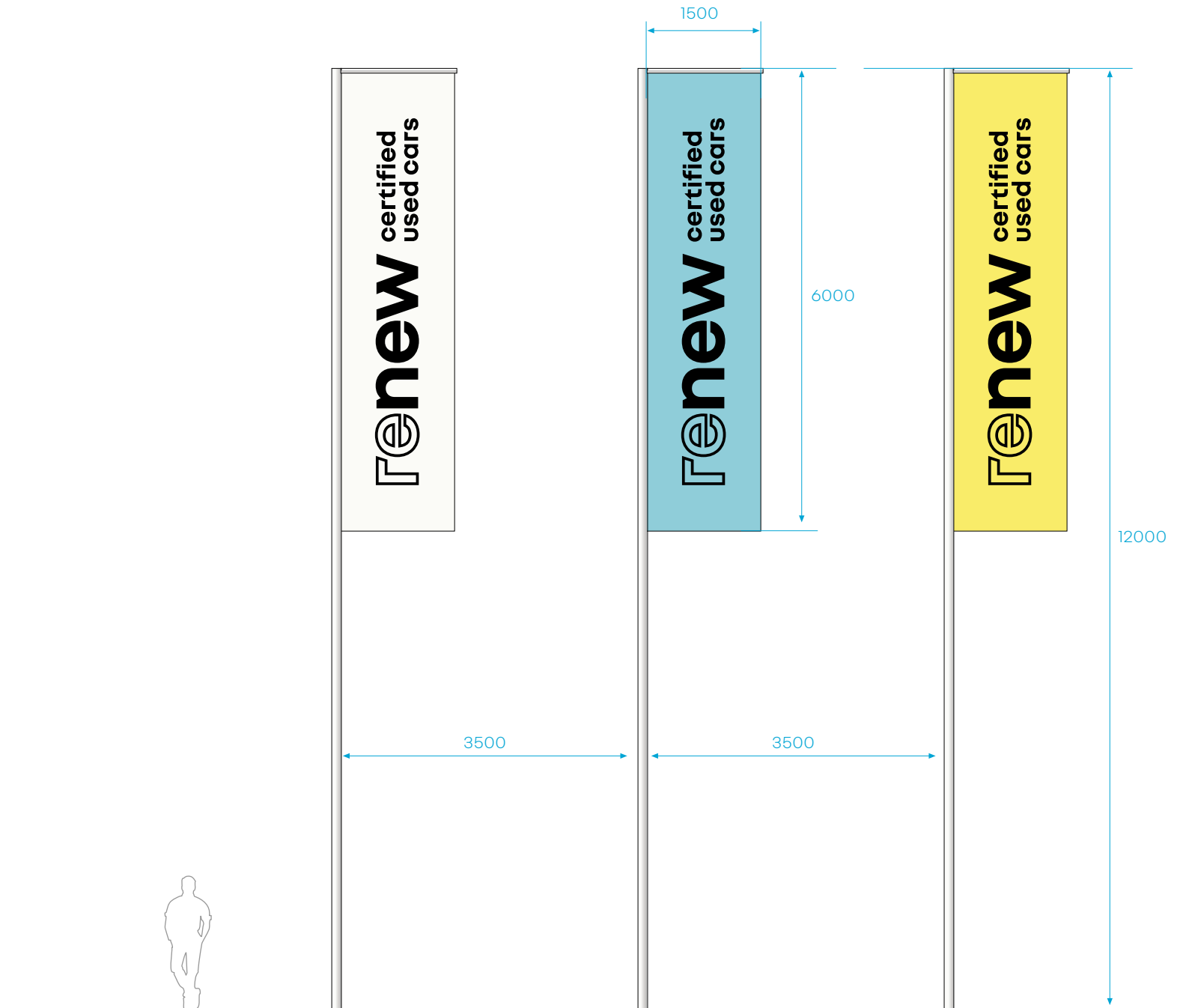

key

- 1 Flag with white background
- 2 Flag with blue background
- 3 Flag with yellow background

4.4 outline of renew flags - international version

description

The flags are printed on 130 g/m² white polyester fabric.

A vector file (.eps) is available to ensure consistent reproduction.

Special attention shall be paid to:

- the regularity of the solid colours,
- colour conformity.

key

- 1 Polyester fabric (may be printed in blue or yellow colours)
- 2 Printed signature in black

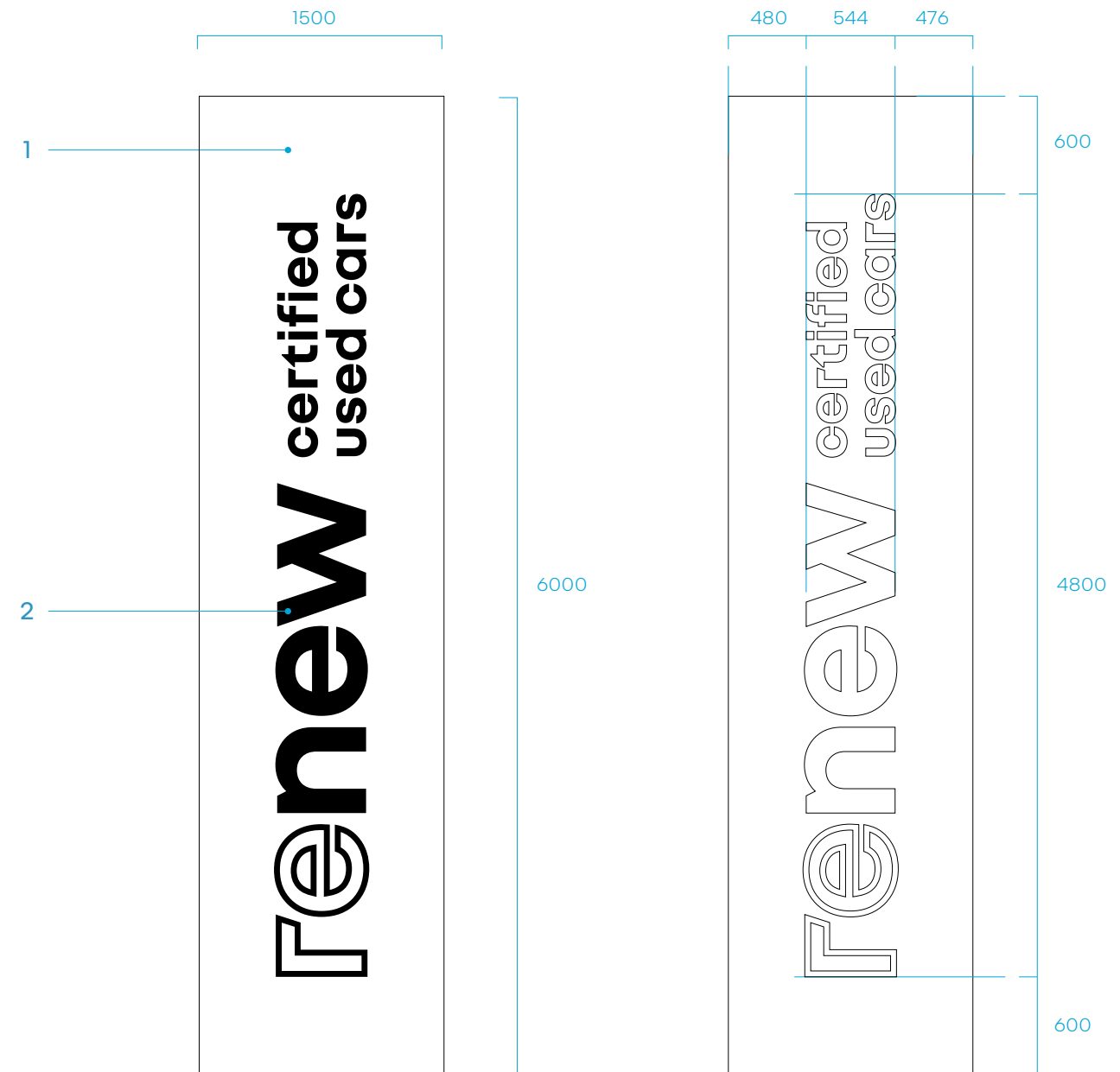

4.5 outline of renew flags - french network version

description

The flags are printed on 130 g/m² white polyester fabric.

A vector file (.eps) is available to ensure consistent reproduction.

Special attention shall be paid to:

- the regularity of the solid colours,
- colour conformity.

key

- 1 Polyester fabric (may be printed in blue or yellow colours)
- 2 Printed signature in black

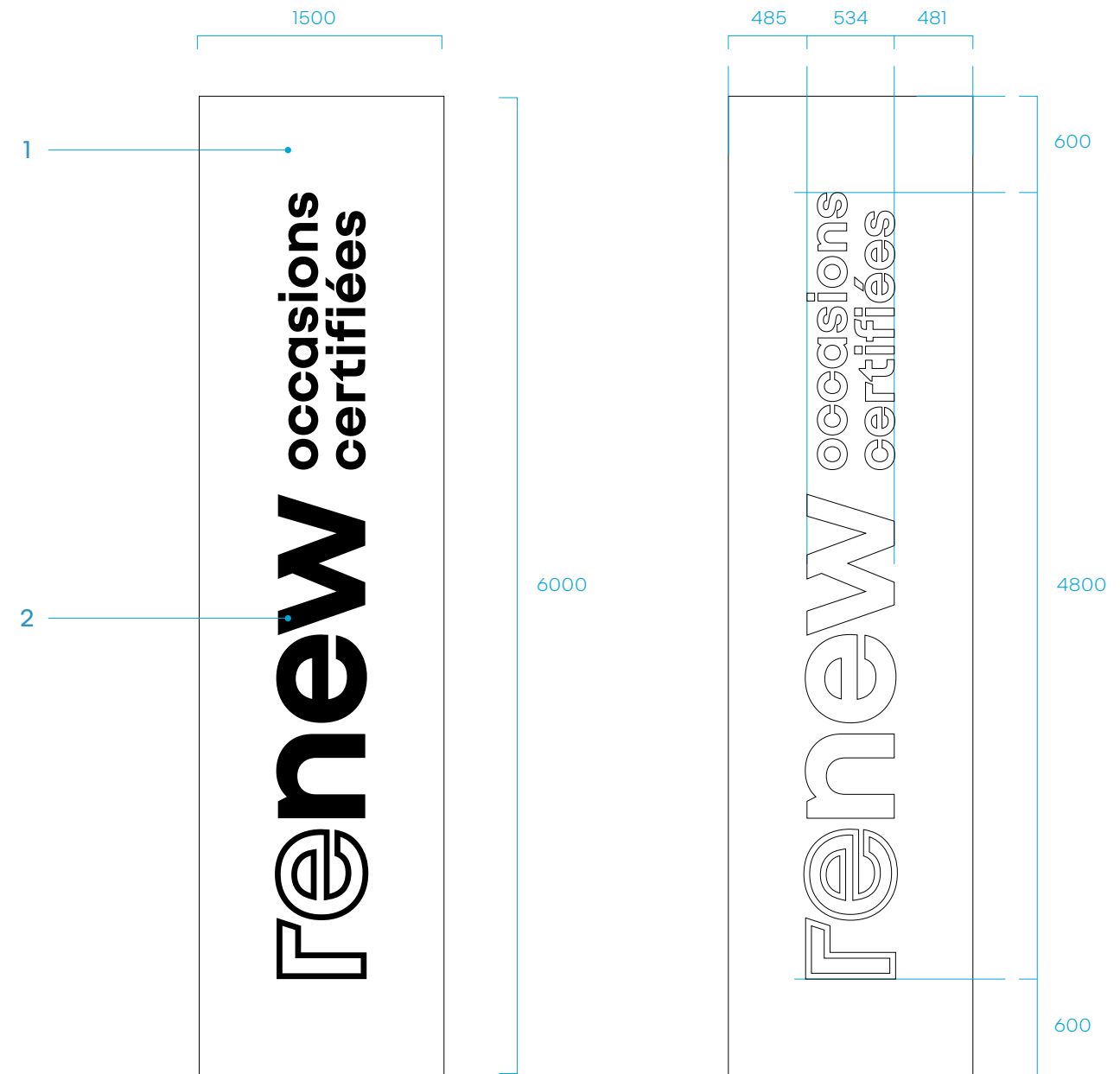

4.6 signage arch

principle

The arch identifies renew exterior displays. Located at the entry to the renew display area, it is positioned in the axis of the central bay.

- 1 Cladding of the edge of the posts in RAL 9010 white aluminium sheeting with 40% gloss
- 2 Cladding of the structure in pre-lacquered RAL 9010 white aluminium sheeting with 40% gloss
- 3 Front panel in pre-lacquered RAL 7021 dark grey aluminium sheeting with 40% gloss
- 4 Lettering in light-diffusing white PMMA integration in marquetry flush to the surface

NOTE:

The previous generations of arches can be retrofitted allowing the internal structure to be retained once the cladding sheets have been removed.

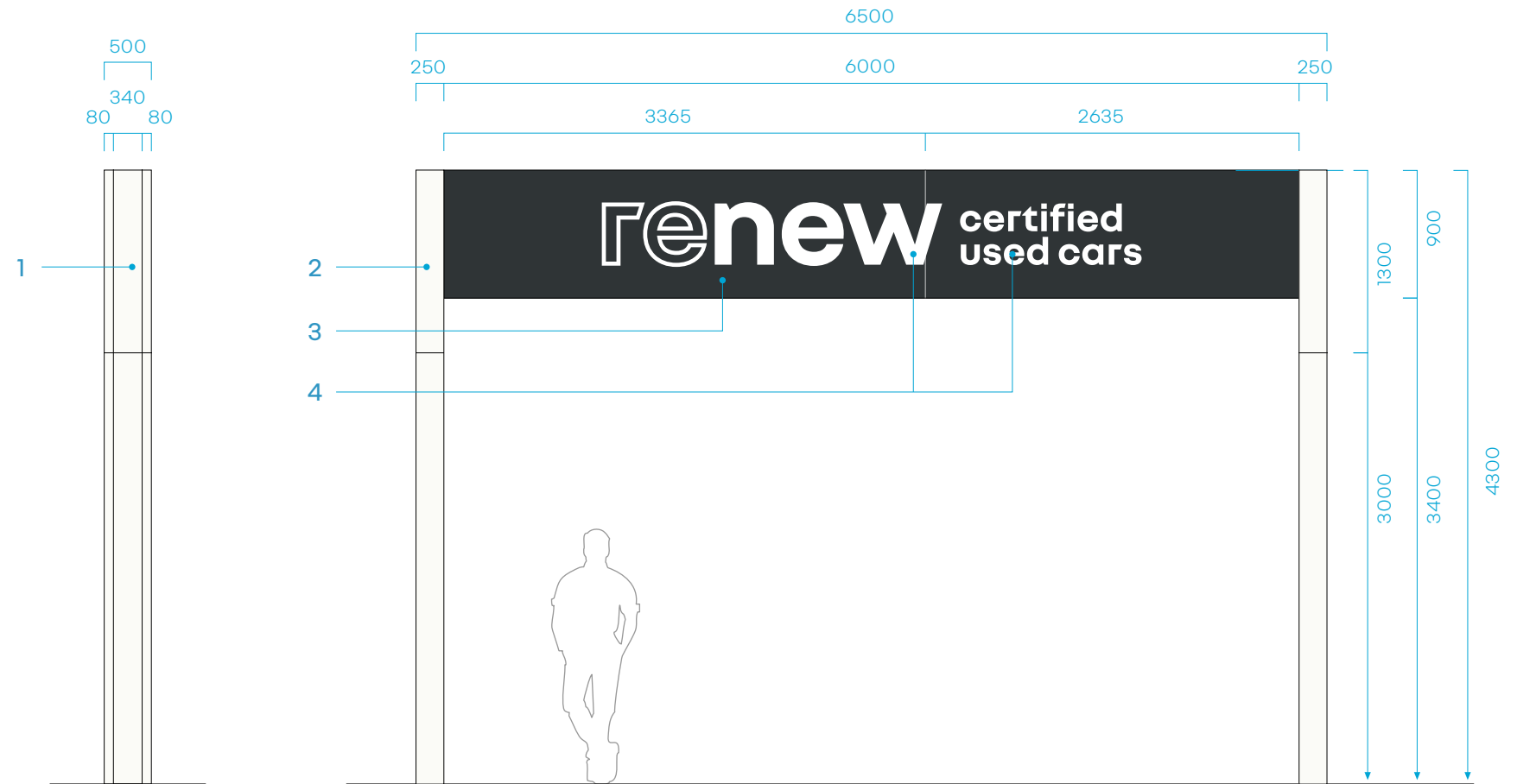

4.7 drawings of front panel of arch - international version

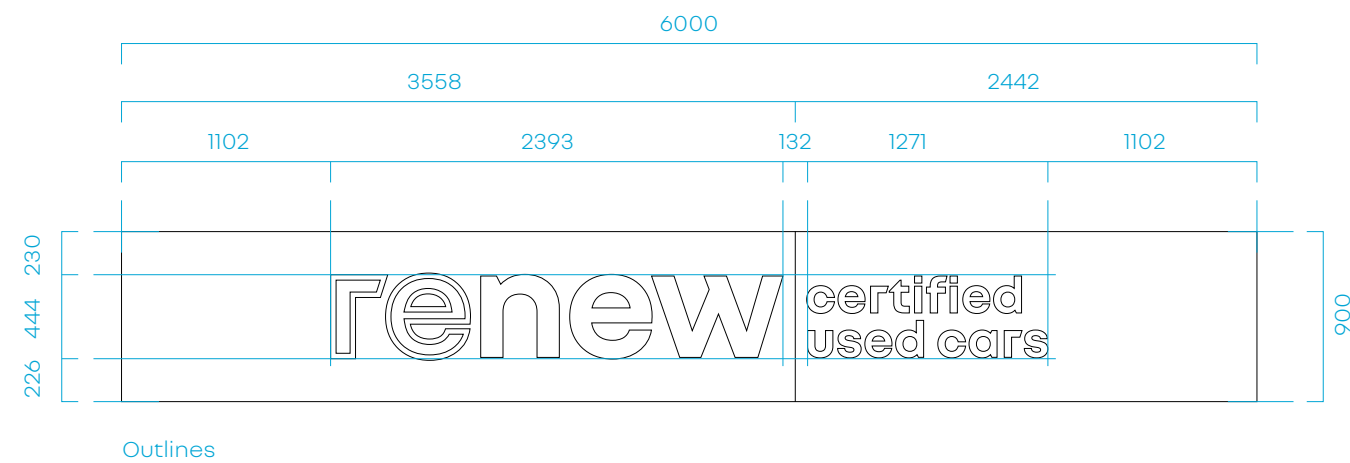

key

- 1 Complete signature in white PMMA, integration in marquetry flush to the surface
- 2 Front face divided in 2 parts, aluminium sheeting, RAL 7021 dark grey satin finish
- 3 Back face divided in 2 parts, aluminium sheeting, RAL 7021 dark grey satin finish

4.8 drawings of front panel of arch - french network version

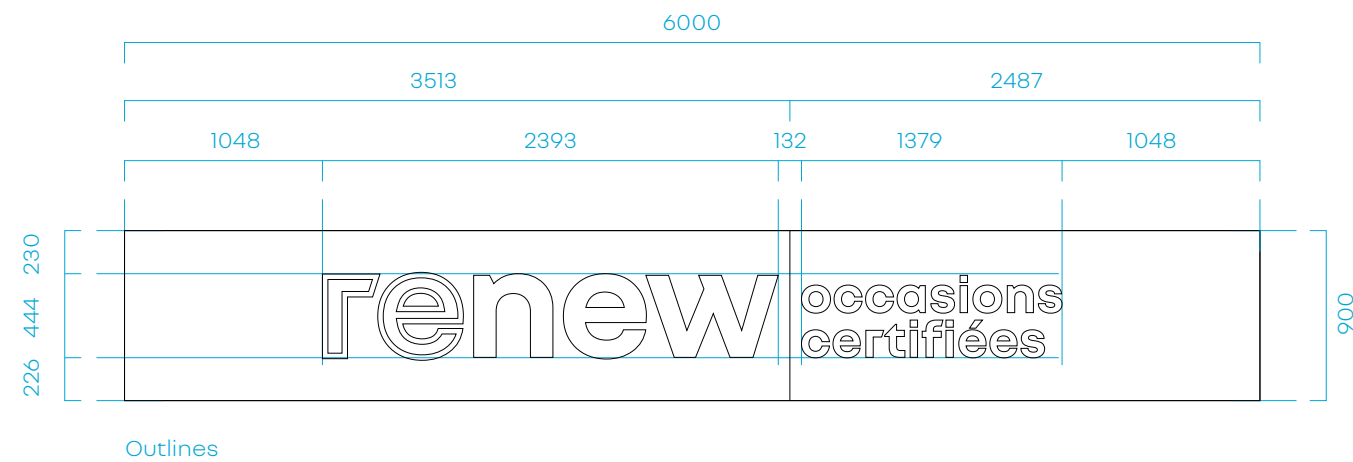

key

- 1 Complete signature in white PMMA, integration in marquetry flush to the surface
- 2 Front face divided in 2 parts, aluminium sheeting, RAL 7021 dark grey satin finish
- 3 Back face divided in 2 parts, aluminium sheeting, RAL 7021 dark grey satin finish

4.9 lighting of arch

description

The face is lit with chain LEDs.

The converter is mounted inside the box.

Performance characteristics

Chain LED with minimum IP65 protection rating.

Temperature: 6,500° K Cool White.

Mean luminance: 3000 cd/m² with a maximum of 350 cd/m².

The warranty for all LED lighting systems and parts is 5 years, subject to compliance with conditions of use and maintenance.

Light output reduced by 50% after 50,000 hours operation.

Minimum guaranteed lifetime: 50,000 hours.

Supply: 220 volts

12 volt converter with regulated voltage, IP 68 protection.

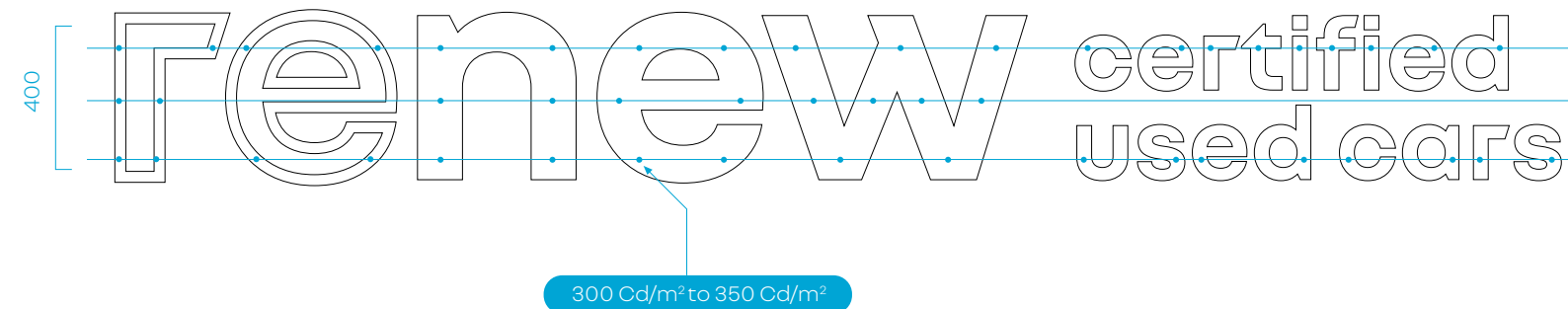

The dots are a schematic representation of the measurement points that should present similar light intensity values in order to obtain even lighting across each of letters.

The readings, performed with a calibrated luminance meter, should ideally be performed without light interference and at a distance of between 1 and 2 m from the letter face.

4.10 installation of lighting

principle

This recommendation is made on the basis of a 20 lumens module with a luminous efficacy of 90 to 100 lumens/watts.

The instruction remains indicative and shall require a validation and a test for compliance with the performance targets indicated in this document.

The LEDs are installed perpendicular to the face. Spacing of the LEDs shall be adjusted to achieve a regular luminous flow on the PMMA face.

description

- Temperature: 6,500° K Cool White.
- Module power rating: 20 lumens
- Luminous efficacy: 90-100 lm/watt
- Converter, 12 volts, constant current
- Number of modules: 90
- Approx. power consumption : 22 watts

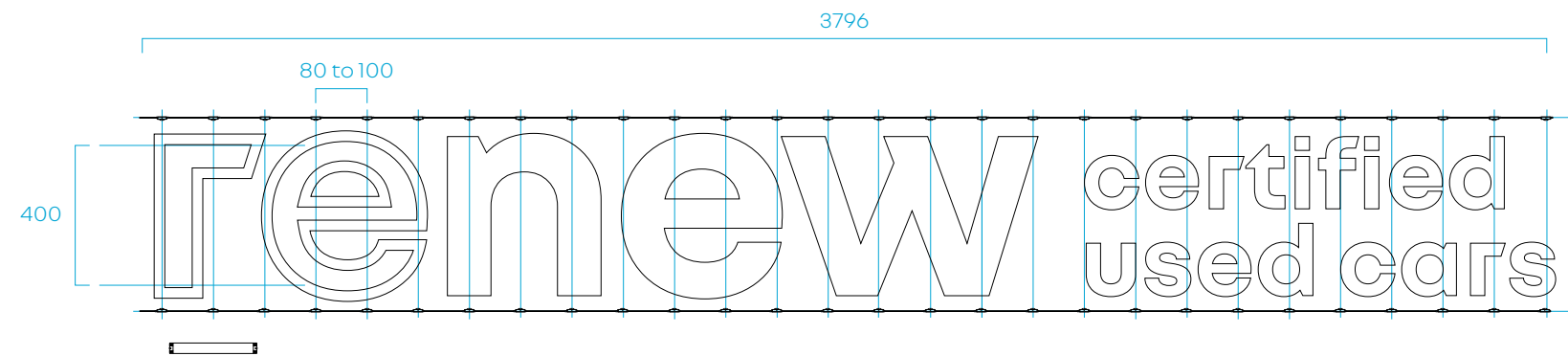

4.11 anchoring of arch

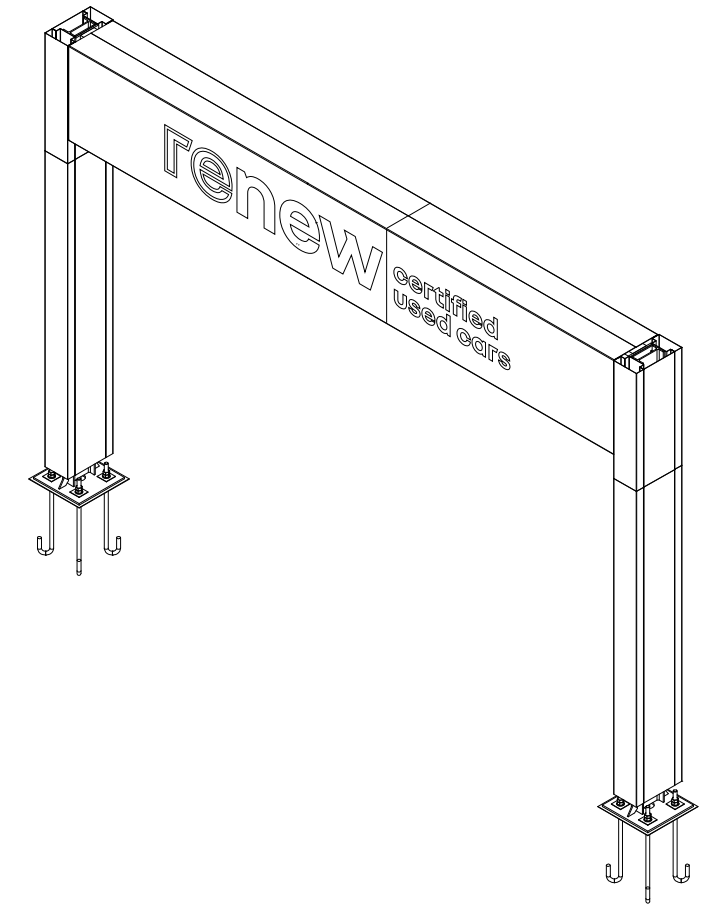
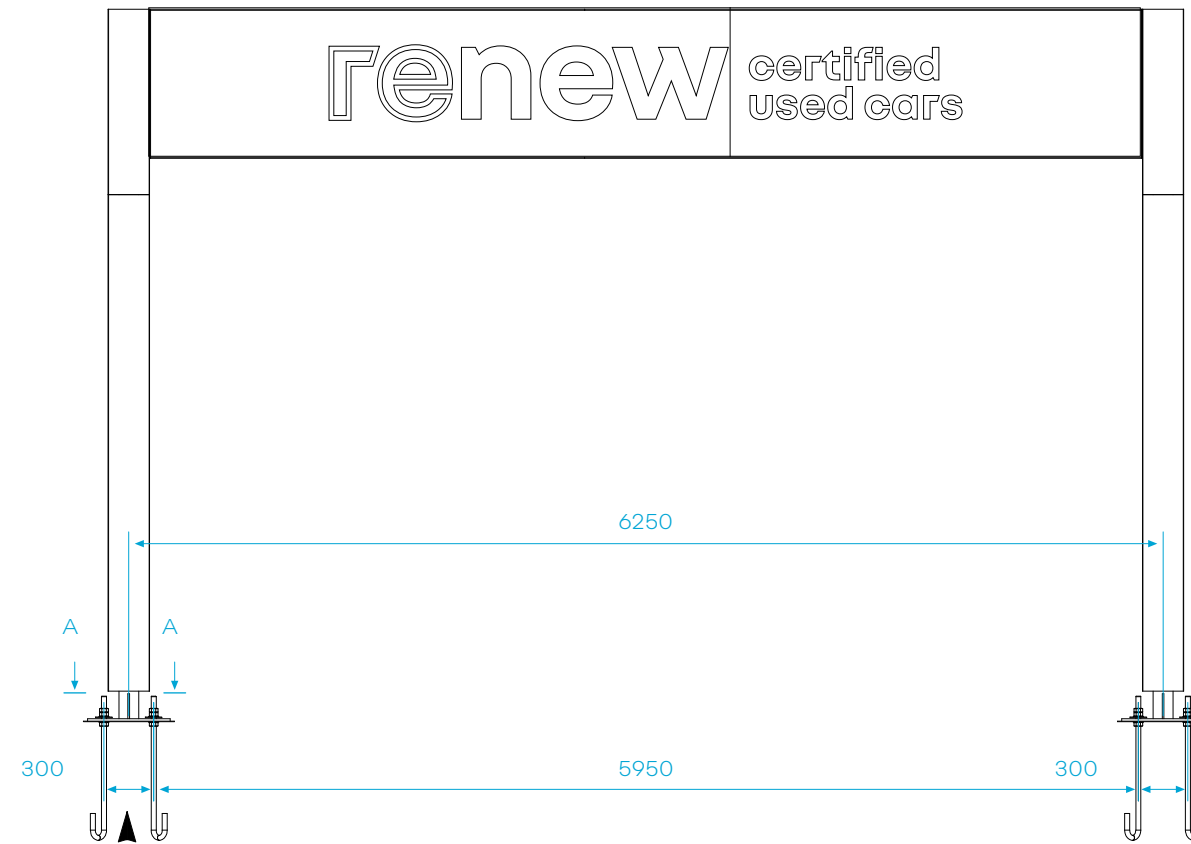

ground attachment system

The arch is anchored to the ground via two plates fitted with four M24 anchoring rods.

The assembly is fastened to a recessed block which is set underground.

Total weight: 1000 kg

- 1 Steel attachment plate
- 2 Central steel structure
- 3 M30 anchoring rods
- 4 Concrete block

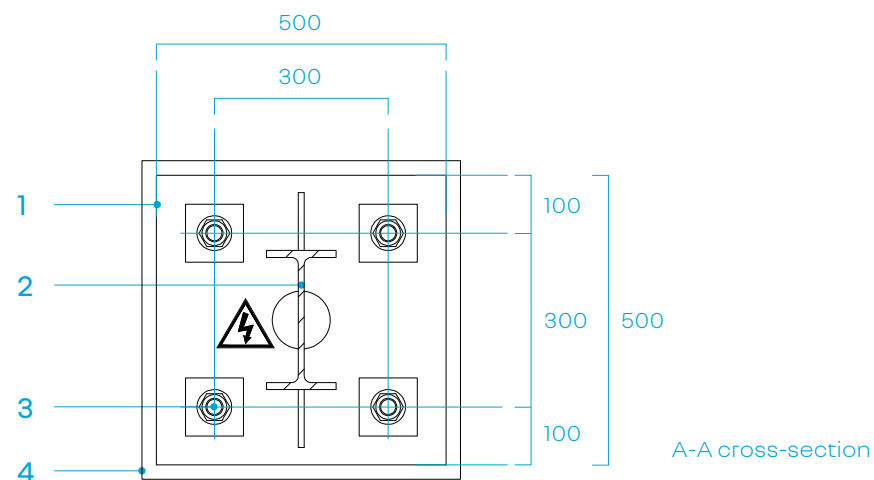

4.12 exploded view of arch

principle

The drawing opposite presents the method for manufacturing the arch.

key

- 1 Vertical galvanized steel frame
- 2 Cladding of the edge of the posts in RAL 9010 white aluminium sheeting with 40% gloss
- 3 Cladding of the structure in pre-lacquered RAL 9010 white aluminium sheeting with 40% gloss
- 4 Horizontal galvanized steel framed with poles
- 5 Front panel in pre-lacquered RAL 7021 dark grey aluminium sheeting with 40% gloss
- 6 Lettering in light-diffusing white PMMA integration in marquetry flush to the surface
- 7 Back panel in pre-lacquered RAL 7021 dark grey aluminium sheeting with 40% gloss

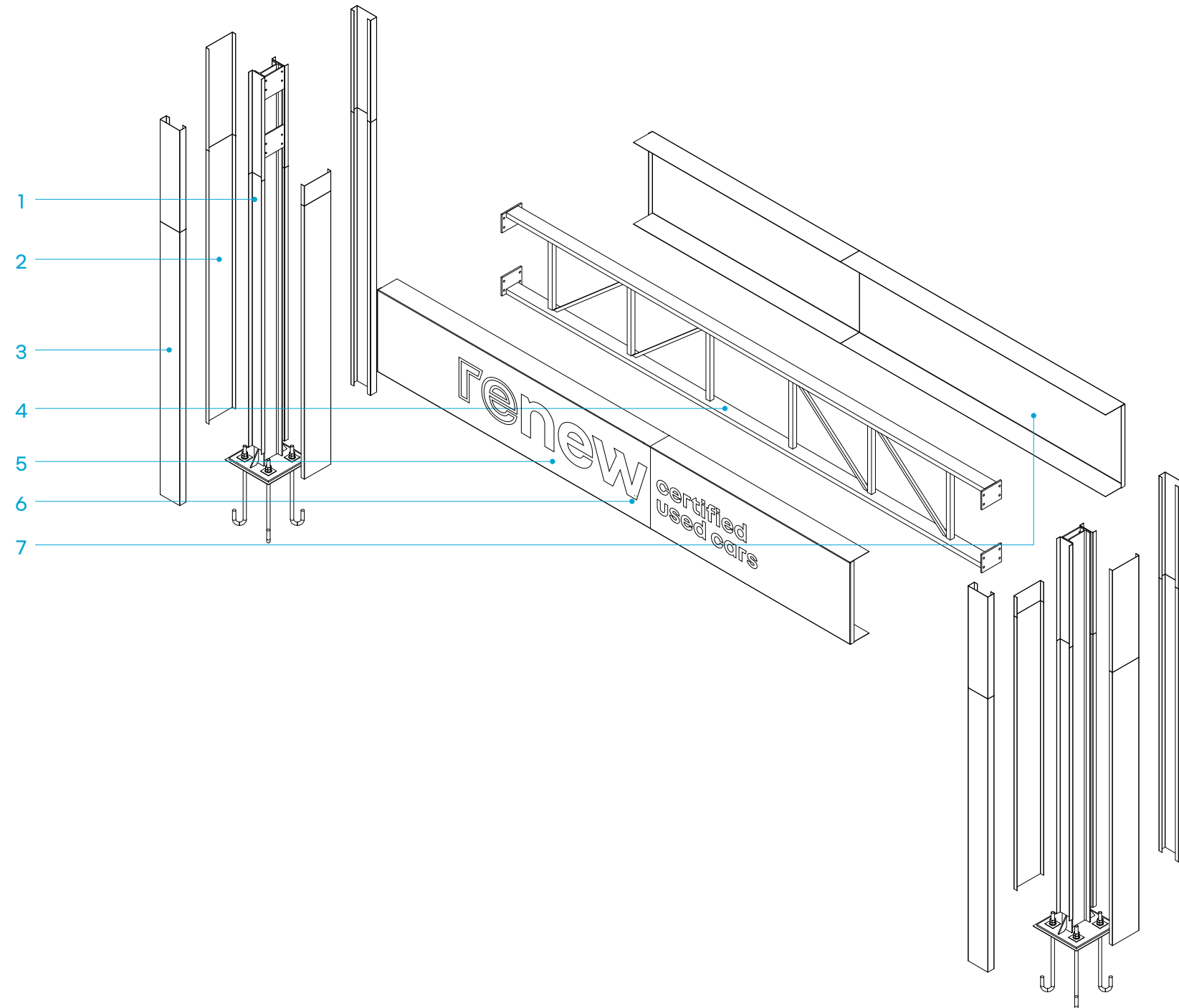

4.13 retrofit of an existing arch

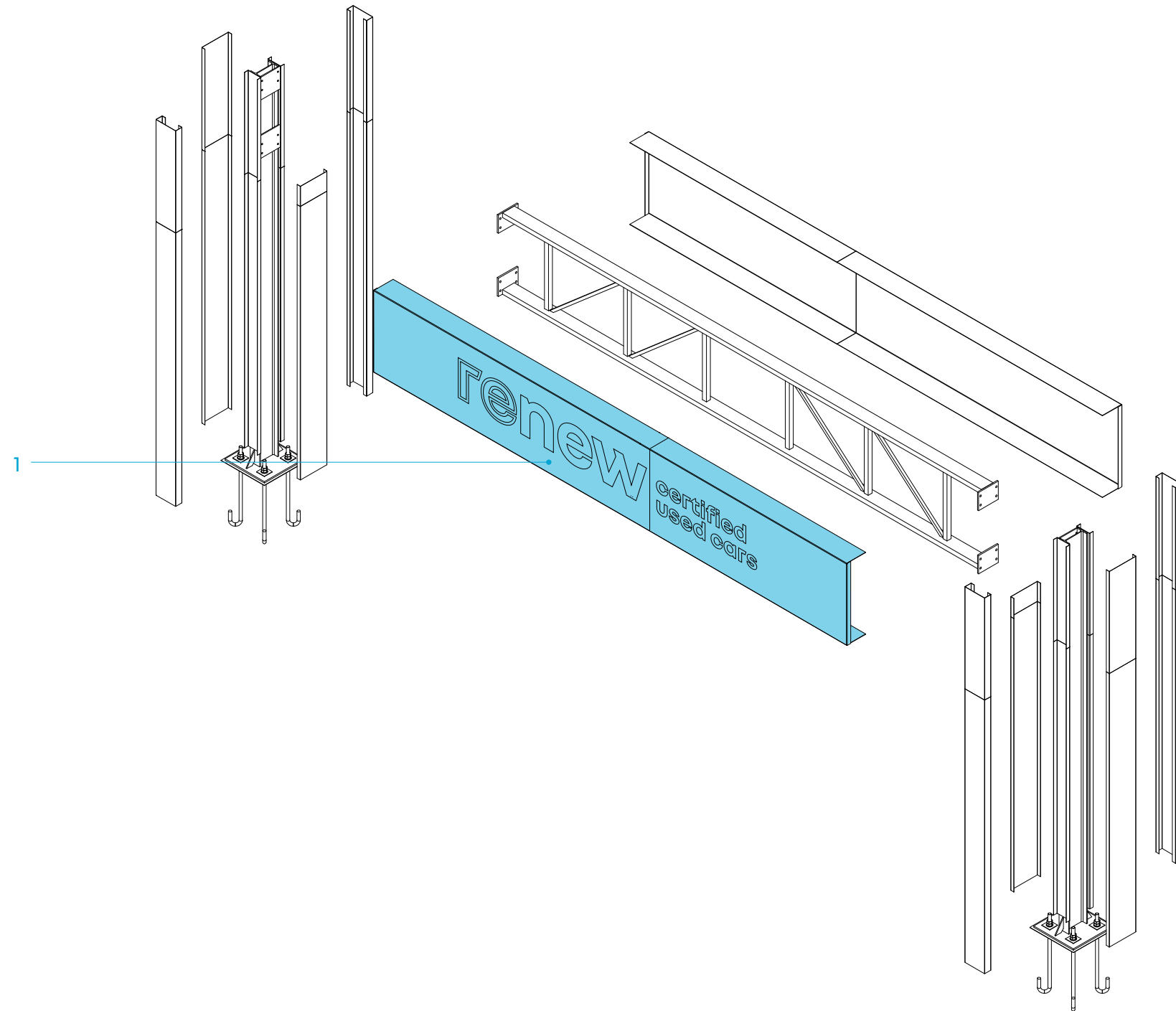

principle

It is recommended to retrofit the existing archs.

For this, it will be necessary to remove the front face (including lighting) and to replace it on site with new elements with the new complete signature.

key

- 1 Front panel in pre-lacquered RAL 7021 dark grey aluminium sheeting with 40% gloss with renew signature in white PMMA.

4.14 promotional sign

principle

The promotional sign displays a message explaining the renew customer promise.

This sign is installed at the entry to the exterior display area in front of the first vehicle on display.

The content is to be adapted by the Country with the approval of the renew corporate

- 1 Front face with an example of promotional image printed on adhesive



4.15 details of front panel of promotional sign



TOP

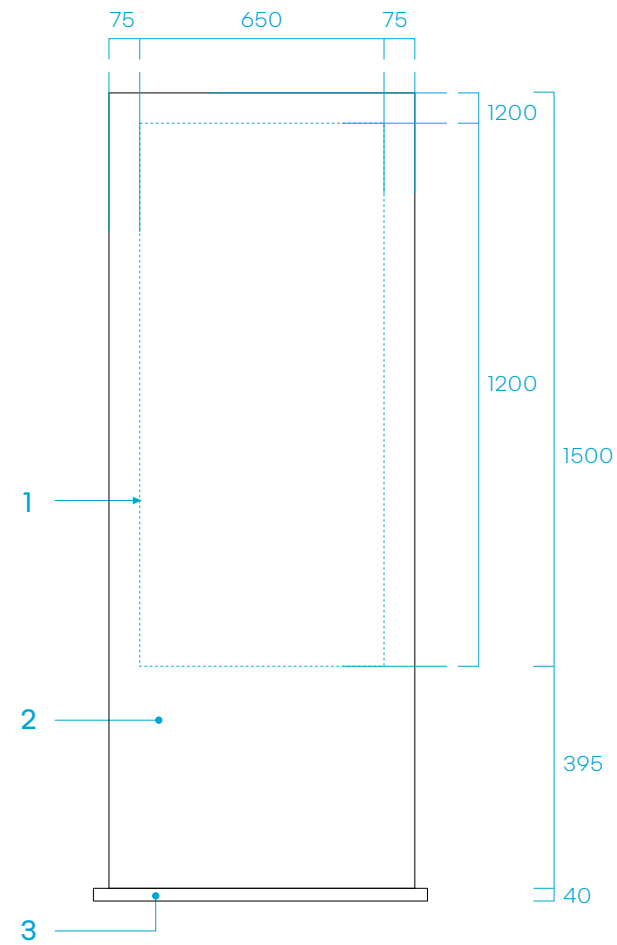

FRONT

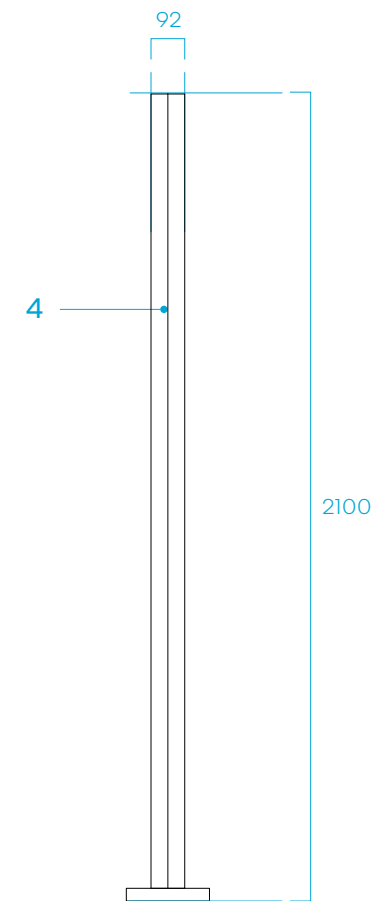

SIDE

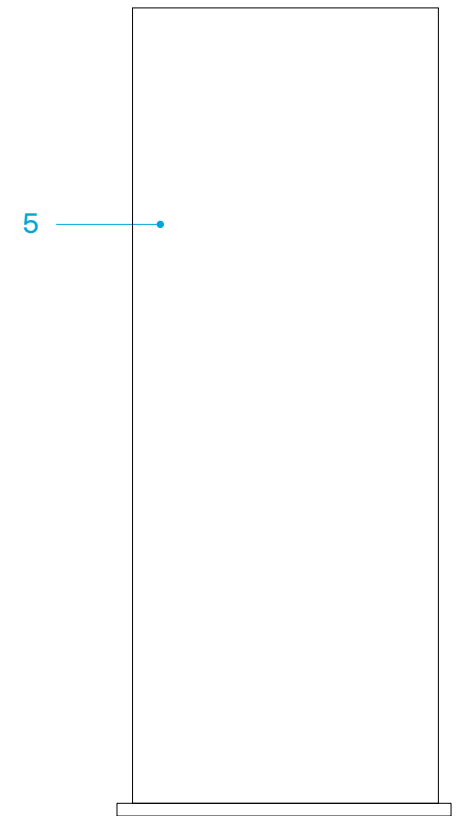

BACK

key

- 1 Limit of text and image
- 2 Front face in aluminium sheeting covered with white printed adhesive
- 3 RAL 7021 dark grey satin finish background
- 4 Sides in aluminium sheeting
- 5 Back in aluminium sheeting

4.16 anchoring of promotional sign

ground attachment system

The sign is anchored to the ground via two plates fitted with two M12 anchors.

The assembly is covered with a attachment plate concealer allowing access to fastenings in order to facilitate replacement in case of damage.

- 1 Aluminium plate
- 2 Central aluminium structure
- 3 Aluminum attachment plate concealer
- 4 Steel anchor M12

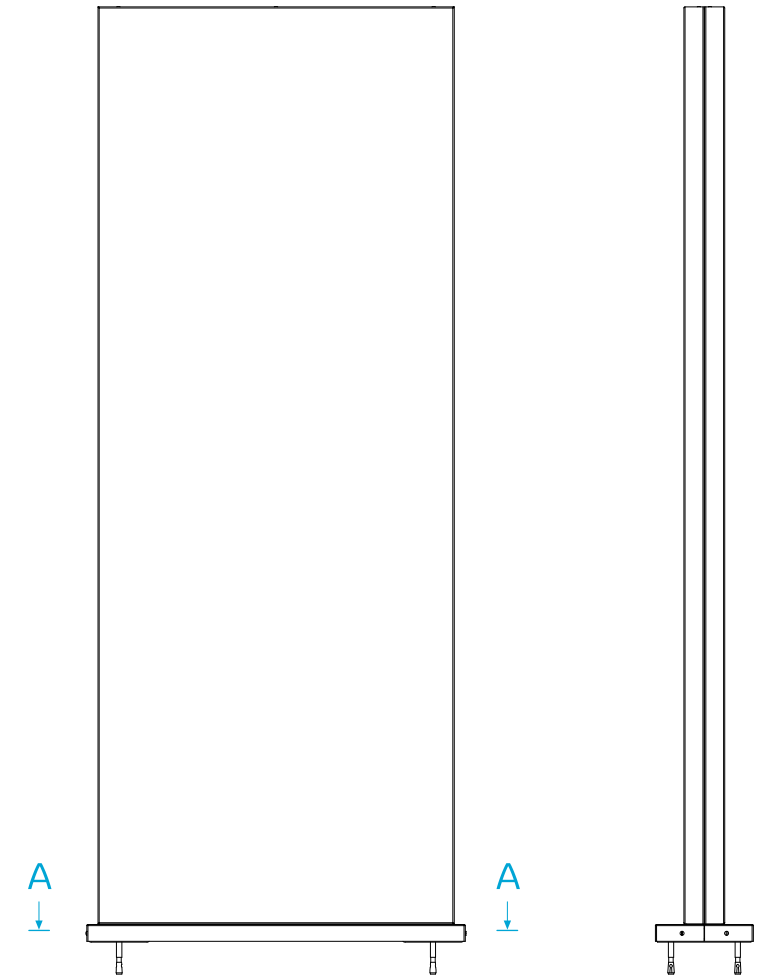
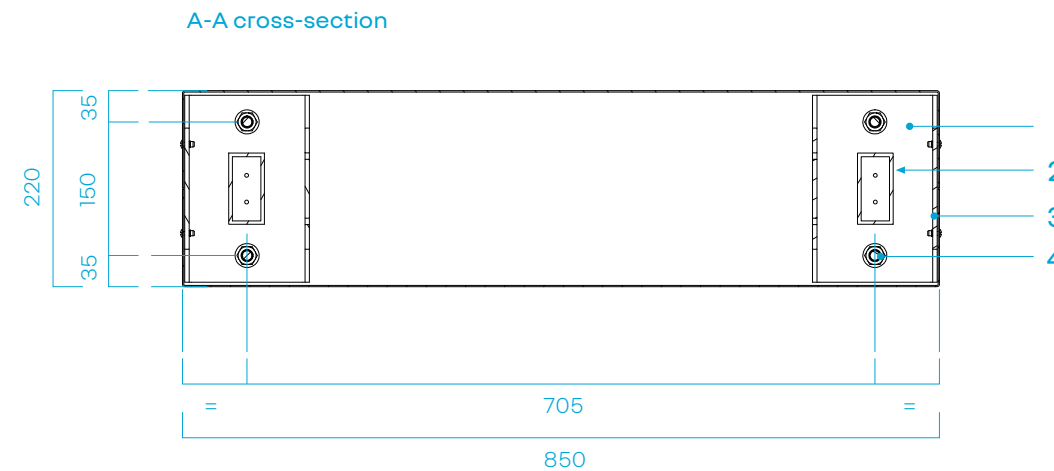

4.17 exploded view of promotional sign

principle

The drawing opposite presents the method for manufacturing promotional sign.

- 1 Natural finish aluminium frame
- 2 Attachment plate concealers in RAL 7021 dark grey aluminium sheeting with 40% gloss satin finish
- 3 Panels in RAL 7021 dark grey aluminium sheeting with 40% gloss satin finish
- 4 Natural finish aluminium profiles

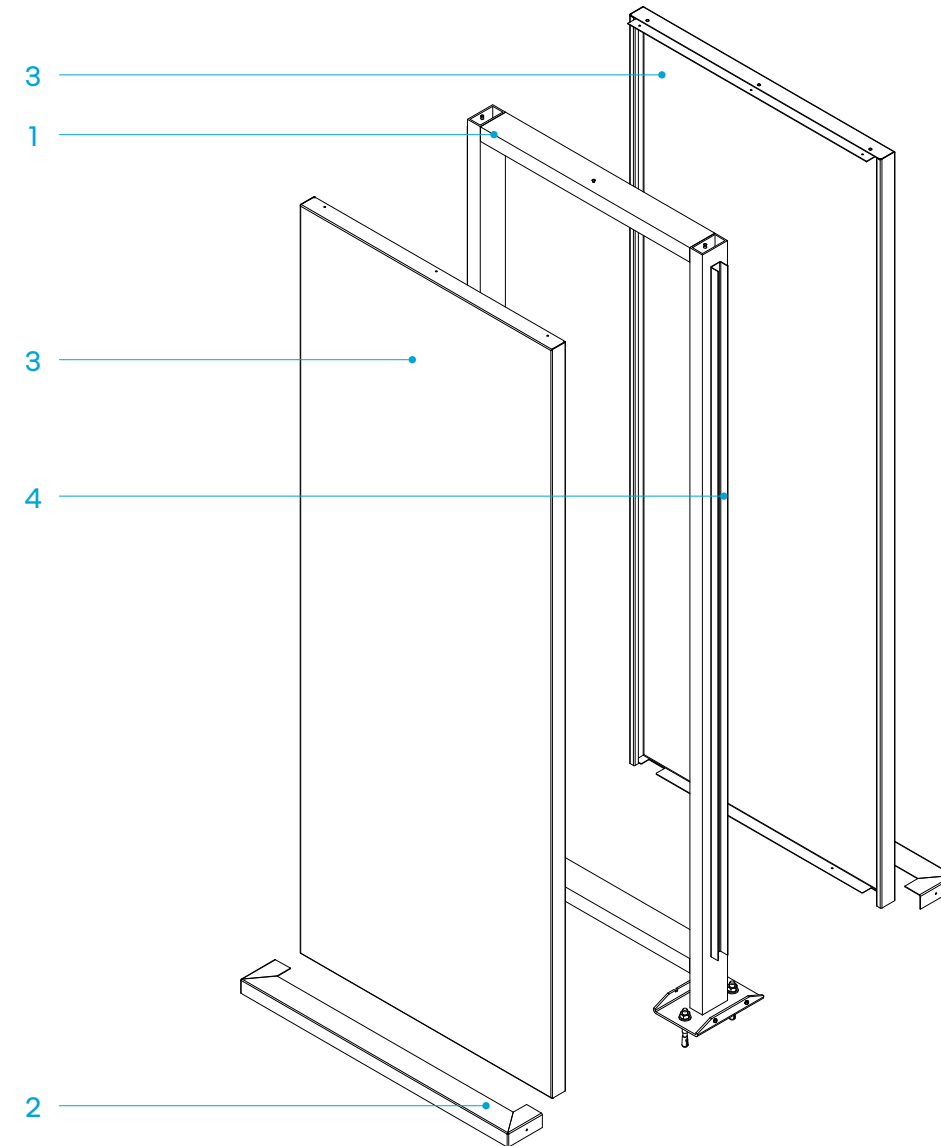

4.18 retrofit of an existing promise sign

principle

It is recommended to retrofit the existing promise signs.

For this, it will be necessary to remove the right item (including anchoring).

The adhesive on the front face of the existing left element will be replaced on site with a new adhesive covering the whole face.

- 1 Printed white adhesive

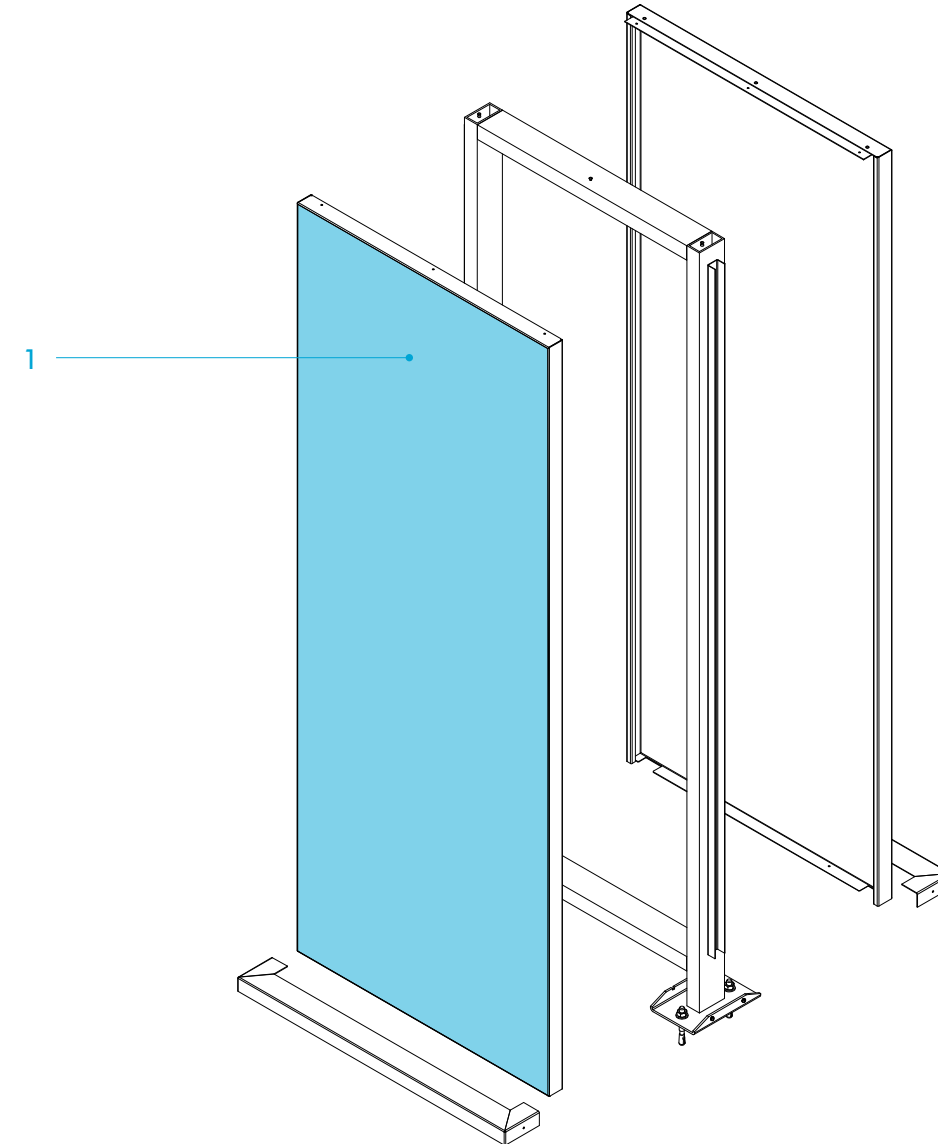

4.19 generic standards

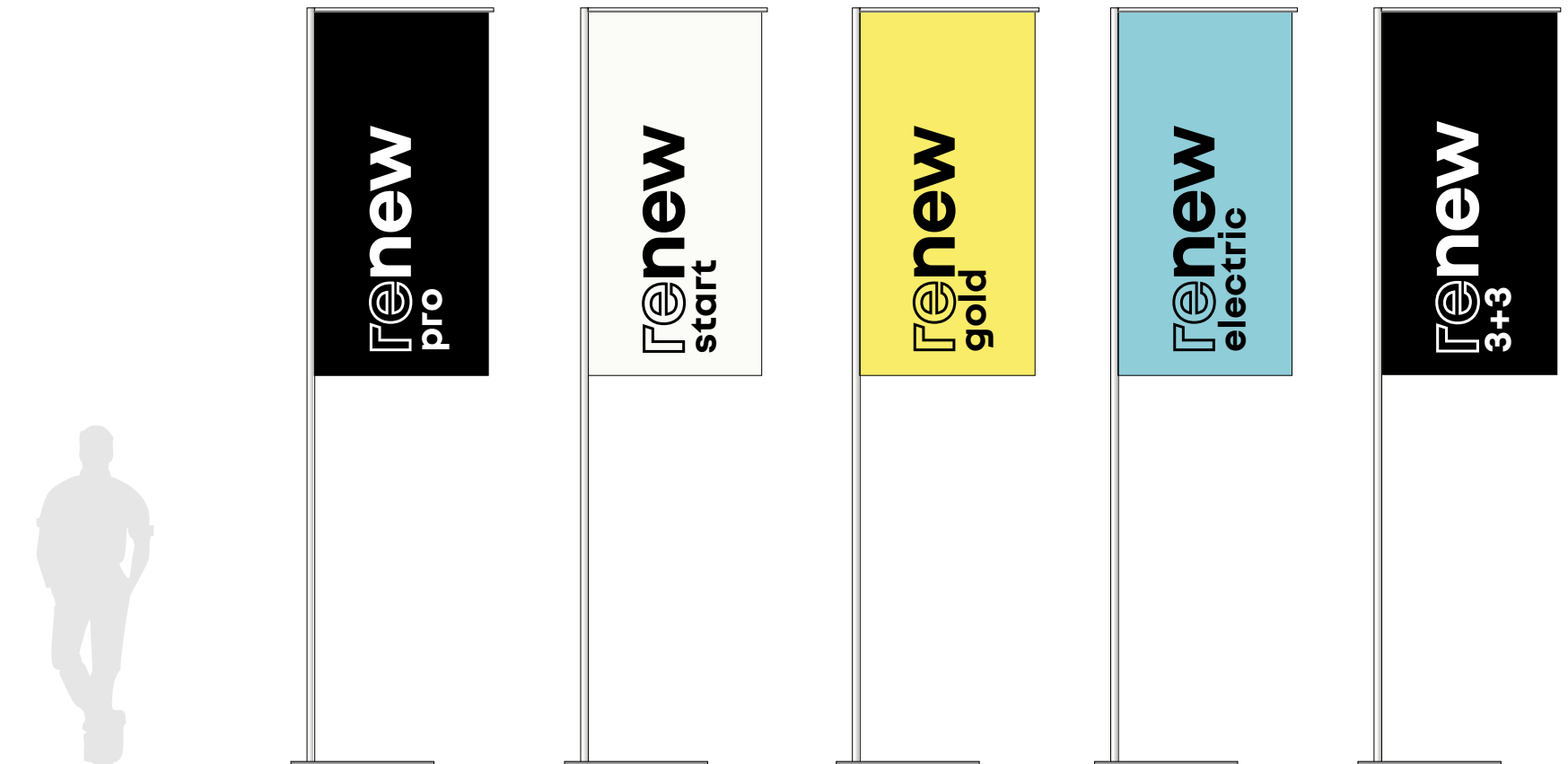

description

Generic standards serve the purpose of organizing and dividing up the renew display area into segments.

There are various possible options.

They replace the previous bay signs.



black ink



blue pantone 636 c



yellow pantone 3955 c

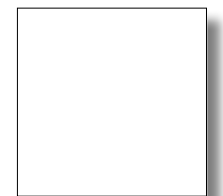

white polyester fabric

4.20 generic standards - outlines

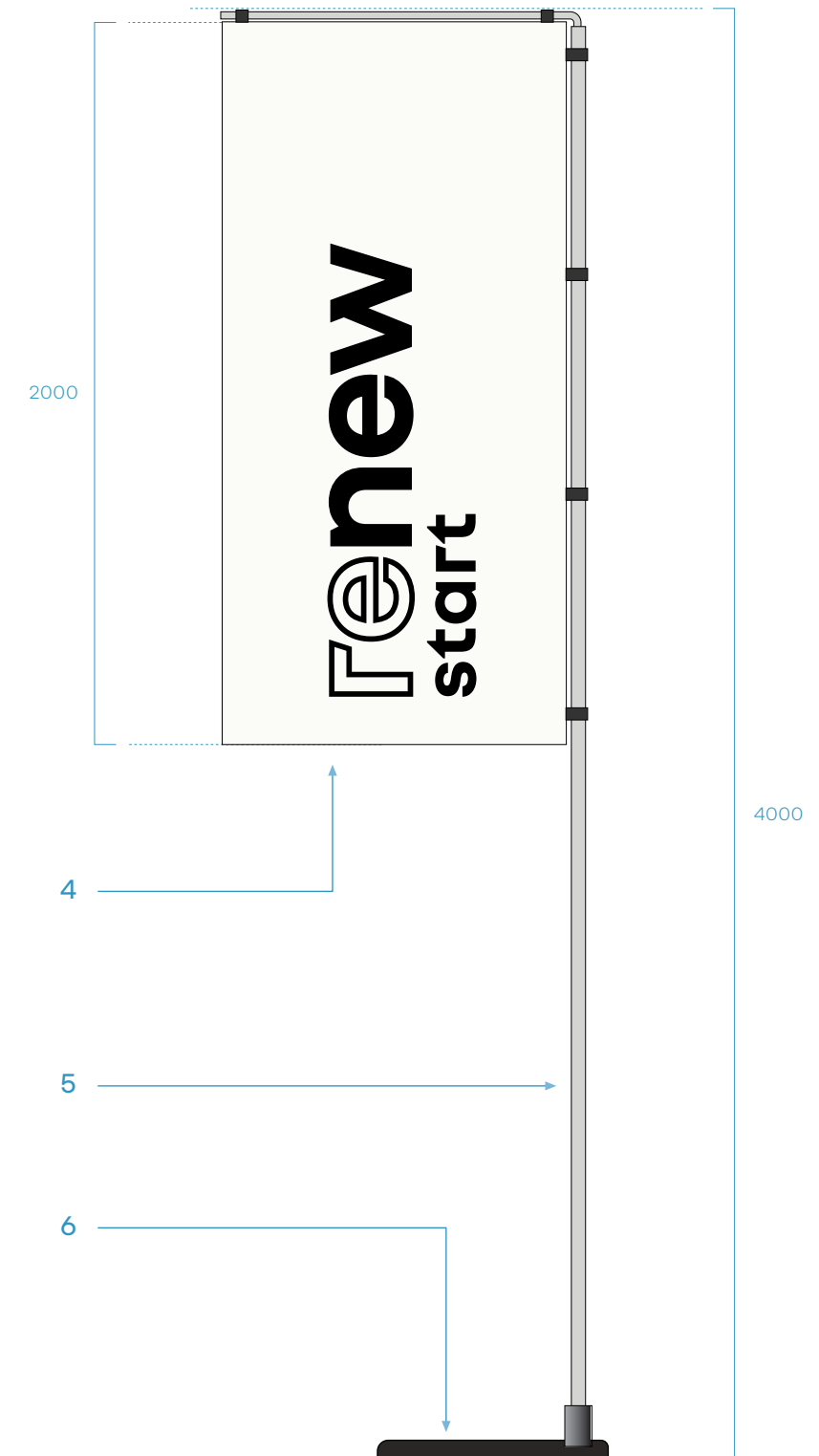
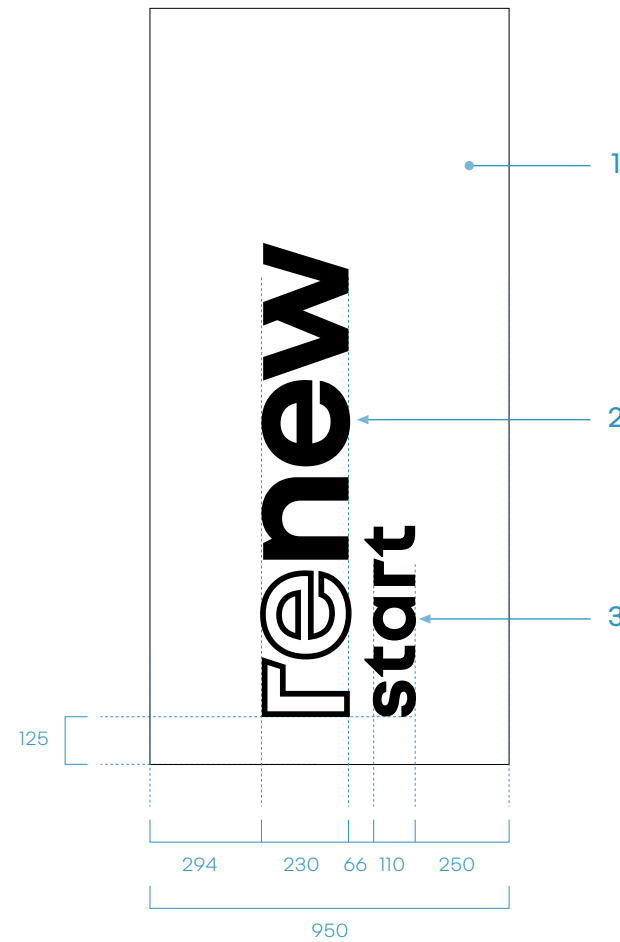

description

- 1 White background made with 115g/m² polyester fabric
- 2 renew signature.
- 3 name of segment on 1 line, in nouvel 'R bold typeface, aligned on bottom, lowercase.
- 4 banner.
- 5 telescopic aluminium mast d. 30mm.
- 6 black base.

4.21 promotional standards

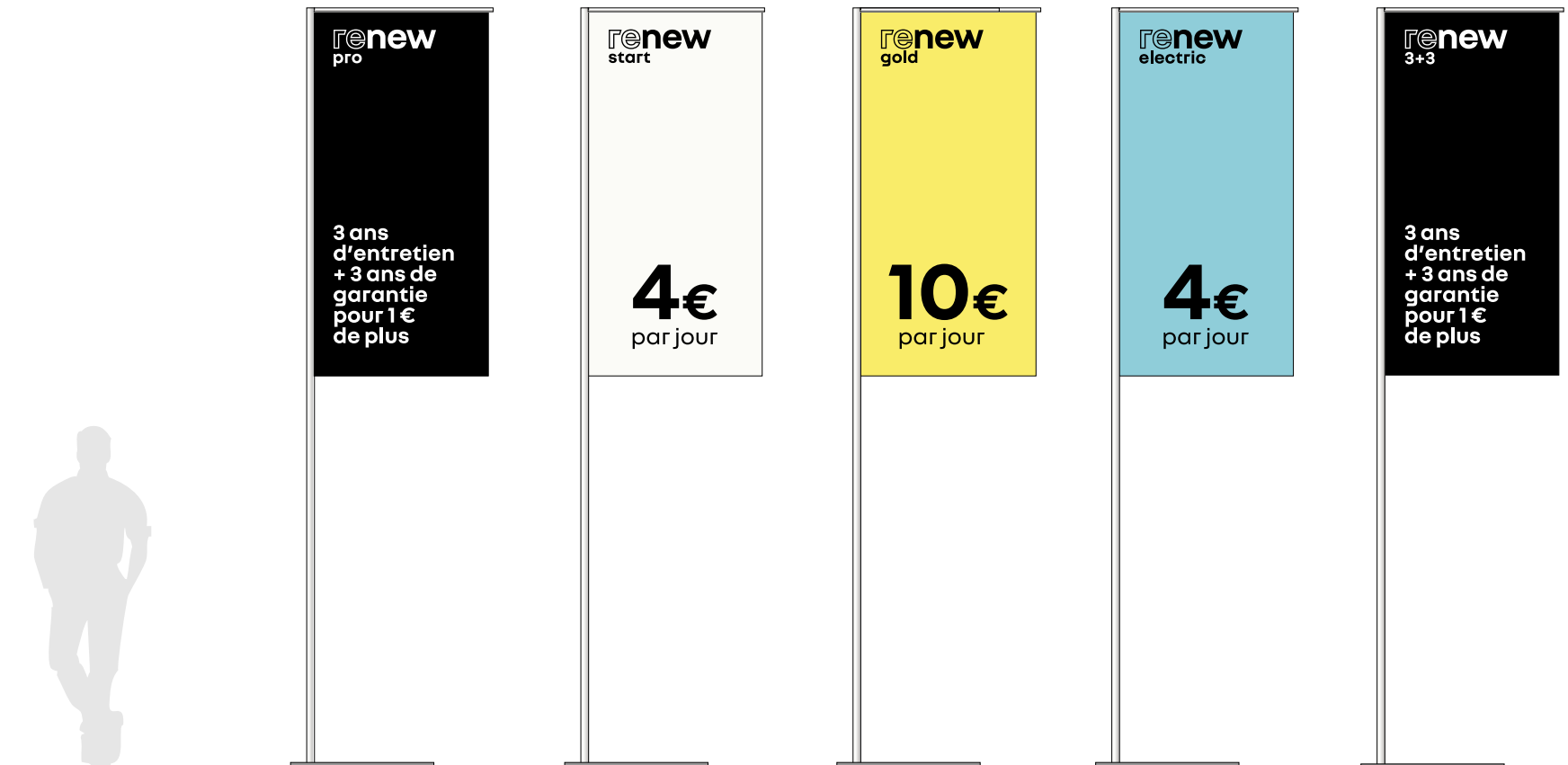

description

Promotional standards enliven the areas of the exhibition by presenting different promotional messages corresponding to the segments.



black ink



blue pantone 636 c



yellow pantone 3955 c

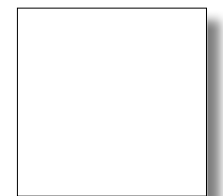

white polyester fabric

4.22 generic standards - outlines 1

description

- 1 renew signature.
- 2 name of segment on 1 line, in nouvel 'R bold typeface, aligned on bottom.
- 3 White background made with 115g/m2 polyester fabric
- 4 centred text, in nouvel 'R typeface.
- 5 centred text, in nouvel 'R bold typeface.
- 6 banner.
- 7 telescopic aluminium mast d. 30mm.
- 8 black base.

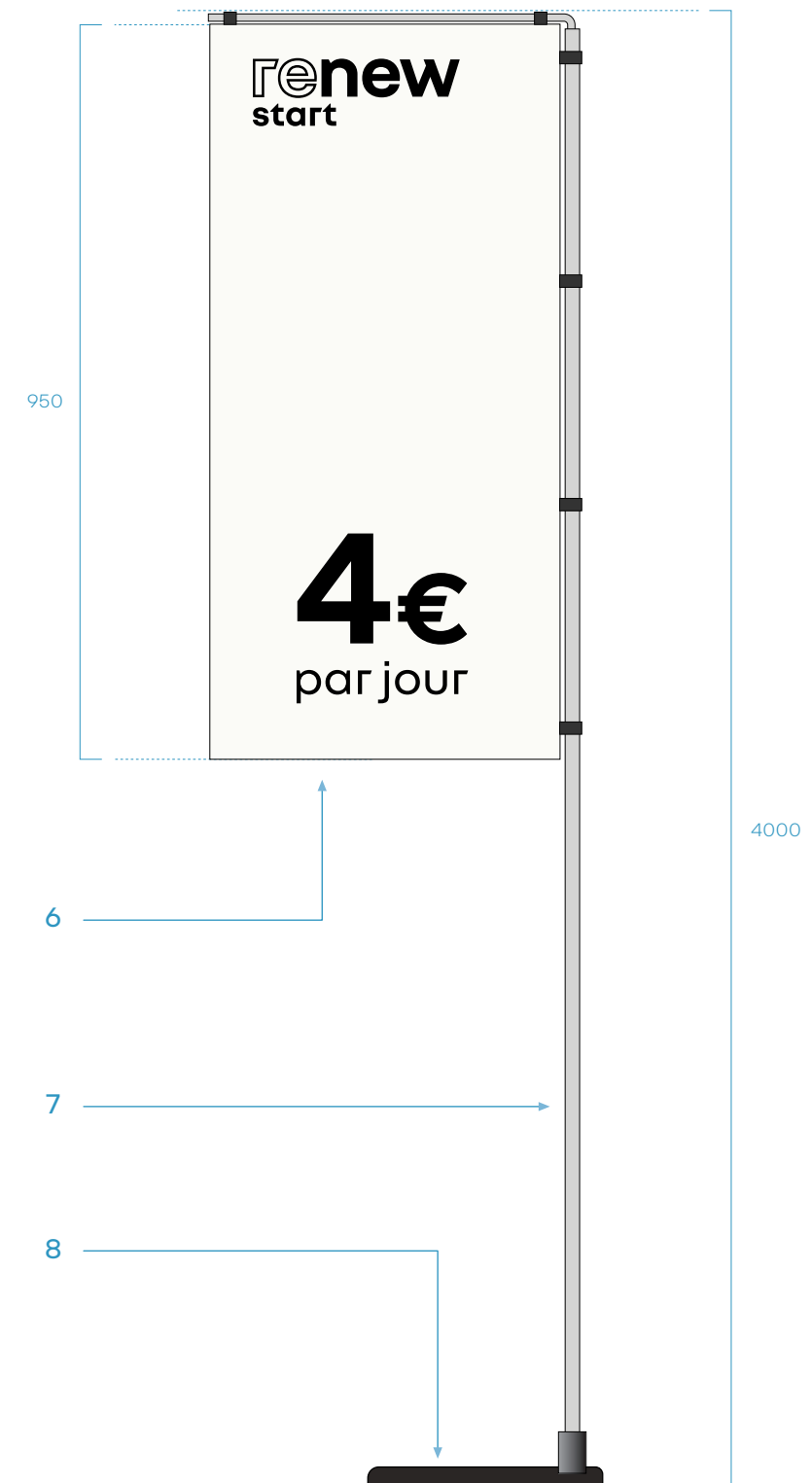
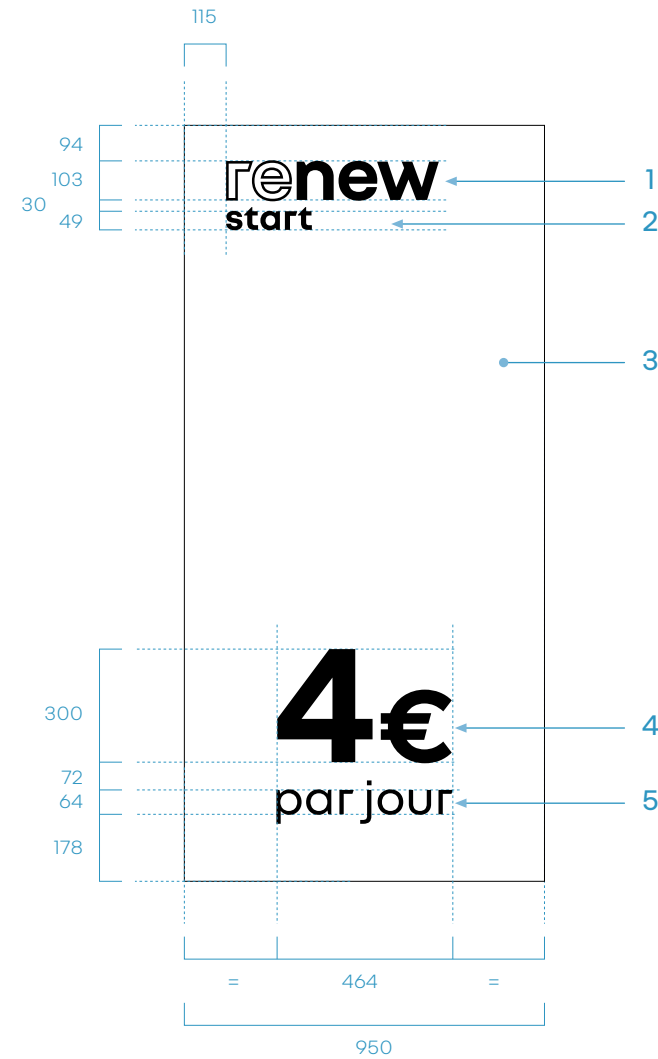

4.23 generic standards - outlines 2

**renew
pro**

**renew
start**

**renew
gold**

**renew
electric**

**renew
3+3**

description

- 1 renew signature.
- 2 name of segment on 1 line, in nouvel 'R bold typeface, aligned on bottom.
- 3 White background made with 115g/m2 polyester fabric
- 4 left-aligned texts, in nouvel 'R bold typeface.
- 5 banner.
- 6 telescopic aluminium mast d. 30mm.
- 7 black base.

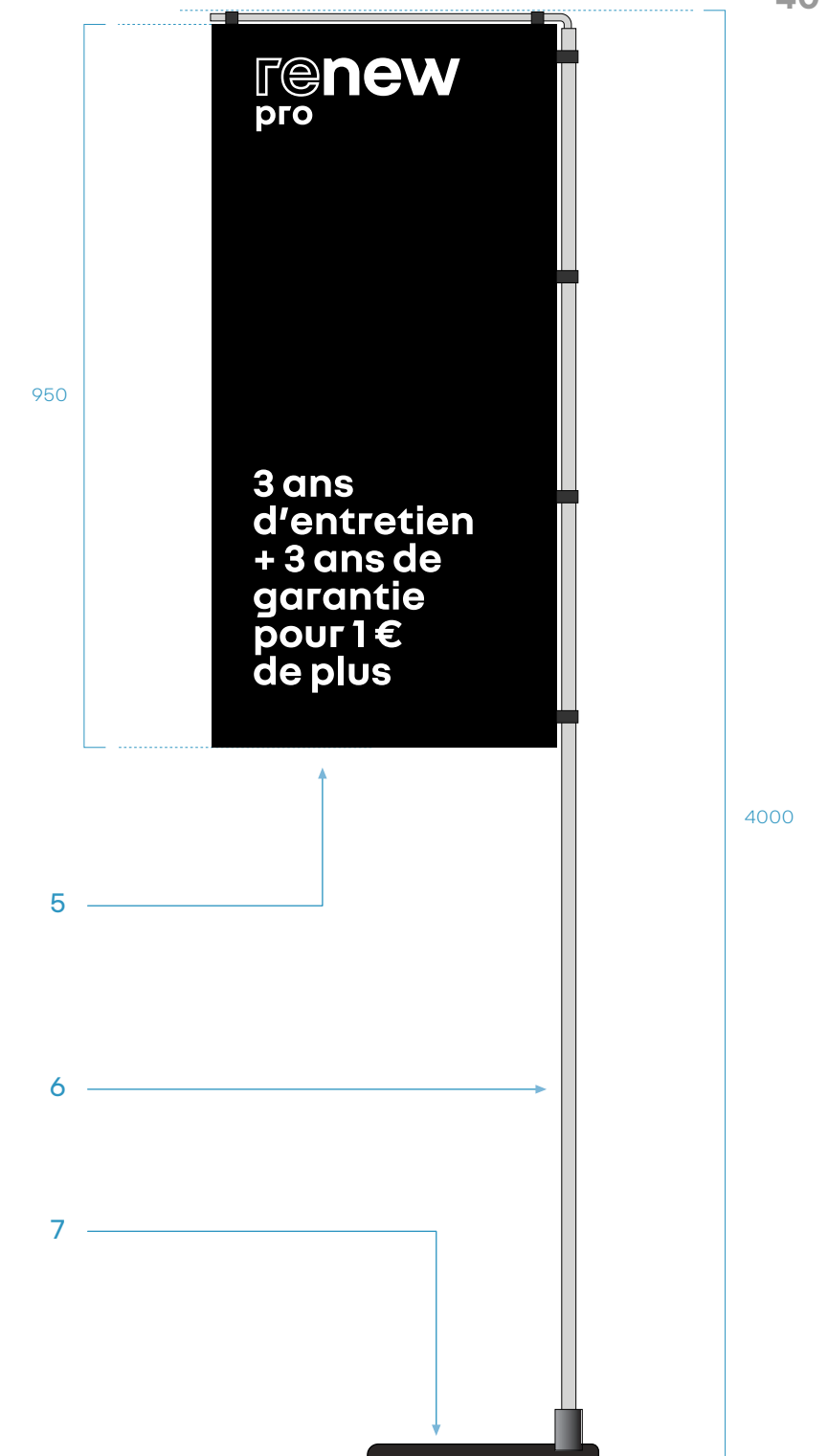
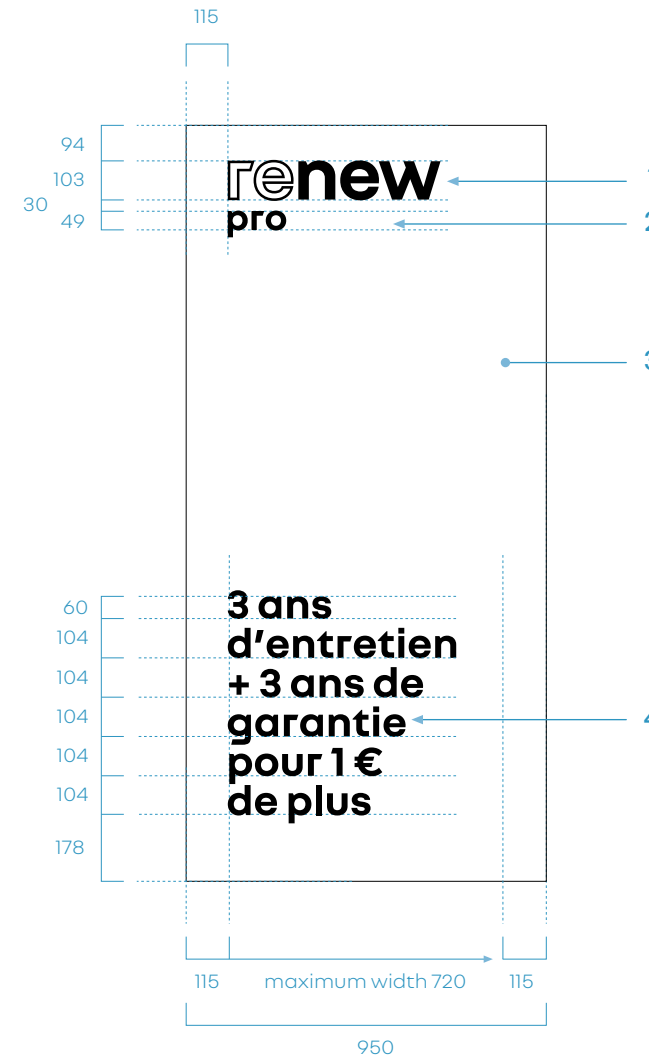

4.24 bay signs

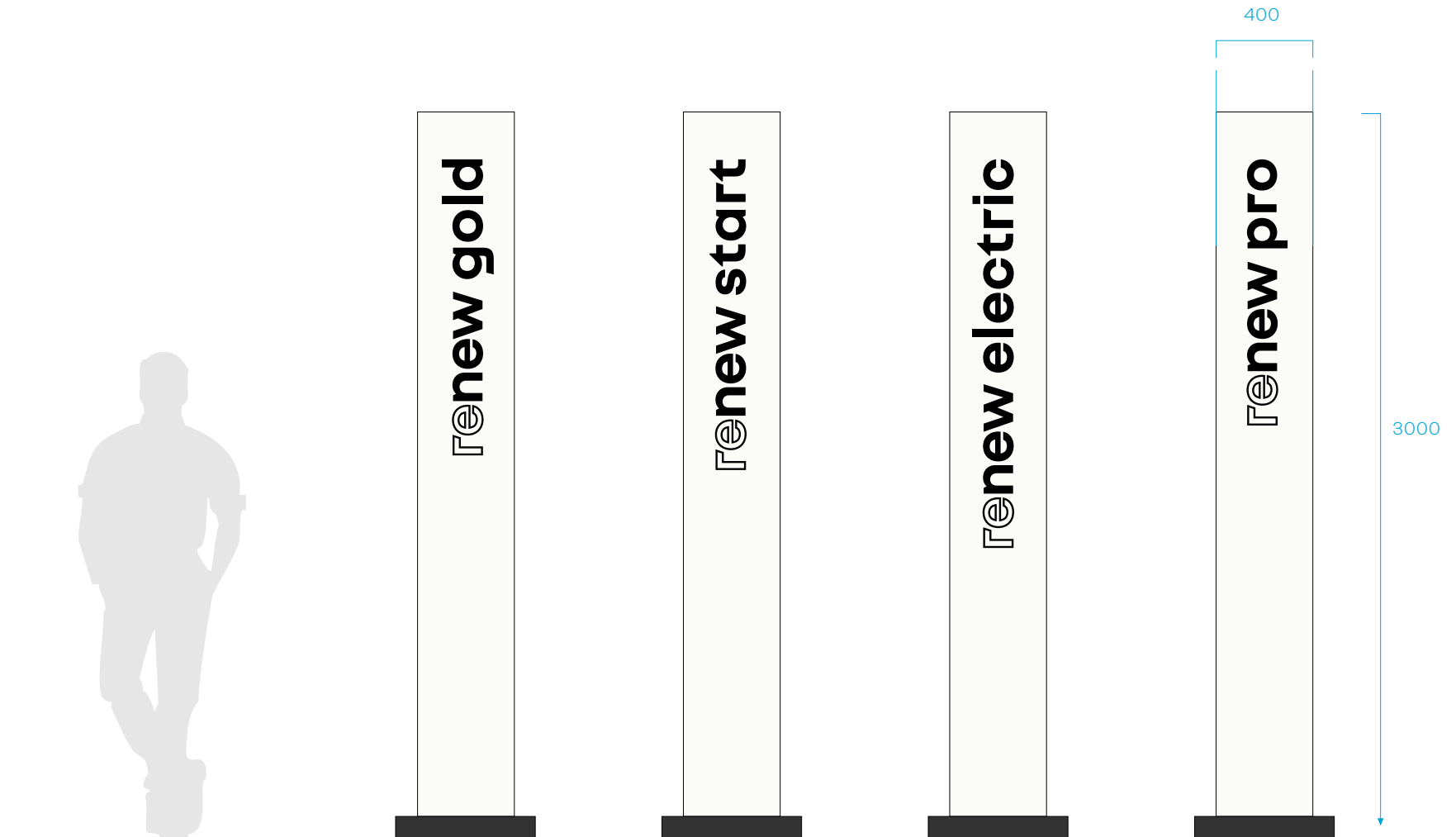

principle

The bay signs have been installed previously in some renew exterior area.

Their faces can be retrofitted to adopt the new identity visual of segments.

4.25 outlines of the face of bay signs

key

- 1 Panel in pre-lacquered RAL 9010 satin white aluminium sheeting
- 2 Matt black adhesive markings, nouvel'R Bold typeface, top-aligned, tracking 100%
- 3 Matt black adhesive markings, nouvel'R typeface, tracking 100%

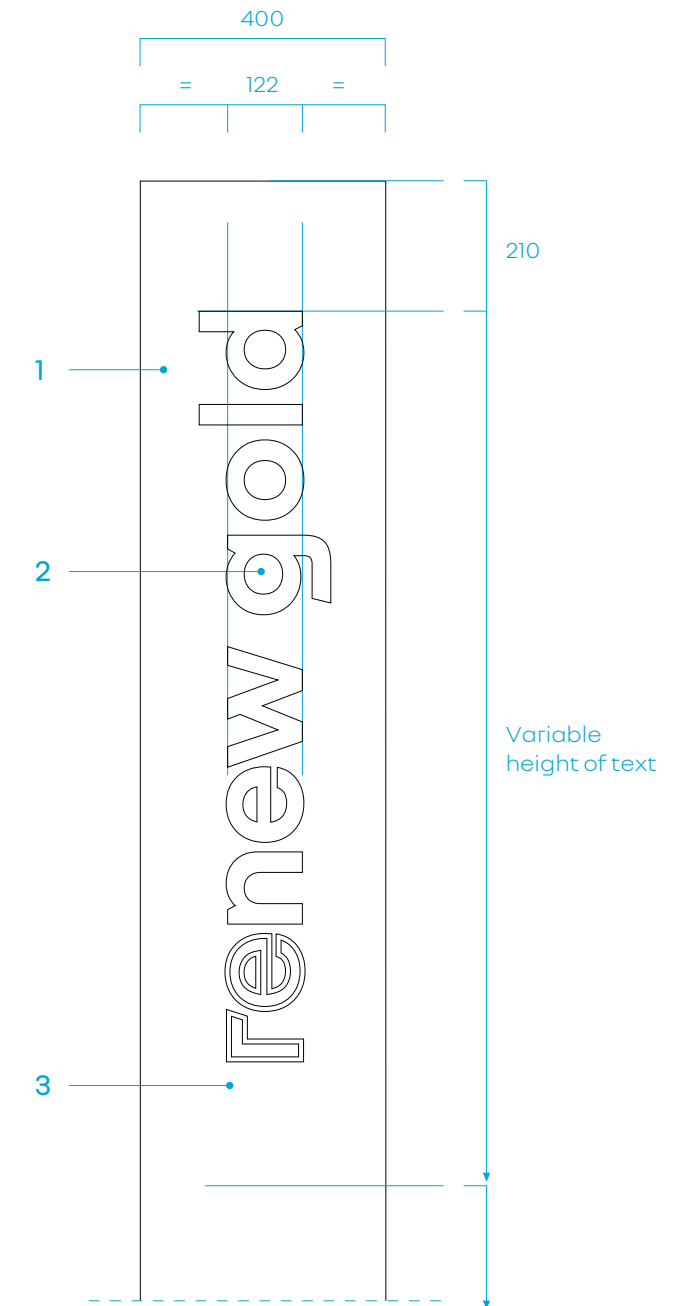
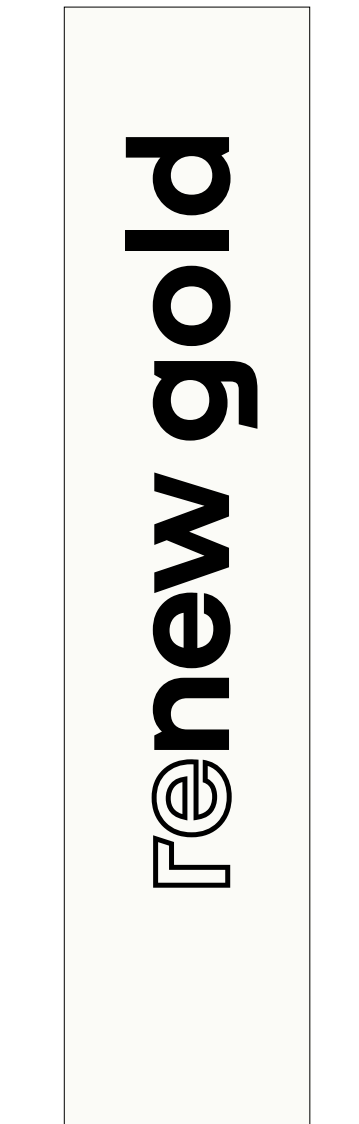

4.26 retrofit of bay signs

principle

It is recommended to retrofit the existing bay signs.

For this, it will be necessary to remove the existing adhesive on faces and to replace them on site with new adhesive texts.

- 1 Black adhesive lettering

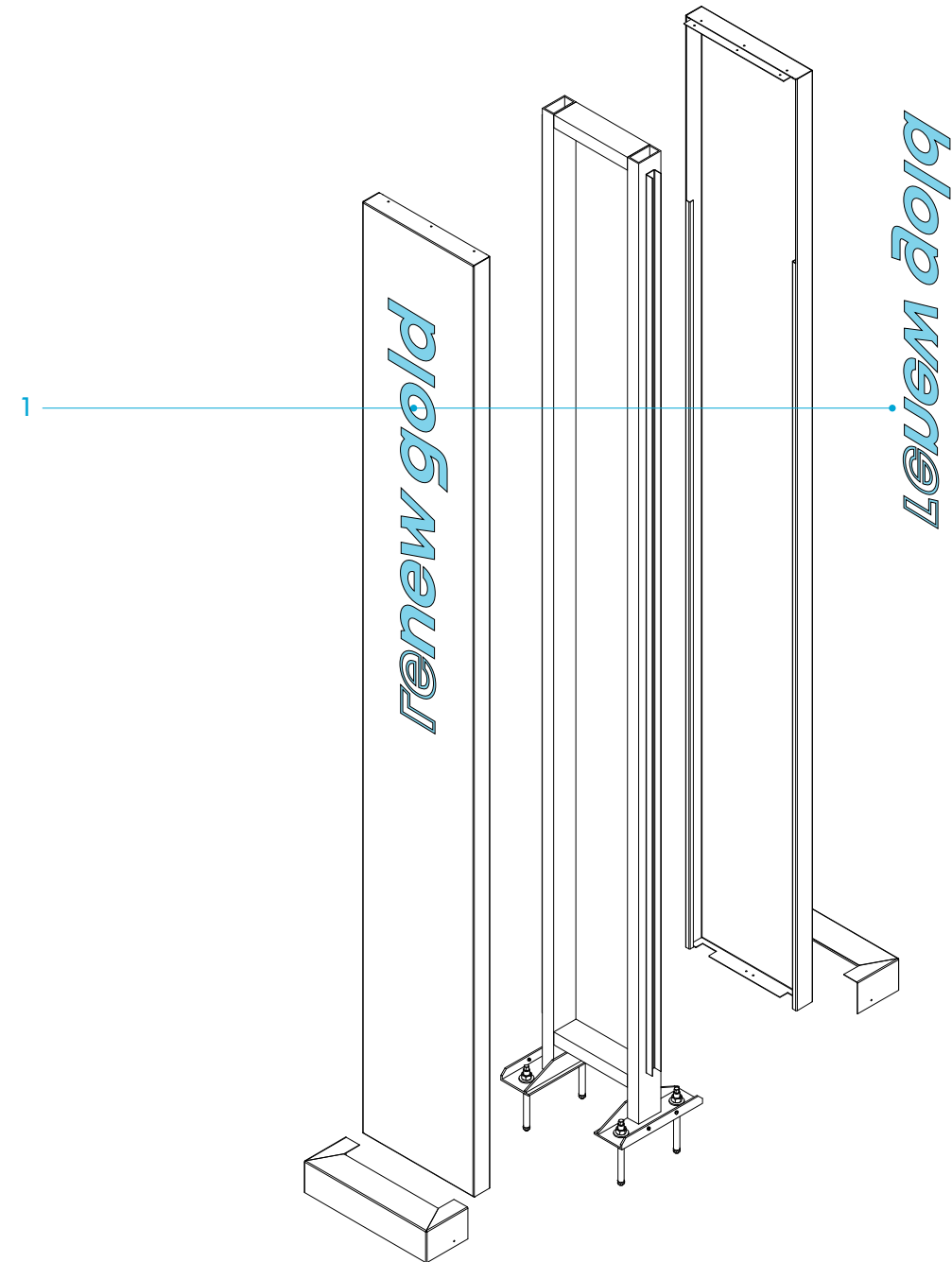

4.27 overview of lighting mast

principle

The lighting mast is comprised of a steel frame with cladding in dark grey aluminium sheeting. It is 4,300 mm in height.

The upper section features a spotlight built into an arm with an offset of 700 mm, pointing towards the interior of the central bay.

Pointing towards the exterior of the bay, another spotlight is built into the mast at a height of 3,000 mm from the ground to illuminate access aisles between the central bay and the vehicles on display.

To ensure that renew are well-lit, it is important to choose an asymmetric lens which allows light to be well-distributed across the entire zone.

- 1 Spotlight Yaki Larvik Slim 50 watts
- 2 Cladding in pre-lacquered RAL 7021 dark grey aluminium sheeting with 40% gloss satin finish

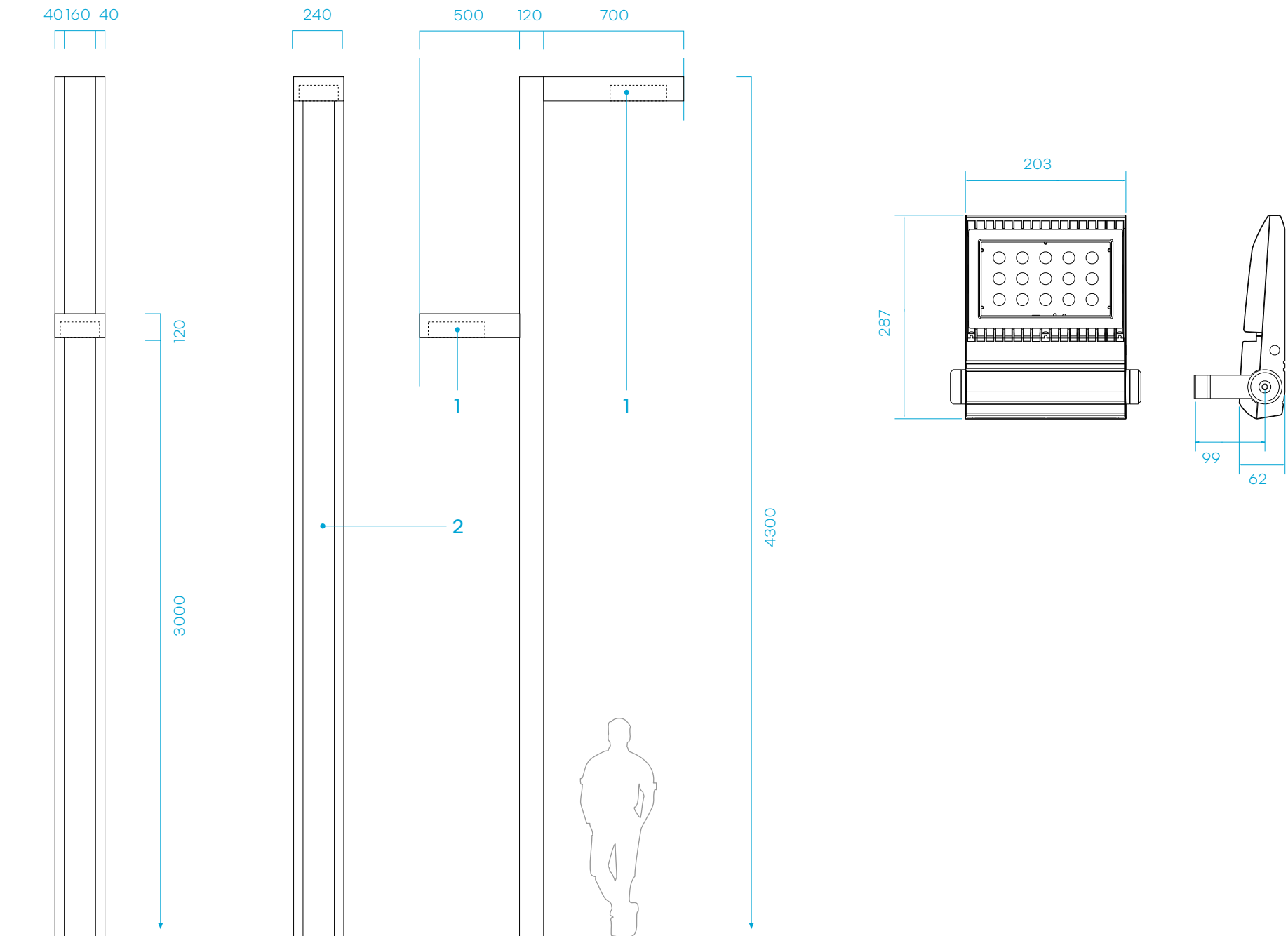

4.28 lighting of zone

principle

Each vehicle located in the central bay is lit by 2 lighting masts installed in the axis of the display bay.

characteristics

Asymmetric lenses:

- 30 x 90° at the top (20° incline)
- 85 x 135° at the bottom (20° incline)

Colour temperature: 4,000 K Colour rendering index: Ra > 80

Luminous flux of module: > 5,700 lm

Light source efficiency: > 100 lm/w

Protection index: > IP 67

Energy consumption: 55 w per spotlight

Finish: Anthracite dark grey or black

Warranty period for all parts: 5 years

Light output reduced by 50% after 50,000 hours operation.

Minimum guaranteed lifetime: 50,000 hours.

Supply: 220 volts

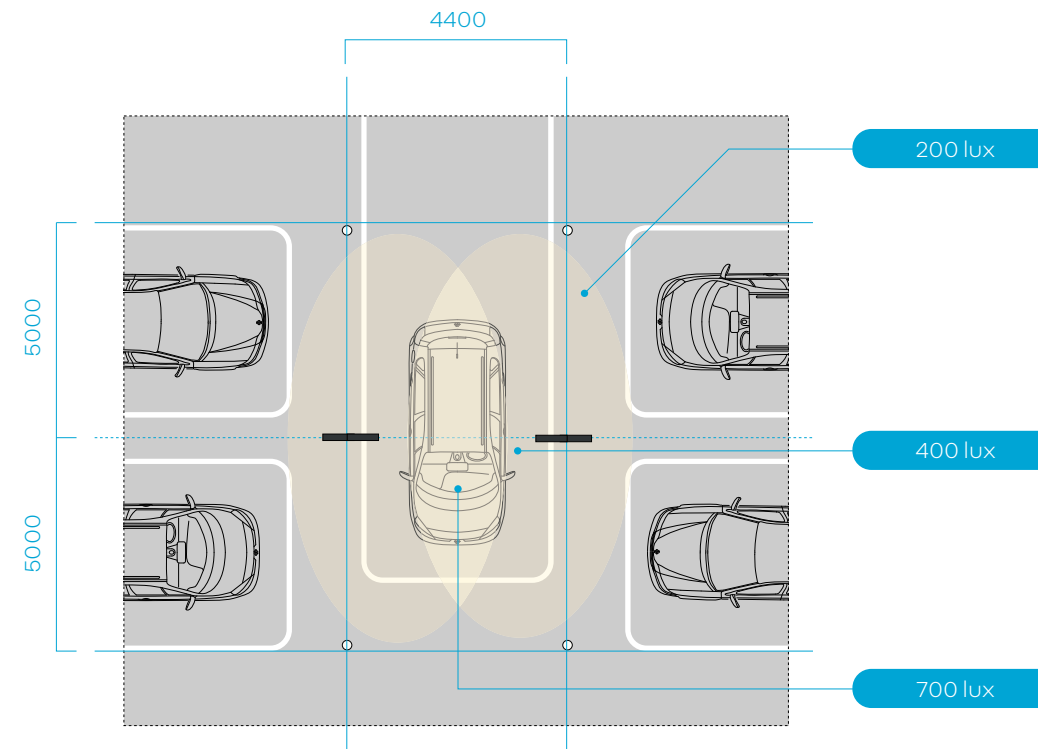

ILLUMINANCE LEVELS



EXAMPLE OF SPOTLIGHT: YAKI LARVIK SLIM 50 WATTS

4.29 exploded view of lighting mast

key

- 1 75X50mm mild steel uprights with 50mm square section spacers with welded to a base plate. Frame to be shot blasted & zinc treated. Foundation pad via M16 resin anchors.
- 2 Top cover plate of 2mm aluminium pre lacquered to match RAL 7021 dark grey. Uprights.
- 3 Pre lacquered aluminium RAL 7021 dark grey, cladding panels fasten to frame via M5 machine screws.
- 4 Pre lacquered aluminium RAL 7021 dark grey.
- 5 240X500 mm pre lacquered aluminium lighting shroud RAL 7021 dark grey with a galvanised top 'U' shaped bracket for holding the Yaki Larvik Slim lighting unit
- 6 Pre lacquered aluminium bottom cover RAL 7021 dark grey
- 7 240X700 pre lacquered aluminium lighting shroud RAL 7021 dark grey with a galvanised top 'U' shaped bracket for fixing back to the mild steel. Upright.

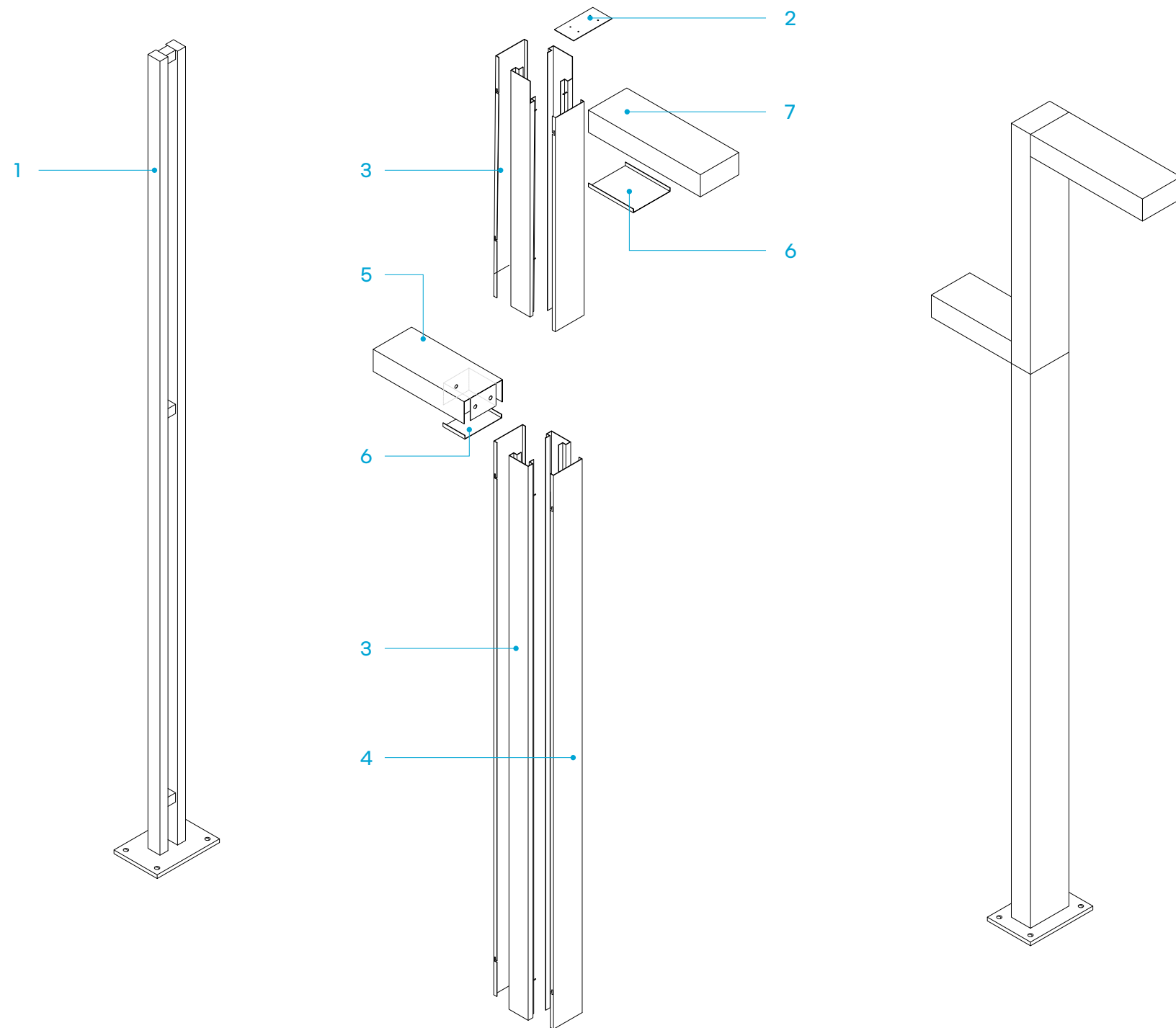

4.30 identification of sales area

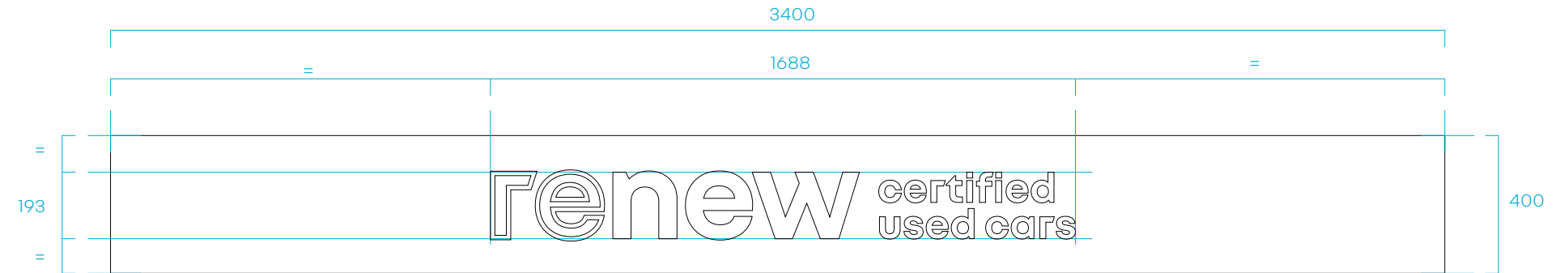

principle

The renew signature identifies the sales area for used vehicle sales.

This signature, which is already present on the entrance arch, appears again on the sales area frontage in line with the façade where the entrance door is located.

It is always in white (adhesive or illuminated) letters applied to a dark grey background.

- 1 renew signature centred on the frontage in adhesive white on a RAL 7021 dark grey background with a 40% gloss finish
- 2 Promotional sign

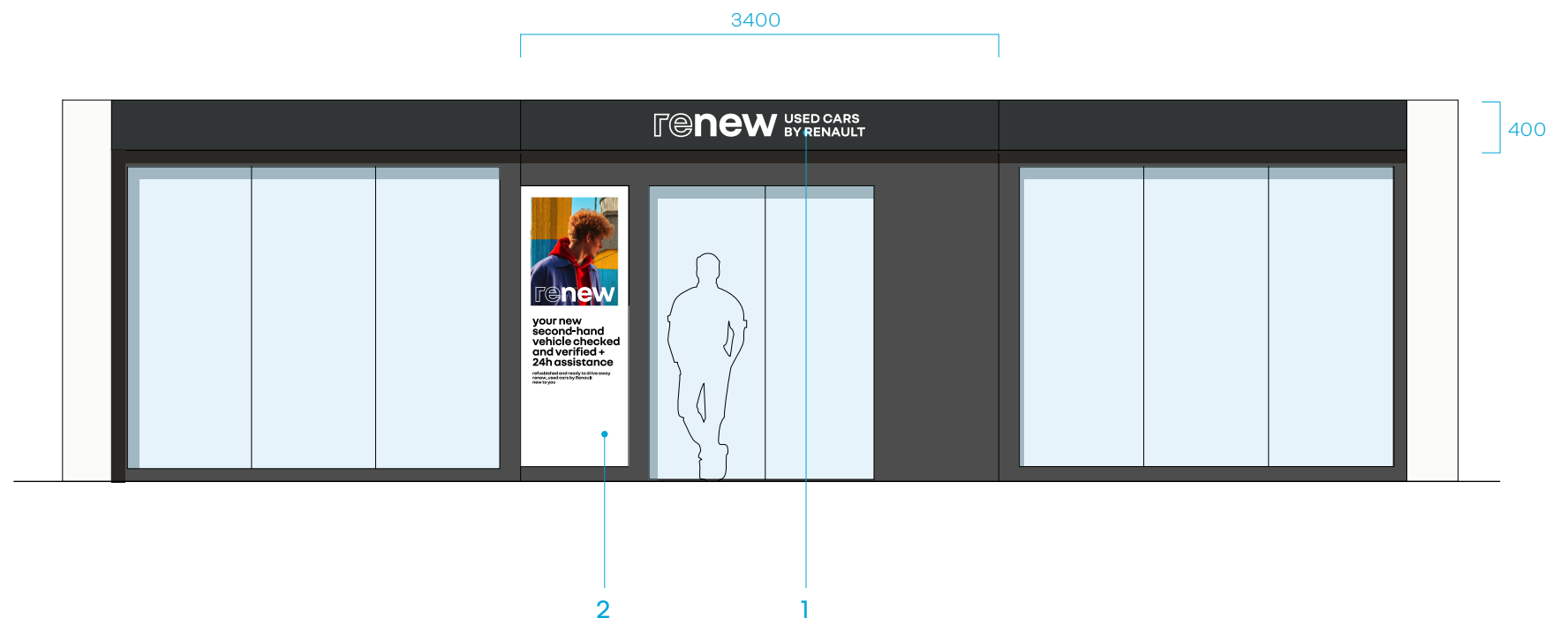

4.31 2m² promotional banner



principle

The 2m² banner is held by 2 posts anchored to the ground by a concrete block.

A banner made of 450 g/m² PVC, incorporating 2 sewn vertical cords, is stretched taut between the 2 posts. It may be recto-verso printed if necessary.

The posts incorporate the tensioning system which can be accessed from the side. The banner is changed by removing the upper cover.

4.32 details of 2m² promotional banner

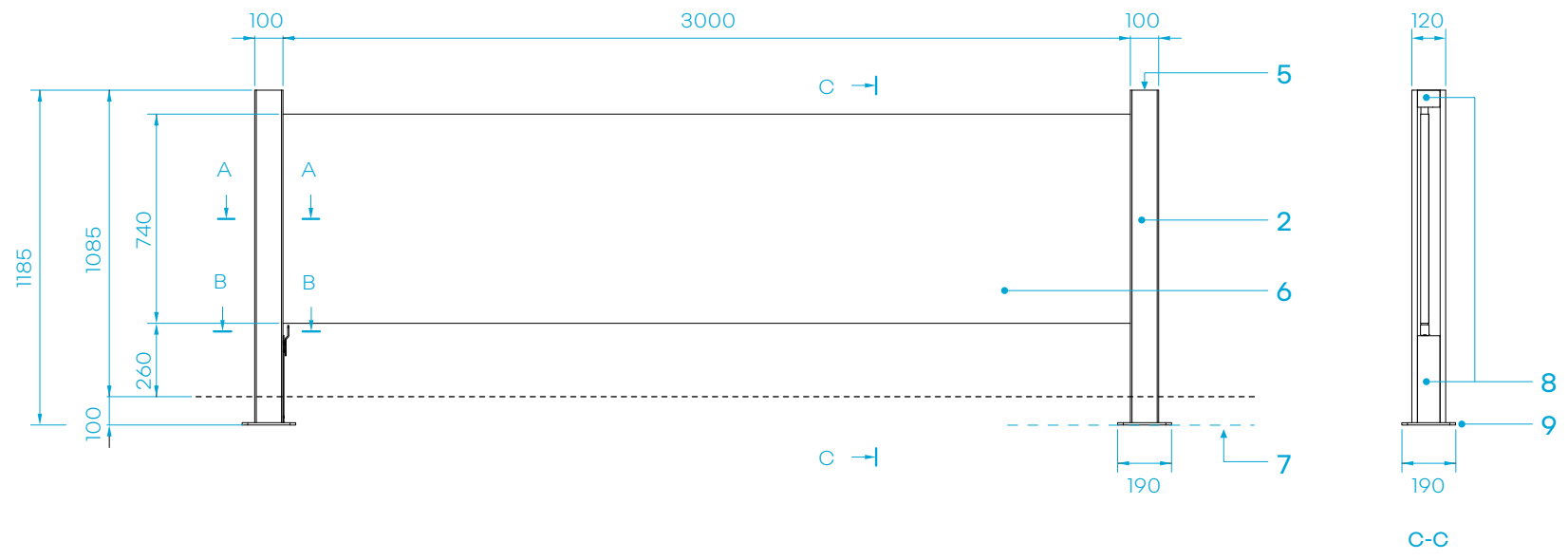

key

- 1 Banner attachment system
- 2 Pole in aluminum painted gray RAL 7021
- 3 Tension system with retractor
- 4 Cover made of aluminum sheet, ep. 2 mm, lacquered gray RAL 7021
- 5 Crank
- 6 Banner
- 7 Ground level - 10 cm
- 8 Aluminium inner cover lacquered RAL 7021 gray
- 9 Aluminum platinum

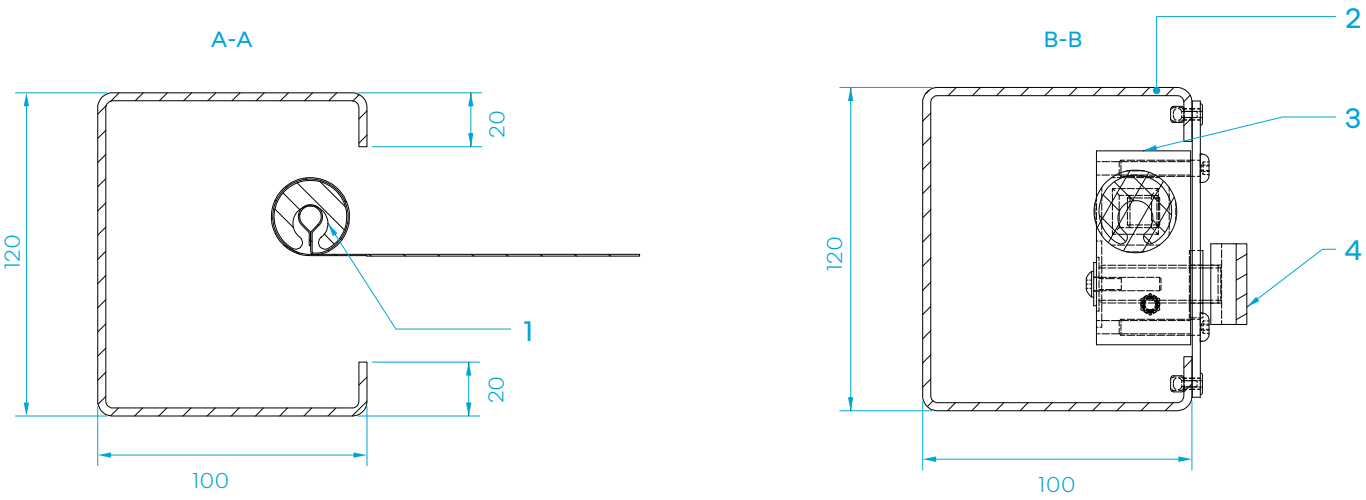

Note.

The described system is a standard product marketed by the Pommier company.

www.pommier.eu

An equivalent system can be used or developed by the signmaker.

4.33 ground markings

description

The purpose of the ground markings is to structure the renew outdoor display by positioning the vehicles precisely in the appropriate spaces.

The markings on the ground of the central bay emphasize its main axis.

The ground markings are made with epoxy paint after outlines have been drawn on the ground.

The markings on the ground of the central bay are always present, whether or not there is a canopy.

- 1 Markings on the ground of the central bay in RAL 9003 white epoxy
- 2 Markings on the ground of the parking areas in RAL 9003 white epoxy (in diagonal or perpendicular layout depending on the configuration of the site)
- 3 Markings on the ground of priority display areas in RAL 9003 white epoxy

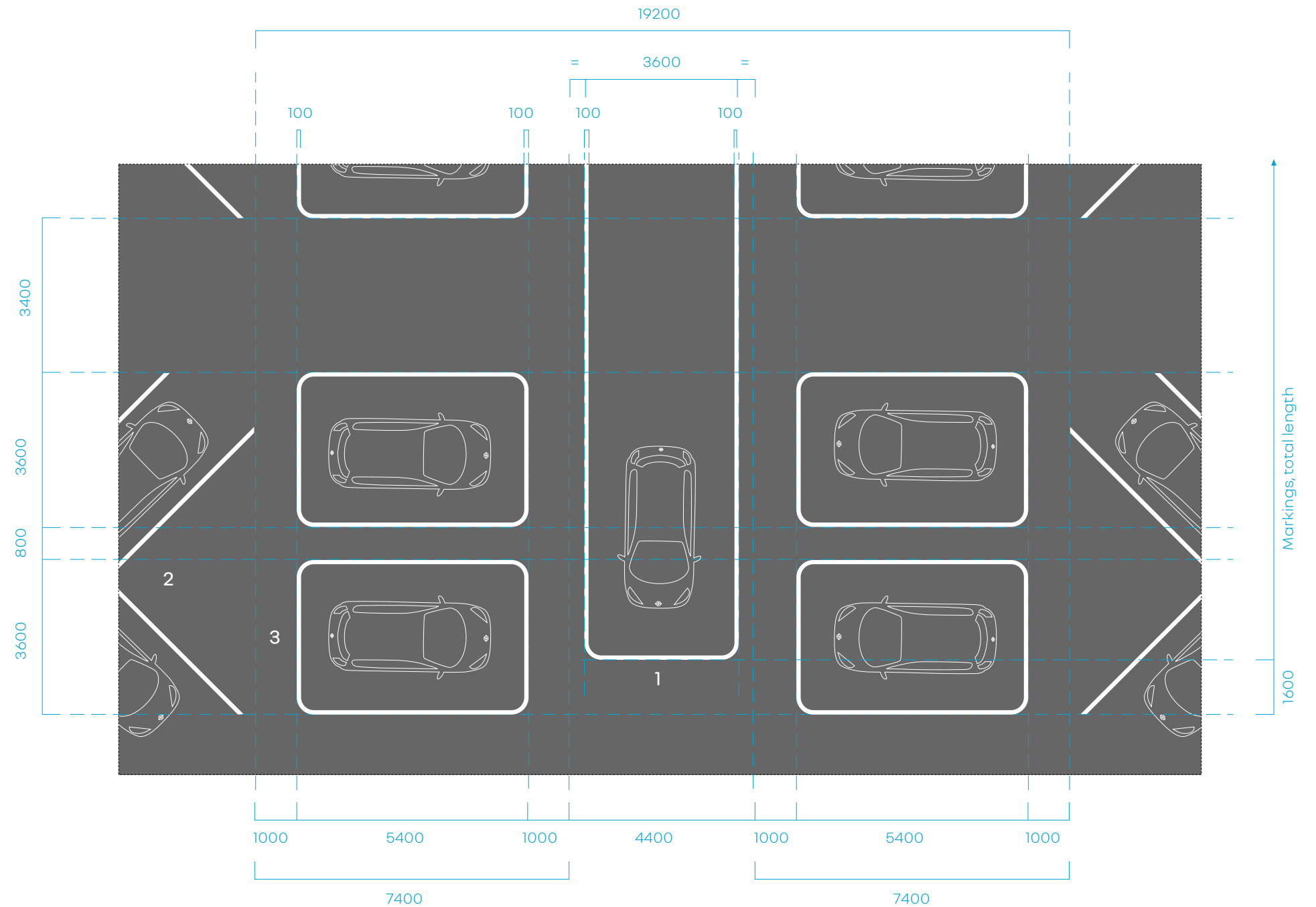

4.34 outlines of ground markings

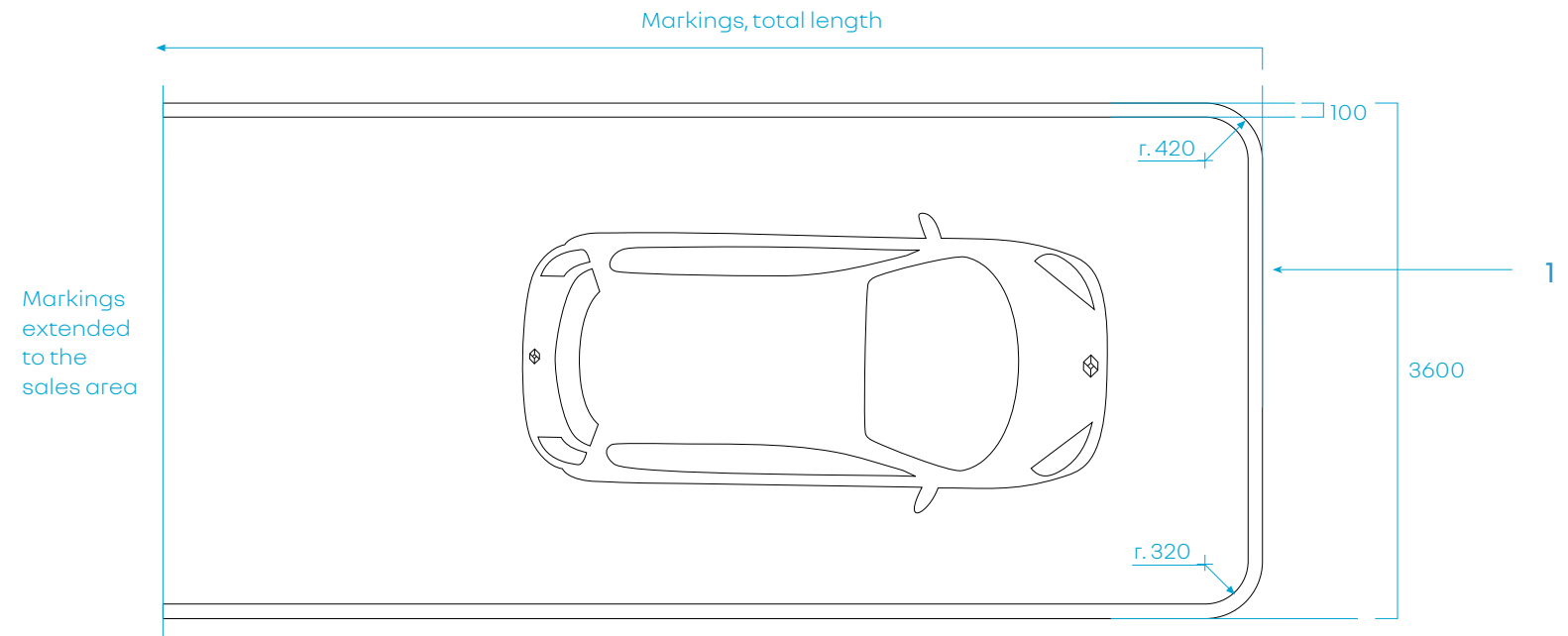
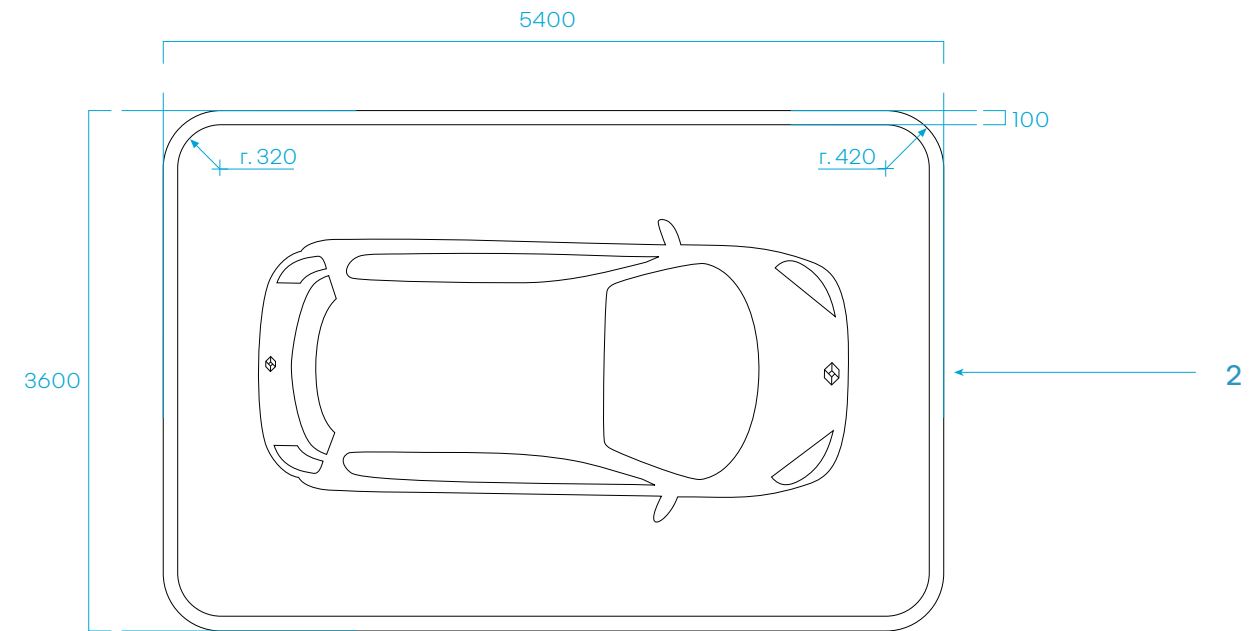

key

- 1 Markings on the ground of the central bay in RAL 9003 white epoxy
- 2 Markings on the ground of priority display areas in RAL 9003 white epoxy

4.35 parking space markings

principle

Parking areas can be organized either in a diagonal or perpendicular layout depending on the configuration of each site.

The ground markings for the parking spaces are made with epoxy paint after outlines have been drawn on the ground.

- 1 Markings on the ground of the central bay in RAL 9003 white epoxy
- 2 Markings on the ground of priority display areas in RAL 9003 white epoxy
- 3 Markings on the ground of the parking areas in RAL 9003 white epoxy (in diagonal or perpendicular layout depending on the configuration of the site)

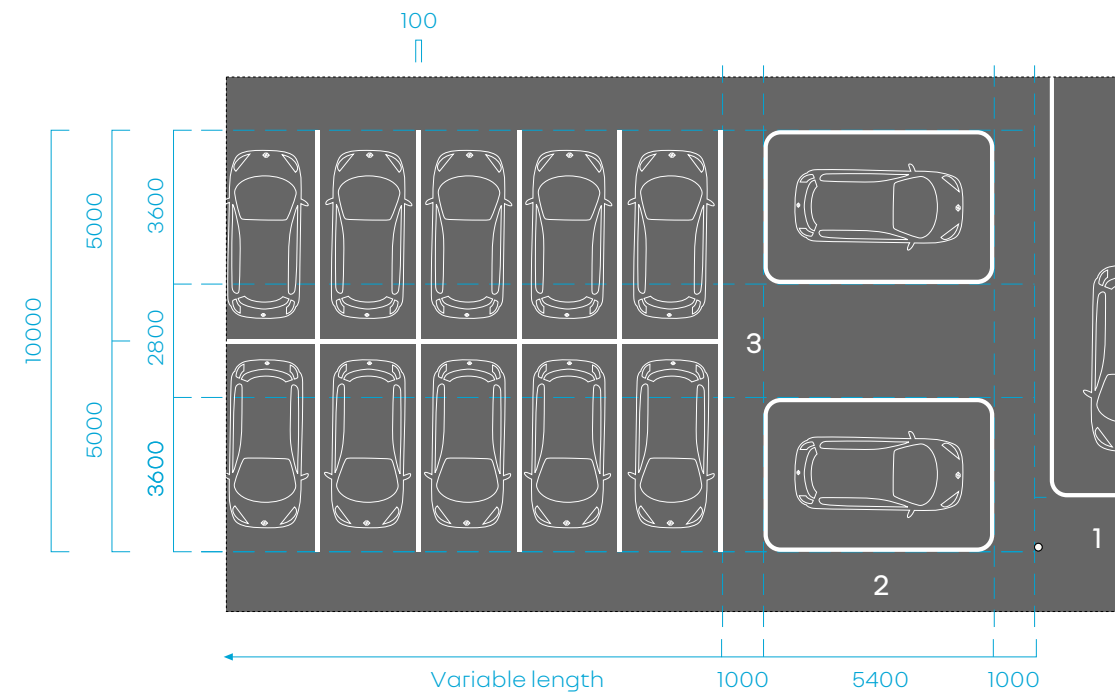
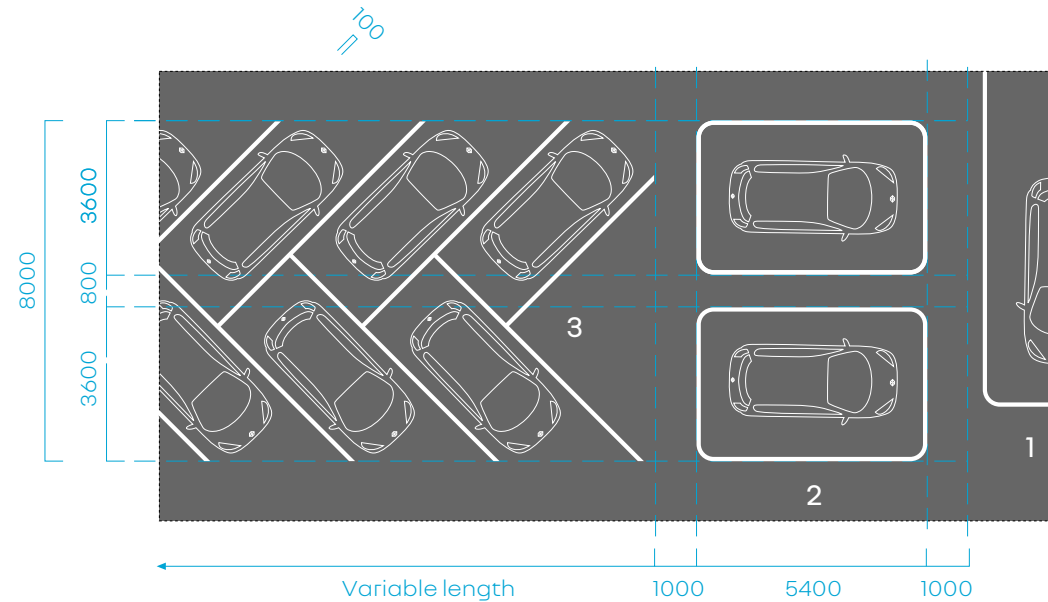

5

**technical principles
for renew showrooms**

5.1 facade

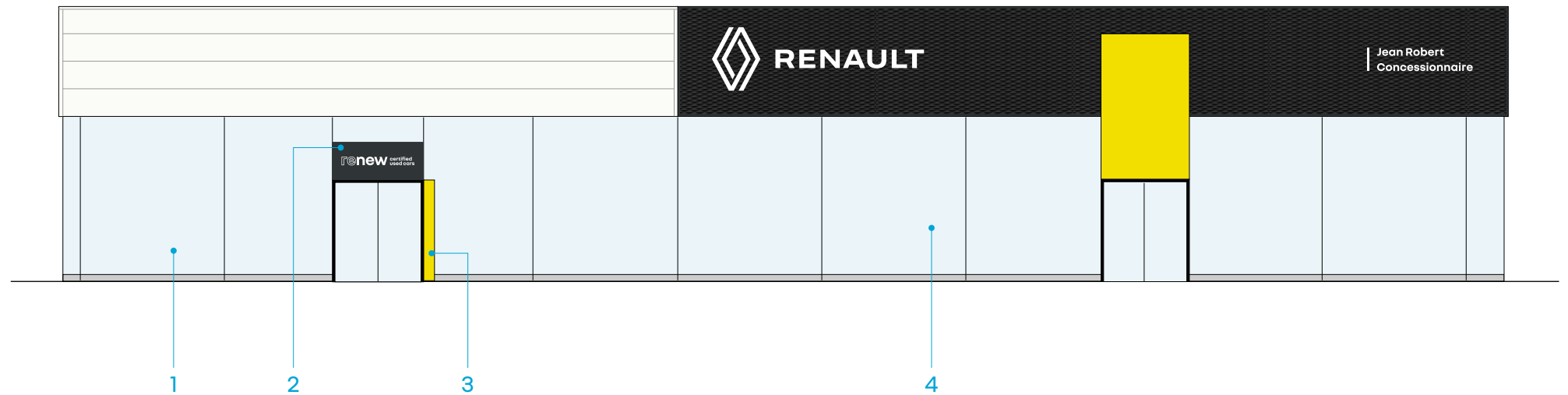

Identification principle

The façades of renew showrooms are identified by:

- the renew signature on a dark grey background placed above the main entrance door to the showroom,
- the vertical entrance door markings.

- 1 renew showroom
- 2 renew signature in white lettering on a dark grey background
- 3 Vertical entrance door markings
- 4 NV showroom

5.2 door entrance signage



key

- 1 Illuminated signage
- 2 Adhesive markings
- 3 Horizontal strips
- 4 Vertical entrance marker sign

5.3 front panel of box over entrance

principle

A light box is located above the main entrance door to renew showrooms.

A renew complete signature is centred on the face made of white PMMA.

- 1 renew signature on 2 lines in white type,
- 2 RAL 7021 dark grey satin finish background in aluminium sheeting.

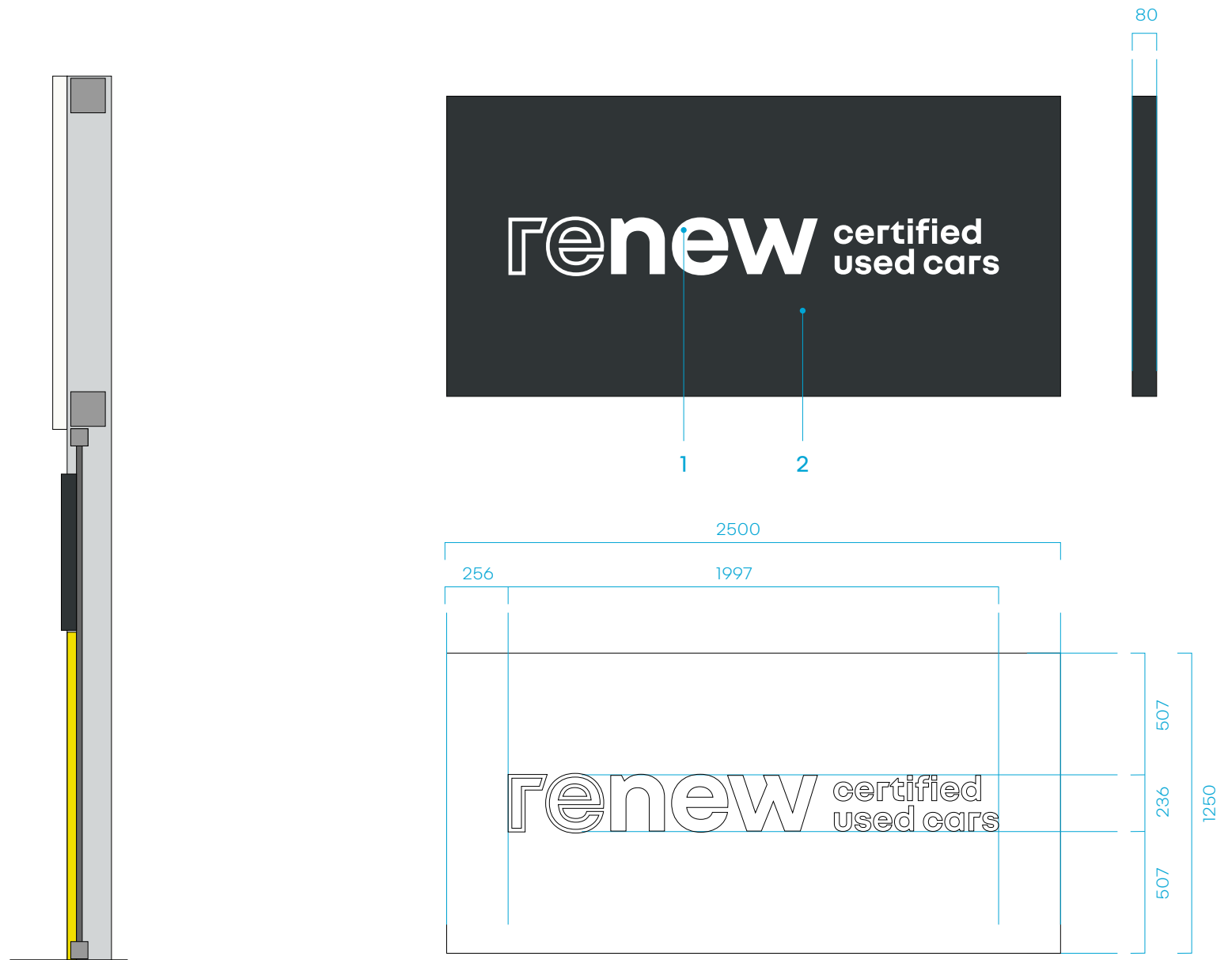

5.4 lighting of box over entrance

description

The face is lit with chain LEDs.

The converter is mounted inside the box.

Performance characteristics

Chain LED with minimum IP65 protection rating.

Temperature: 6,500° K Cool White.

Mean luminance: 3000 cd/m² with a maximum of 350 cd/m².

The warranty for all LED lighting systems and parts is 5 years, subject to compliance with conditions of use and maintenance.

Light output reduced by 50% after 50,000 hours operation.

Minimum guaranteed lifetime: 50,000 hours.

Supply: 220 volts

12 volt converter with regulated voltage, IP 68 protection.

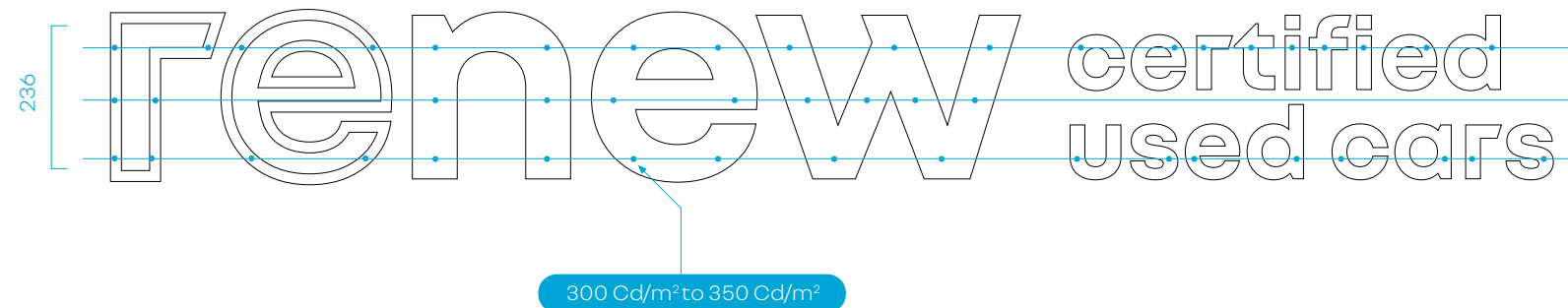

The dots are a schematic representation of the measurement points that should present similar light intensity values in order to obtain even lighting across each of letters.

The readings, performed with a calibrated luminance meter, should ideally be performed without light interference and at a distance of between 1 and 2 m from the letter face.

5.5 installation of lighting of box over entrance

principle

This recommendation is made on the basis of a 20 lumens module with a luminous efficacy of 90 to 100 lumens/watts.

The instruction remains indicative and shall require a validation and a test for compliance with the performance targets indicated in this document.

The LEDs are installed perpendicular to the face. Spacing of the LEDs shall be adjusted to achieve a regular luminous flow on the PMMA face.

description

- Temperature: 6,500° K Cool White.
- Module power rating: 20 lumens
- Luminous efficacy: 90-100 lm/watt
- Converter, 12 volts, constant current
- Number of modules: 90
- Approx. power consumption : 22 watts

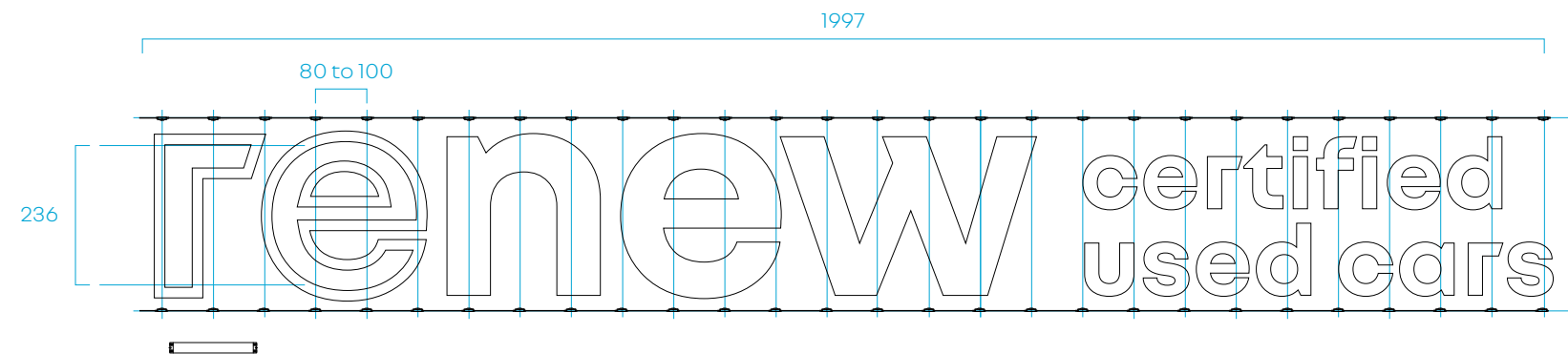

5.6 exploded view of lighting of box over entrance

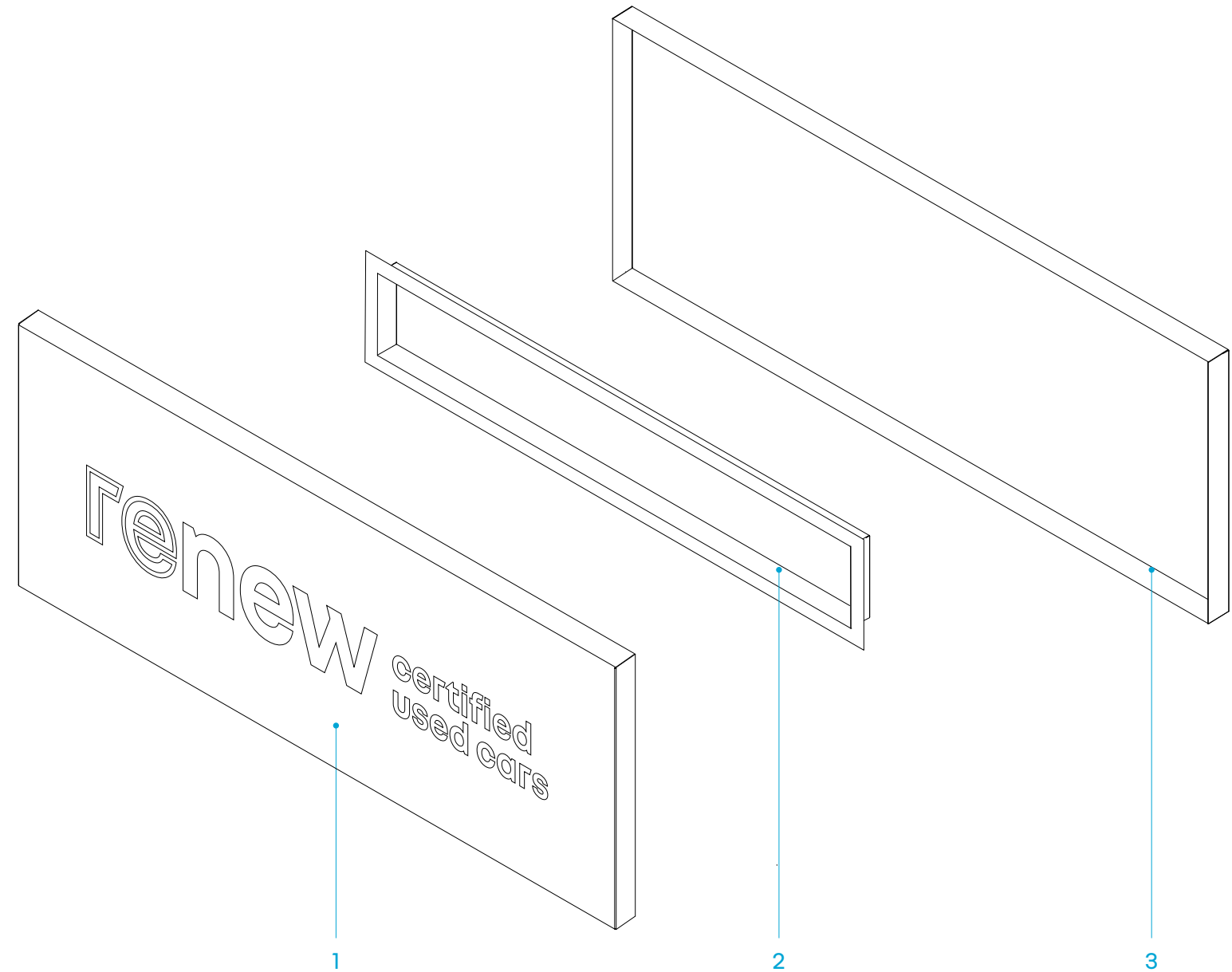

key

- 1 Front panel in pre-lacquered RAL 7021 dark grey aluminium sheeting with 40% gloss with renew signature in white diffusing PMMA glued at the back of the face.
- 2 Reflector in aluminium with chain Leds and converter
- 3 Back of the sign in natural aluminium sheeting.

5.7 retrofit of lighting of box over entrance

principle

It is recommended to retrofit the existing box signs.

For this, it will be necessary to remove the the complete front face and to replace it on site with new face (including the lighting material).

- 1 Front panel in pre-lacquered RAL 7021 dark grey aluminium sheeting with 40% gloss with renew signature in white diffusing PMMA glued at the back of the face.
- 2 Reflector in aluminium with chain Leds and converter.

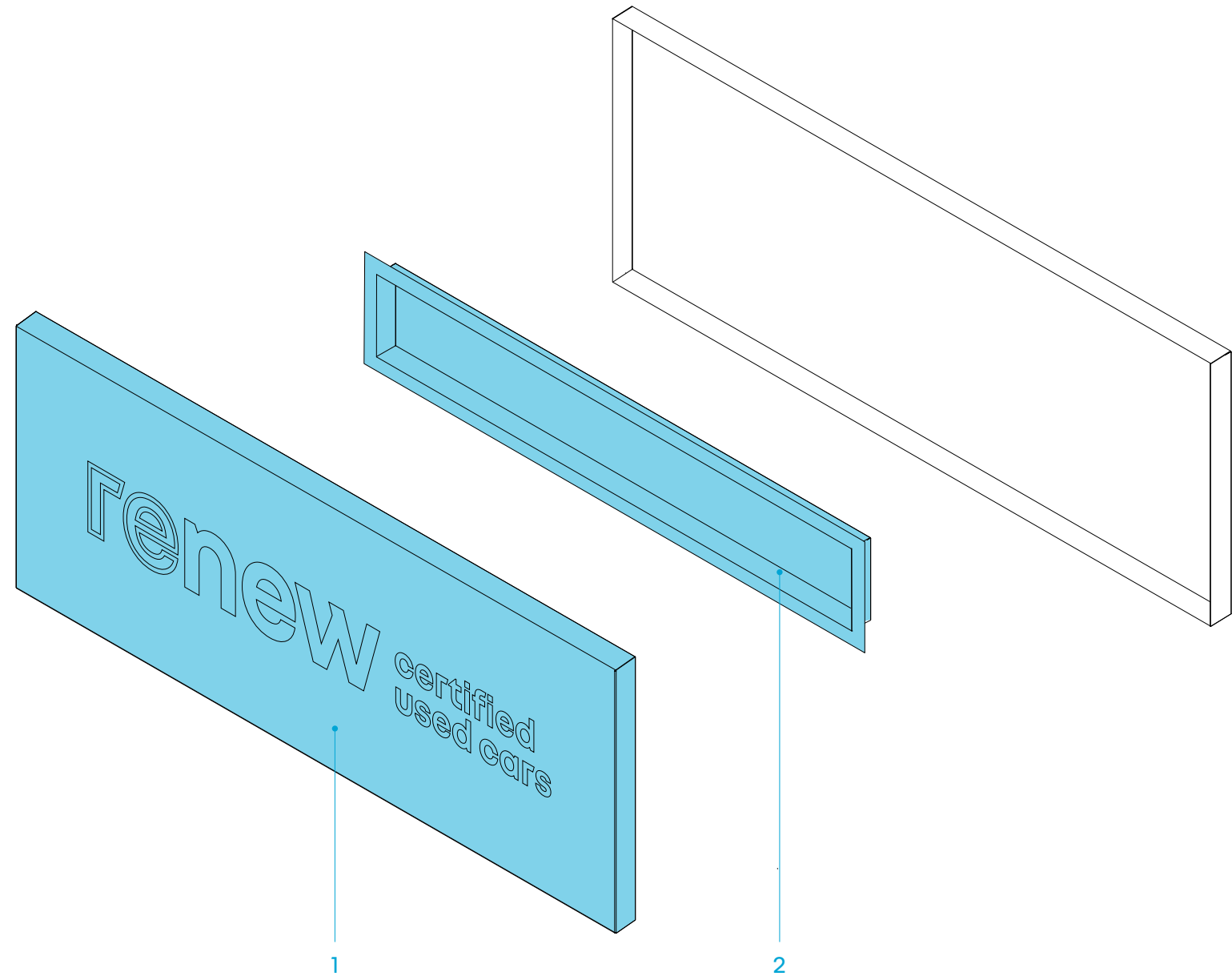

5.8 adhesive markings on entrance door



key

- 1 "bienvenue" wording in nouvel'R Bold typography, centred, matt white adhesive,
- 2 renew signature, left-aligned, matt white adhesive
- 3 Opening hours in nouvel'R Regular and nouvel'R Bold typography, left-aligned, matt white adhesive

5.9 interior identification box

principle

When the renew showroom is integrated into a Renault Store showroom, a suspended light box is installed at the perimeter of the section set aside for the display of used vehicles.

The box is positioned at a height of 4 m from the ground.

It is double-sided:

- on the front side, it features the renew signature,
- on the reverse side, it features the words "new vehicle showroom".

Dimensions: L. 3000 x H. 450 x Thk. 80 mm.

description

The box is made up of 2 panels in pre-lacquered RAL 7021 grey aluminium sheeting with 40% gloss satin finish, with raised edges and internal cutaways, fixed to an aluminium frame.

The panels are backlit, with the lettering in light-diffusing white PMMA pasted on the back of the each panel.



5.10 outlines of interior identification box



Front face

1

2



Reverse face

3

2

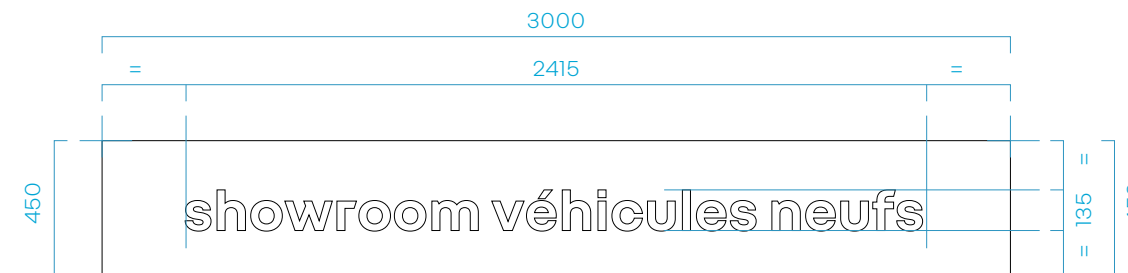
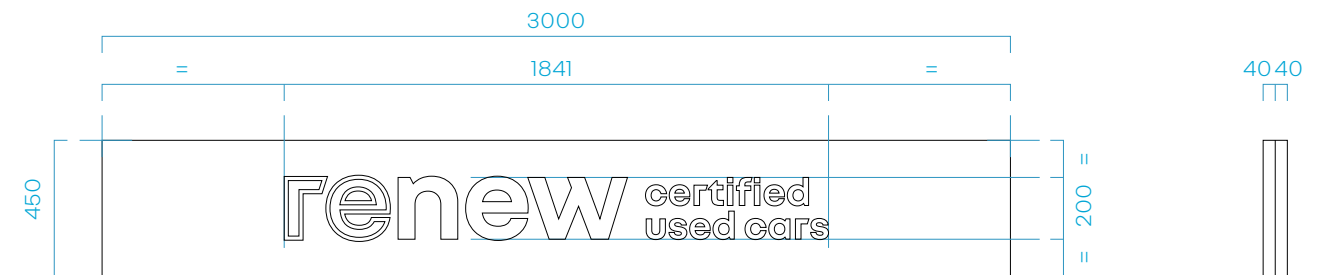

key

- 1 renew signature in white
- 2 RAL 7021 dark grey satin finish background
- 3 Words "new vehicle showroom" in reverse white type, nouvel'R bold typography, lower case on all letters, centre-aligned.

5.11 lighting of interior identification box

description

Illumination of the front and rear by chain LEDs mounted perpendicular to the panels.

The converter is mounted inside the box.

performance characteristics

Chain LED with minimum IP65 protection rating.

Temperature: 6,500° K Cool White.

Mean luminance: 250 cd/m² with a maximum of 300 cd/m².

The warranty for all LED lighting systems and parts is 5 years, subject to compliance with conditions of use and maintenance.

Light output reduced by 50% after 50,000 hours operation.

Minimum guaranteed lifetime: 50,000 hours.

Supply: 220 volts

12 volt converter with regulated voltage, IP 68 protection.

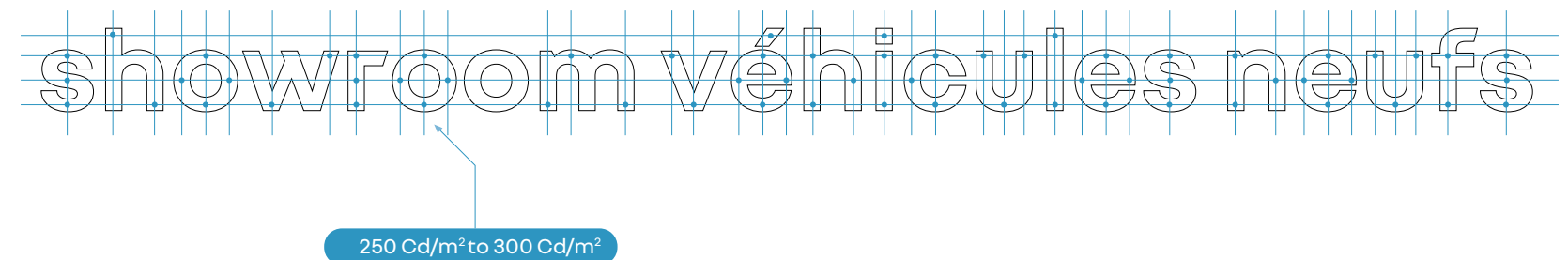
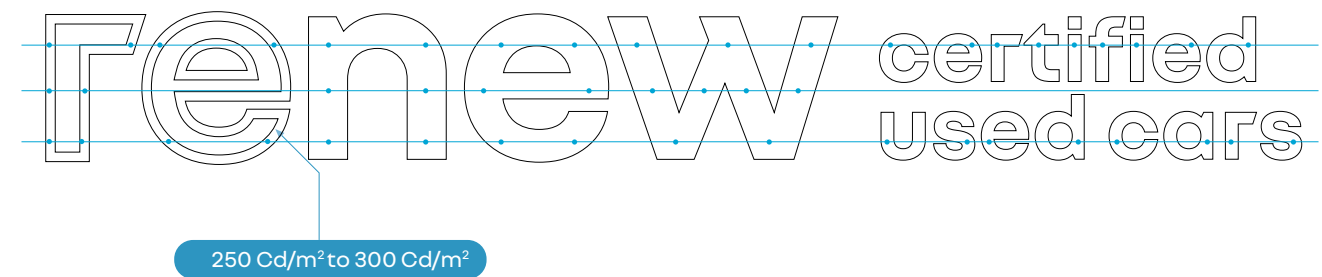

The dots are a schematic representation of the measurement points that should present similar light intensity values in order to obtain even lighting across each of the letters of the word Renault.

The readings, performed with a calibrated luminance meter, should ideally be performed without light interference and at a distance of between 1 and 2 m from the letter face.

5.12 lighting of interior identification box

principle

This recommendation is made on the basis of a 20 lumens module with a luminous efficacy of 90 to 100 lumens/watts.

The instruction remains indicative and shall require a validation and a test for compliance with the performance targets indicated in this document.

The LEDs are installed perpendicular to the panels and illuminate the front and rear panels.

description

- Temperature: 6,500° K Cool White.
- Module power rating: 20 lumens
- Luminous efficacy: 90-100 lm/watt
- Converter, 12 volts, constant current
- Number of modules: 50
- Approx. power consumption: 10 watts

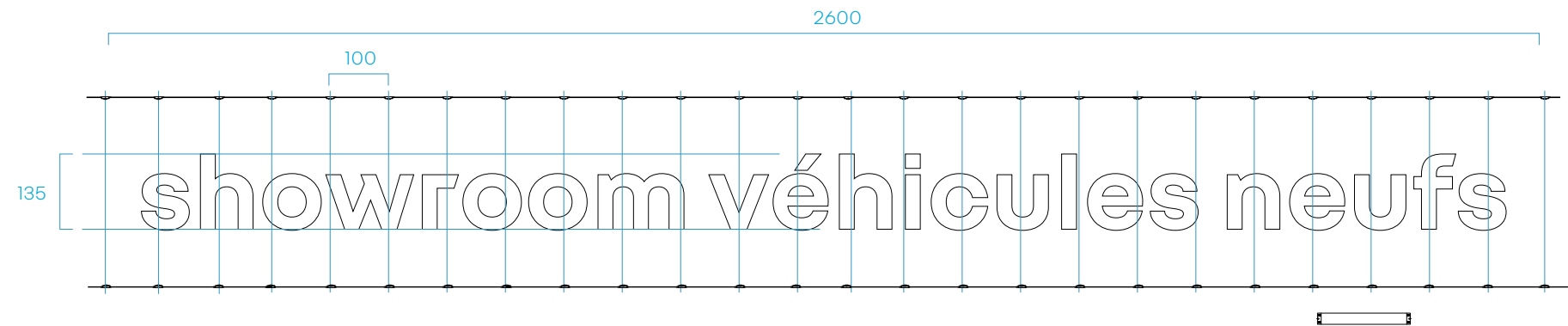
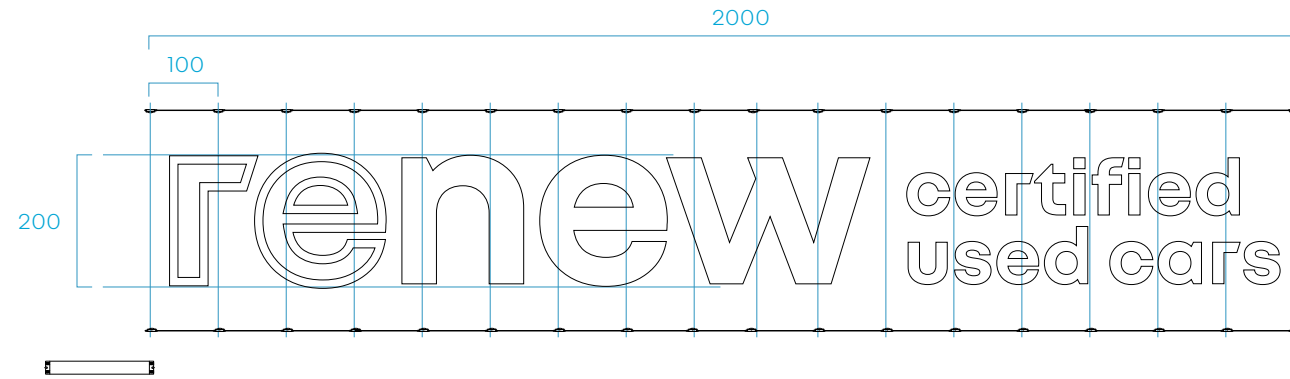

6

**technical principles
for small renew display area**

6.1 presentation of the area

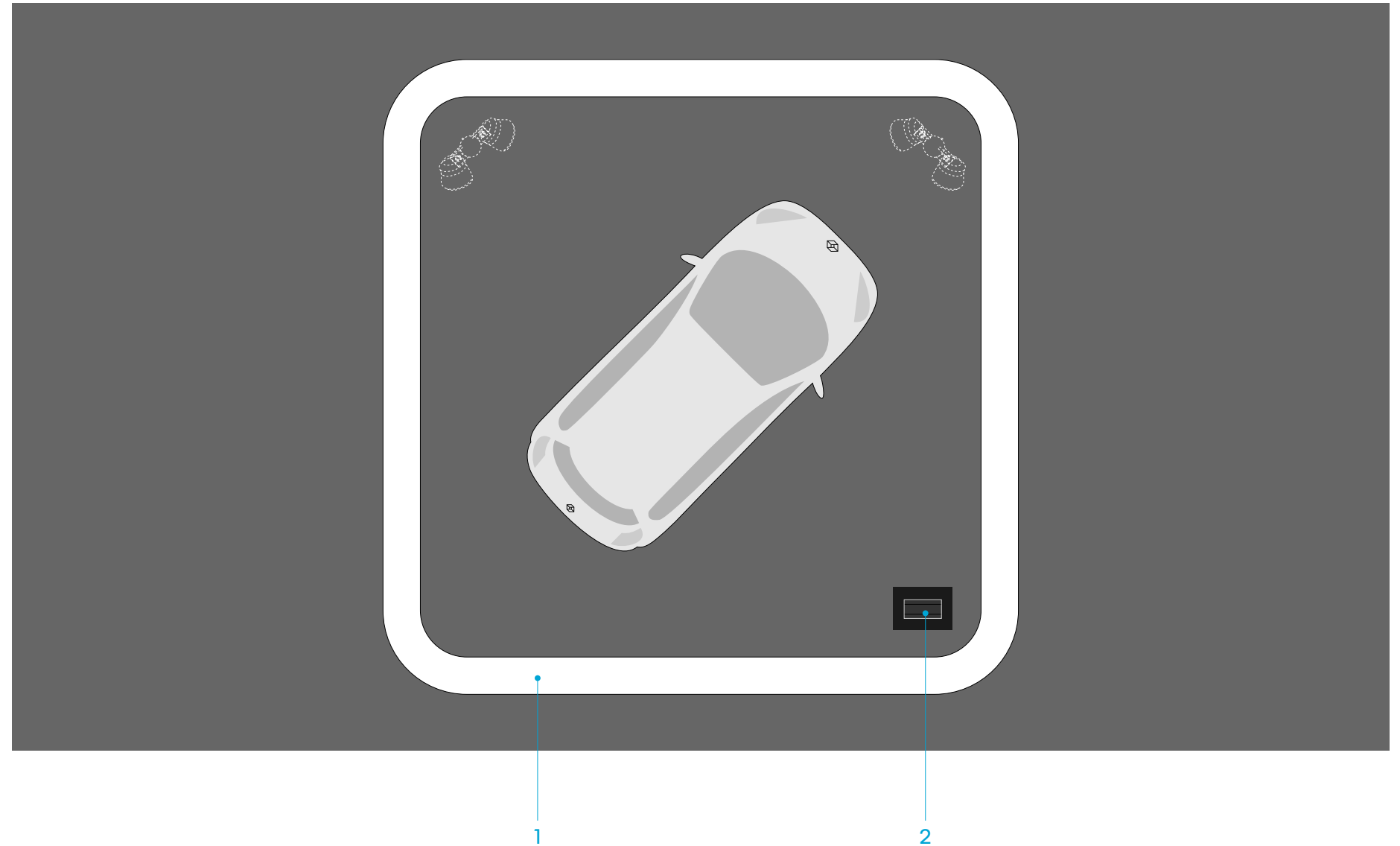

principle

A small display area dedicated can be implemented in front of the showroom among other areas (Actu, Test Drive or E-Tech areas...).

It uses the same items as other areas.

- 1 Ground markings
- 2 Area mast

6.2 general view of area mast

description

The area masts are made up of two aluminium half-panels with raised edges mounted on an aluminium frame.

The edges are closed off by a sheet with raised edges that clicks into the structure (invisible fastenings)

The masts are anchored to concrete blocks with anchoring poles or chemical anchor bolts.

The finishing is completed by an attachment plate concealer.

key

- 1 Markings on the panel
- 2 Panel in pre-lacquered aluminium sheeting (one piece), RAL 7021 dark grey
- 3 Attachment plate concealer RAL 7021 dark grey pre-lacquered aluminium sheeting, 15/10 mm thick
- 4 Pre-lacquered aluminium sheet edges (one piece), RAL 7021 dark grey

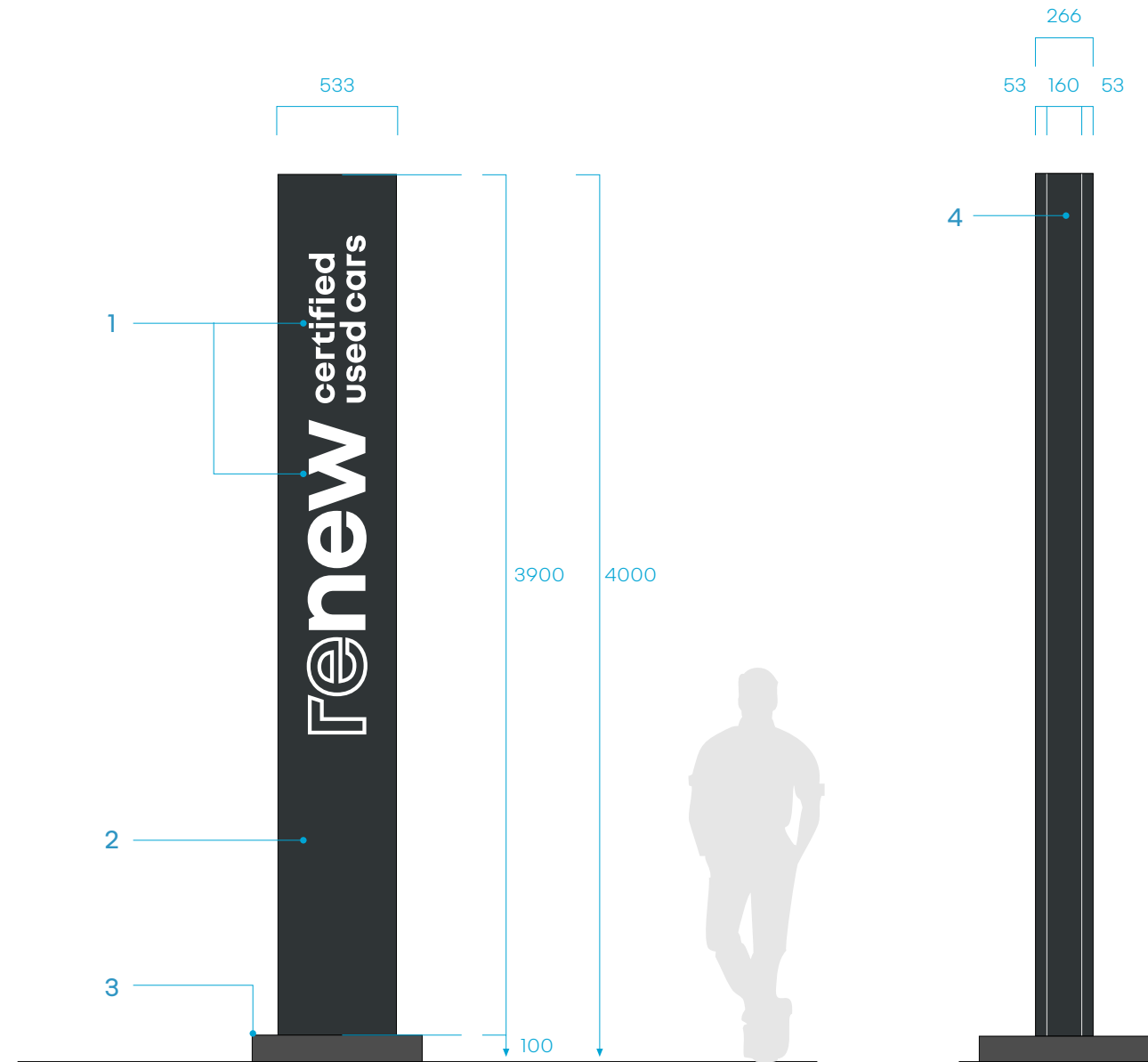

6.3 lighting of area mast

principle

Area masts can be illuminated or non-illuminated as required:

Only the front side of the illuminated area masts is illuminated. The lettering is in white, light-diffusing PMMA.

The trim is to be done in marquetry (PMMA flush to the surface) for the word renew.

For the small letters of the words above, the white PMMA sheet is glued on the back of the aluminum face.

Non-illuminated back panel receives an adhesive decoration.

key

- 1 Day view
- 2 Night view

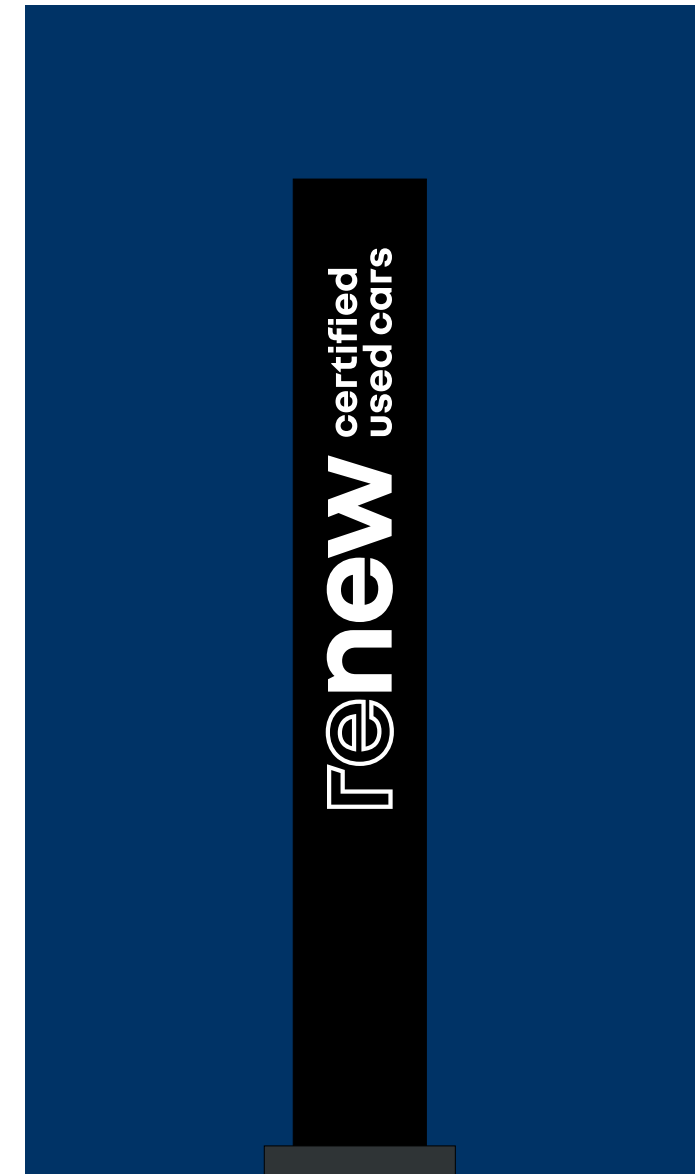
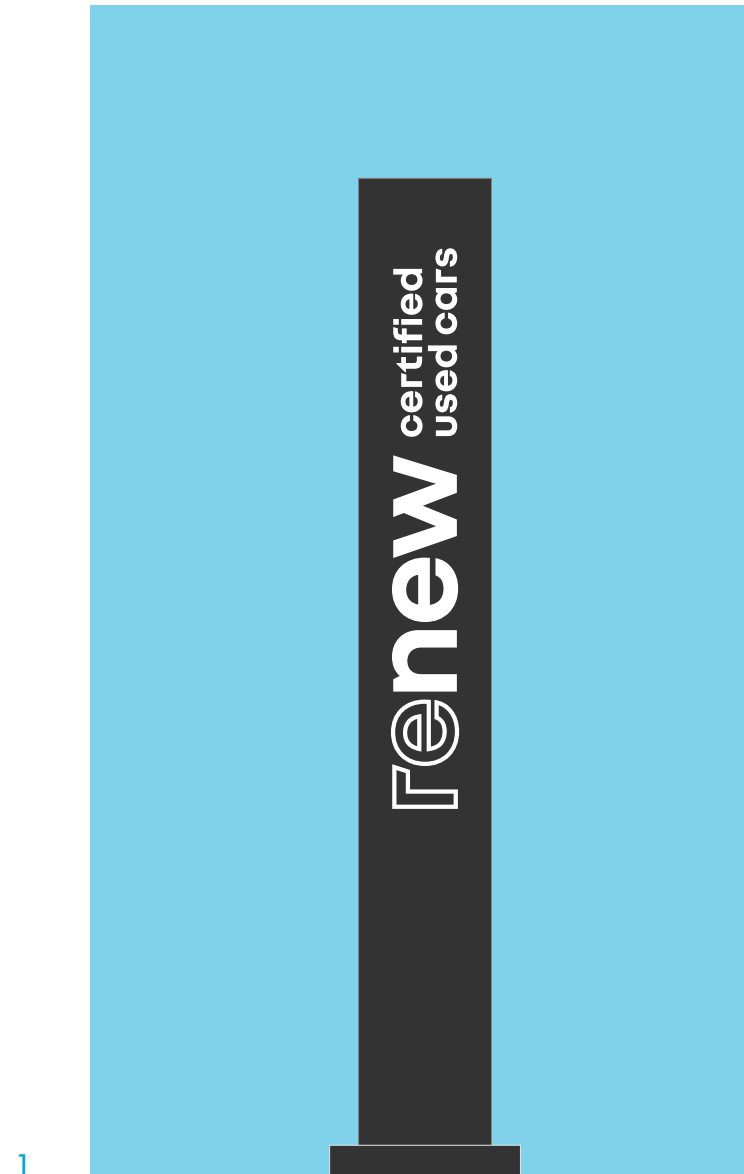

6.4 outlines of faces of area mast

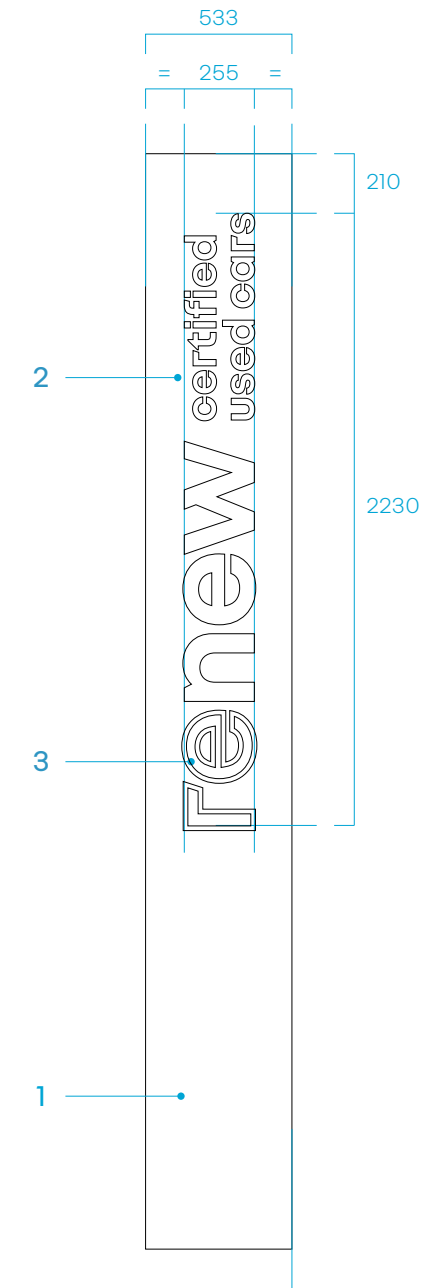

key

- 1 Panel in aluminium sheeting (one piece), pre-lacquered RAL 7021 dark grey
- 2 Lettering in White, 40%-light diffusing PMMA or white adhesive, nouvel'R Bold Typeface, bottom-aligned
- 3 Lettering in White, 40%-light diffusing PMMA or white adhesive.

6.5 anchoring of area mast

ground attachment system

The sign is anchored to the ground via one plate fitted with 4 x M16 anchors. The attachment plate has a hole drilled at its centre for the routing of the underground power supply.

The assembly is covered with an attachment plate concealer allowing access to fastenings in order to facilitate replacement in case of damage.

key

- 1 Aluminium plate
- 2 Drilled hole for power supply routing
- 3 Central aluminium structure
- 4 Aluminium attachment plate concealer
- 5 Steel anchor M16

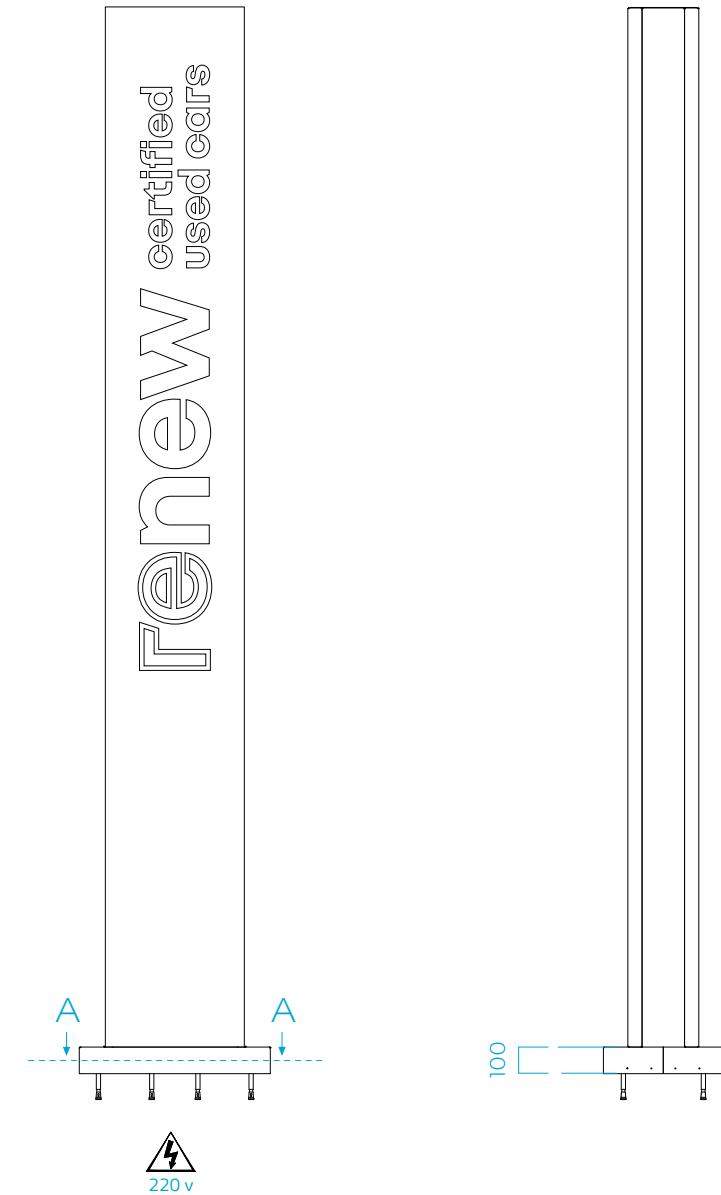
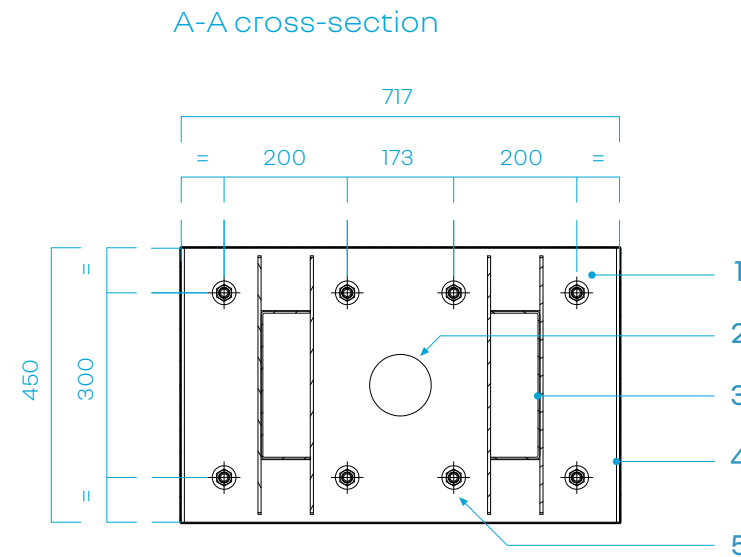

6.6 exploded view

key

- 1 Aluminium cover, same colour as front and rear, RAL 7021 dark grey
- 2 Pre-lacquered aluminium sheet edge, RAL 7021 dark grey
- 3 Unfinished aluminium sheet structure
- 4 Pre-lacquered aluminium sheet front panel with raised edges comprising internal cutaways to avoid light leakage
- 5 Adhesive marking of the back panel
- 6 Lettering in white PMMA
- 7 Rear panel identical to front panel with adhesive markings
- 8 Attachment plate concealer in RAL 7021 grey pre-lacquered aluminium sheet, comprising 2 half-cowlings secured laterally with stainless steel fixing elements
- 9 Unfinished aluminium plate with lateral pleats welded to upright structure and gusset plates
- 10 Chain LED and converter

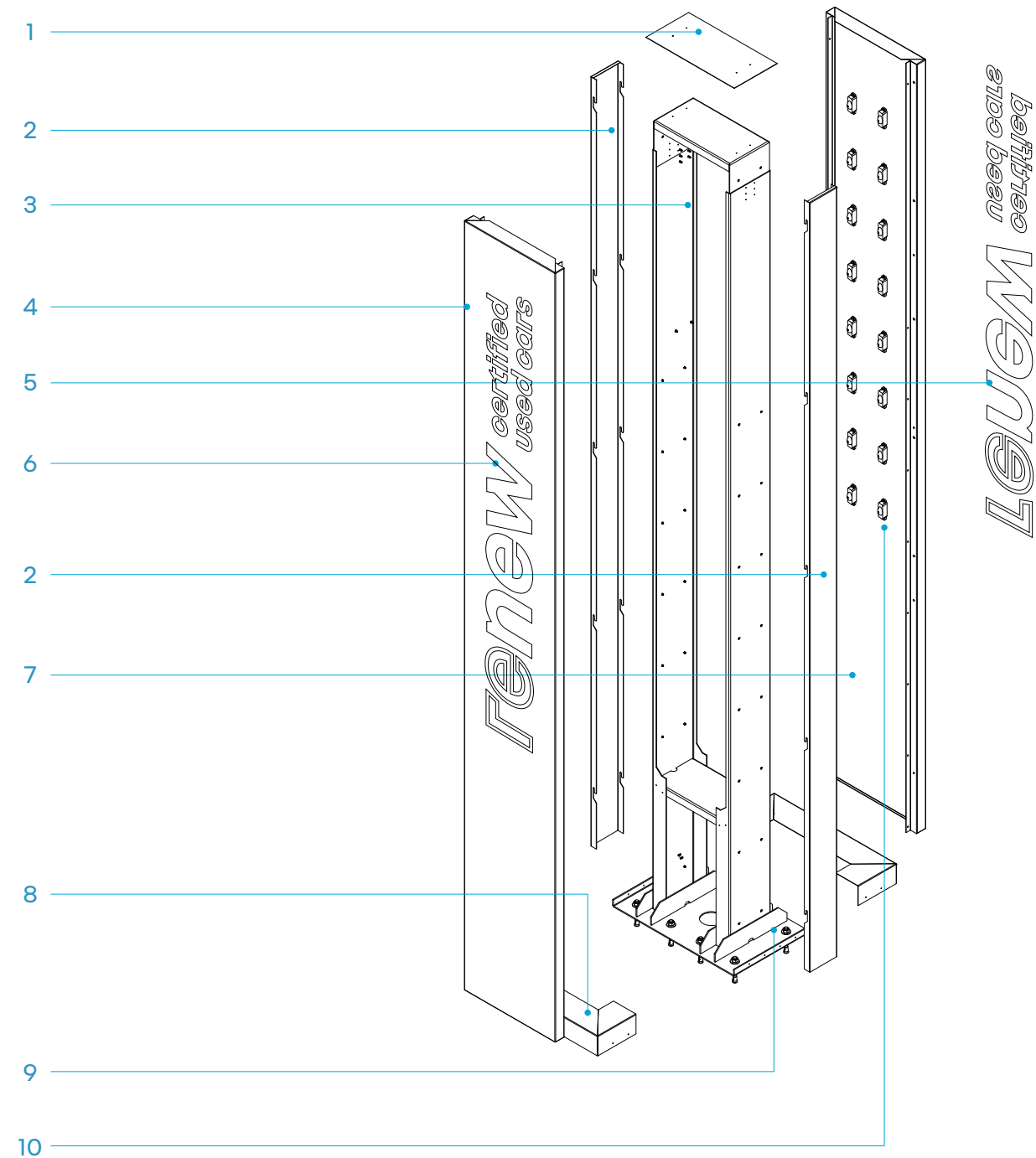

technical principles for small renew display area

6.7 lighting performances

description

Illumination of the front and rear by chain LEDs mounted perpendicular to the panels.

The converter is attached to structure so as to be easily accessible.

performances

Chain LED with minimum IP65 protection.

Temperature: 6,500° K Cool White.

Mean luminance: 350 cd/m² for white sections.

The warranty for all LED lighting systems and parts is 5 years, subject to compliance with conditions of use and maintenance.

Light output reduced by 50% after 50,000 hours operation.

Minimum guaranteed lifetime: 50,000 hours

Approximate power: 30 watts.

Supply: 220 volts

12 volt converter with regulated voltage, IP 68 protection.

key

- 1 PMMA in marquetry
2. PMMA glued behind the face

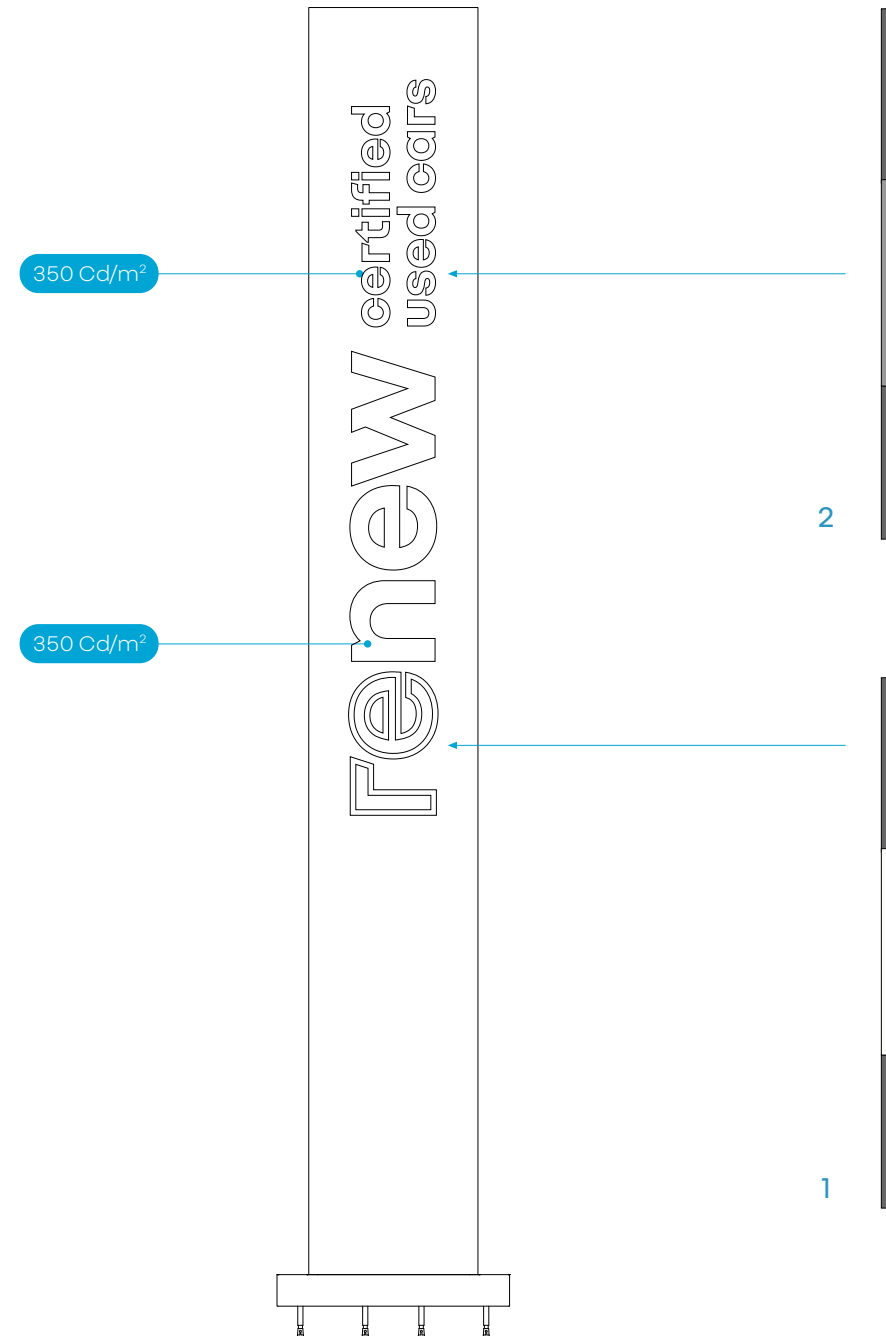

6.8 ground markings

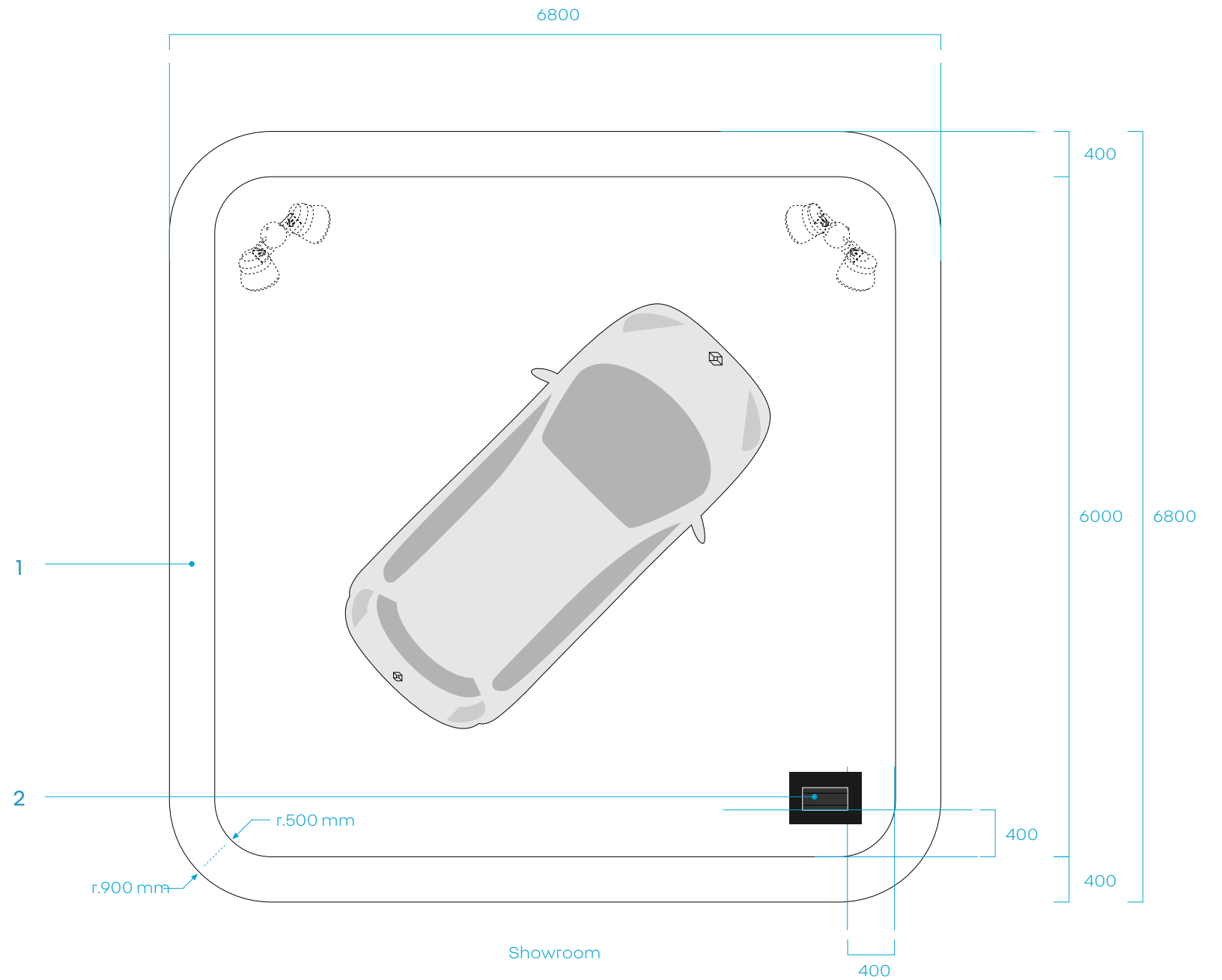

principles

- The area mast is located on the showroom side. The illuminated side is always facing the main road.
- Lighting of the area is optional.

key

- 1 RAL 9003 white matt epoxy ground marking
- 2 Area mast