



RENAULT
Passion for life

Renault Store - Technical specifications

Secondary network banners



Contents

General requirements

General technical requirements	4
--------------------------------	---

General remarks

General view	12
Colours and materials	13

Technical principles

Overview	15
Layout for 1,733 mm banner	16
Layout for 1,332 mm banner	18
Layout for 783 mm banner	19
Lighting for secondary network banners	23
Description of the woven mesh	24
Manufacturing	26

1

General technical requirements

General technical requirements

1.1 Preamble

RENAULT expects all those involved in the "Renault Store" programme to meet their obligations in terms of results as per the requirements of the Technical Specifications. The general rules and specificities set out below are to be considered as the minimum necessary that has to be done to achieve the expected result.

1.2. Safety of persons and property

The supplier shall be able to provide proof that it has analysed the risks related to the services it is to provide and that its personnel and any sub-contractors have undergone sufficient training. Strict compliance with legislation in terms of safety and protection of workers is required.

1.3. Respect for the environment

Materials and methods which make it possible to reduce harm to the environment shall be used wherever possible (recyclable materials, energy-saving technologies, toxicity of materials and products used, etc.).

The supplier shall be able to provide proof that it has the various administrative permits (operating permit, environmental permit) necessary to manufacture the various items of equipment and that it complies with the operating conditions required by the legislation in force or by the specific operating conditions in the countries concerned.

A global approach such as the ISO 14001 standard is recommended. e.

1.4. Quality

The supplier shall be able to provide proof that it works in accordance with ISO 9000 quality assurance standards, formal certification being particularly recommended in this regard. The signwriter shall attach a specific Quality Plan to its offer to assure RENAULT of its capacity to supply finished products and spare parts that are compliant with the contractual requirements, within the set time periods. It shall request its sub-contractors to do likewise.

The procedures applied must make it possible to:

- Be sure that the parts and products purchased, manufactured and supplied shall neither be used nor delivered before they have been checked and be recognized as compliant.
- Procedures shall be set out for identifying causes of non-compliance, which make it possible to provide sustainable solutions that can be applied more widely to resolve the non-compliance and prevent it reoccurring.

These operations shall be recorded in the appropriate documents and be approved by RENAULT prior to being applied more widely.

- Track changes in the quality of products and assembly and removal services using inspection and audit indicators (incidents, complaints, etc.).

This tracking shall result in preventive or corrective actions; they shall be approved by RENAULT before being applied.

General technical requirements

1.5. Compliance of messages and colours

Visuals must comply with the official images contained in this document.

All shades have a 40% satin finish unless specified otherwise. Particular attention should be paid to complying with the colour code.

Compliance with the tolerances for the L.a.b. is required.

2.1. General technical standards

The reference base to be followed for design and manufacturing shall, at the very least, be that required by Eurocode standards.

The regulations relating to the dimensioning of structures in force in each of the countries concerned shall be complied with taking climatic conditions into account.

The following obligations in terms of results must be met:

- Supported under their own weight, the equipment must appear perfectly horizontal and vertical.
- The parallel alignment of separate elements must be observed.
- Under normal wind conditions (Cf. NV65 and NF EN1991-1-4 (Eurocode 1)), the permissible bend between the fastening and the point most distant from the fastening (dimension "d") shall not exceed $d/100$.

2.1.1. CLIMATIC CONDITIONS

Wind loads to be considered for the design of structures shall be taken from the Eurocode 1 rules (EN 1991-1-3): zones 4 (28 m/s), roughness IIIb, force coefficient equal to 1.80. Any structure situated in an unfavorable geographical area with regard to this load case shall be subject to a special design basis in order to meet the applicable standards.

2.1.2. DESIGN RULES

2.1.2.1 Aluminium structures

Design rules for aluminium structures - most recent edition of DTU rules (currently, July 1976).

Applicable standard for the execution of structures: NF EN 1090-2 and Eurocode 9.

2.1.2.2 Steel structures

Design rules for steel structures CM 66 » - most recent edition.

Applicable standard for the execution of structures: EN 1093 and Eurocode 3.

2.1.2.3 Concrete blocks

Concrete blocks shall be of "weight" type with minimum reinforcement.

The concrete to be used shall have an ordinary Portland cement (OPC) content of 400 kg/m³ (s' 28=300 bars - s28=25 bars).

General technical requirements

2.1.2.4 Design calculations for plastic elements

Adapt the CM 66 rules using a safety coefficient of 2 for the stresses.

2.1.3. MATERIALS

2.1.3.1 General remarks

The materials used shall all be first-choice materials suitable for their envisaged use and they shall be used in accordance with the rules of best industry practice for the profession and in compliance with the standards and regulations in force in France and in the Countries in which they are intended to be used.

The materials used shall not have any defect that is likely to compromise the durability of the structures. The equipment shall be easy to clean, maintain and service.

The materials shall be capable of withstanding harsh climatic conditions such as rain, snow, hail, condensation, dust and salt spray.

Operation must be guaranteed between - 20 and + 80 ° C.

2.1.3.2 Steels

Steels shall be either "hot finished" as per NF EN 10210 or "cold finished" as per NF EN 10219-1 and 2. The quality of the steels shall be stated on the production drawings and it goes without saying that the mechanical properties of the different types of steels must be taken into account for stability calculations.

All elements shall be manufactured in a covered, sheltered location.

After machining, welding, drilling, notching, etc. the elements shall be prepared prior to anti-corrosion treatment: brushing of welds, careful deburring, cleaning, shot peening and sand blasting.

The anti-corrosion treatment shall be performed by hot galvanization of a minimum of 80 µm and shall provide fault-free protection for at least the period of the ten-year guarantee.

No machining may be carried out once the parts have undergone anti-corrosion treatment.

All fasteners and hardware (including hinges) shall be made of 18/10 stainless steel (NFE 25.033).

2.1.3.3. Aluminium

The reference standard is NF EN 573-1. Parts used in a supporting structure shall be chosen from the "6000" series. For parts which are not used in a supporting structure, the "1000" series shall be acceptable.

The alloys are to be weldable.

The parts shall be carefully deburred and the welds shall be brushed before any protective treatment.

The visible parts of equipment shall be treated by the application of paintwork performed according to a "Qualicoat"-type procedure.

General technical requirements

2.1.3.4. PMMA

The PMMA shall meet at least the following characteristics:

	Flat parts machined "cast" PMMA	Flat parts unmachined "extruded" PMMA
• Opal white (values for a test piece of 3mm thick)		
• Tensile strength	> 75 MPa	> 70 MPa
• Bending strength	> 130 MPa	> 120 MPa
• Bending modulus	> 3,250 MPa	> 3,000 MPa
• Unnotched CHARPY impact test strength	> 12 MPa	>10 MPa
• Expansion	< 1 mm / 1 m / 10°C	<1 mm / 1 m / 10°C
• Light transmittance	> 50 %	>33 %

The thermoformed panels shall be made of white, light diffusing, extruded PMMA in compliance with the sheet manufacturer's heating parameters.

Where parts made of PMMA are more than 100 cm high, they shall be hung from the top by an adhesive PMMA cleat.

The thickness of the sheets shall be calculated in compliance with the tensile strength standards set out above.

2.1.3.5. Polycarbonate

The polycarbonate sheet shall meet at least the following characteristics:

- Uncoloured appearance
- Density > 1.2 g/cm³
- Tensile strength: 60 Mpa
- Expansion < 0.7 mm / 1 m / 10°C
- Light transmittance > 90%

2.1.3.6. Expanded foam

These following characteristics must be met:

- Material 9010 white PVC
- Density > 50 g/cm³
- UV-stabilized: 14 MPa
- Shore hardness D > 75
- Expansion < 1 mm / 1 m / 10°C

2.1.3.7. Paint

Painted parts must have an even appearance across their entire surface.

Defects such as pores, fissures, grains of dust, runs or waves of paint shall not be tolerated.

General technical requirements

Samples of painted rough parts shall be tested and accepted by RENAULT, after having undergone the following tests performed by a certified body:

- Colour based on a LAB test with a MINOLTA 508 D colorimeter with D65 illuminant and the observer at 10° and specular component included (the tolerances in the CIELAB colour space are L +/- 1, a +/-1.5, b +/- 1.5).
- Gloss at 40 °: based on a test according to NF T 30064 standard.
- Gloss at 60 °: based on a test according to NF T 30064 standard
- Adhesion: resistance to peeling based on grid test.
Class 1, as per P UW 150 1. NF T 30038 standard
- Colourfastness:
QUV as per NF T 30036 after 200 hours of exposure.

Samples of each of the elements shall be supplied, upon request, to RENAULT for inspection.

2.1.4. ELECTRICAL EQUIPMENT

Assemblies with electrical equipment shall comply with the essential safety requirements of the European Union. Within this framework, the supplier shall obtain a certificate (for each type of equipment) which must clearly state the compliance of the assemblies, and thus of the components, with:

- requirements relating to the safety and protection of users and all other persons (directive 73/23/EEC without any lower voltage threshold)
- requirements relating to electromagnetic compatibility (directive 89/336/EEC).

The rating plate on each item of equipment shall display the CE mark indicating compliance with these requirements.

The regulations relating to low-voltage signage in force in each of the countries concerned shall be complied with taking climatic conditions into account.

In addition, the following requirements shall be met:

Electrical equipment shall be compliant with the standards in force from the series NFC 15-100, NFC 20-010 and NFC 20-030, NFC 71, NFC 32 for France and the IEC 60364 international standard.

This concerns the following in particular:

- Category one electrical installations and low-voltage illuminated signage installations.
- The fire behaviour of electrical equipment and the degree of protection of enclosures,
- Flexible and rigid low-voltage cables.

In addition, the equipment shall comply regulations relating to the suppression of interference in inhabited areas and shall thus be delivered with interference suppression.

General technical requirements

2.1.4.1 IP rating

All the electrical equipment shall have a protection rating of at least IP 44-D.

2.1.4.2 Protection against electric shock

All equipment shall be "class 1".

2.1.4.3 Fasteners

The converters shall be placed in areas not subject to standing water.

The cables and sheaths shall be fastened to structures at 50 cm intervals.

2.1.4.4 Cable routing

Every cable or sheath passing through a metal part shall be routed through a cable gland.

Connection boxes.

An IP 44 sealed plastic connection box shall be provided at the inlet to each assembly. This box shall be equipped with a 5-input connection pin for 4 mm wiring.

All the connection boxes shall have the markings P1+P2+P3+T+N.

2.1.4.5 LEDs

The white LEDs used shall have the following characteristics:

- Lifetime: 50,000 hours for a loss of initial luminous flux of 50 % at the end of the period
- 5 year guarantee for operation 10 hours per day with a maximum loss of luminous flux of 20 %
- Operating temperature of LEDs: between - 20° C and +50 °C.
- Minimum protection index: IP 67
- The LEDs used must comply with the following international standards: IEC 62504 TS Ed. 1, IEC 61231, IEC 62560 Ed 1, IEC 62031 LED module safety, IEC 61347-2-13 LED control gear.

2.1.4.6 Converters

The power supply converters for the LEDs shall have the following characteristics:

- Wide power supply voltage range (100 to 300 volts)
- Reversible protection against increase in temperature and overload
- Protection against short-circuits with automatic restart
- Minimum protection index: IP 67
- Operation compliant with: EN 55015, EN 61000-3-2, EN 61547, EN 61558-2-17

General technical requirements

2.1.5. FASTENERS AND HARDWARE

All fasteners and hardware used shall be made of stainless steel (non-magnetizable).

Aluminium "pop" rivets are accepted as long as the steel rods are systematically removed.

For welding, the wires and electrodes are to be compliant with NF 81.830.

2.1.6. ANCHORING SYSTEMS AND FASTENINGS

The plinths for all equipments shall be completely removable without having to remove another element of the assembly. The plinths shall cover the attachment plates or fastenings. The attachment plates shall be easily accessible once the plinths have been removed.

For each of the assemblies which require a foundation block or fastening to a separate structure, the signwriter shall provide the elements necessary, as well as the conditions to be used to make design calculations for these elements (wind conditions and design calculation methods).

2.1.7. IDENTIFICATION PLATE

Each finished product shall be marked with a metal identification plate on the structure which shall show at least the following information:

- Name of the signwriter
- Product code and batch
- Month and year of manufacturing
- The CE Marking if it is illuminated.

2.1.8. STORAGE

The finished products shall be stored in a dry and well-ventilated location.

RENAULT inspectors shall be able to have access to them at any time.

2.2. Guarantees

The suppliers undertake to offer the guarantee conditions below for their products:

- 2 year guarantee on the installation against defects and faulty workmanship,
- 5 year guarantee on the electrical equipment including the LEDs and converters,
- 5 year guarantee on the adhesive elements,
- 5 year guarantee on digital printing (anti UV treatment),
- 5 year guarantee on workshop-lacquered sheet metal,
- 5 year guarantee on the chrome-plated diamonds,
- 7 year guarantee on sheet metal and profiles pre-lacquered by the aluminium manufacturer,
- 10 year guarantee on the internal structures,
- 10 year guarantee on the PMMA acrylic panels.

2

General remarks

Overview

Description

These façade banners are an economical adaptation of the façade markings used in the dealerships.

Using the same metal mesh as on dealer sites, they have standardized dimensions.

They are to be used on secondary network façades with low visibility only and under no circumstances in dealerships (R1) or in the secondary network (R2) with strong visibility which will apply the same devices as the dealers.



Couleurs et matières

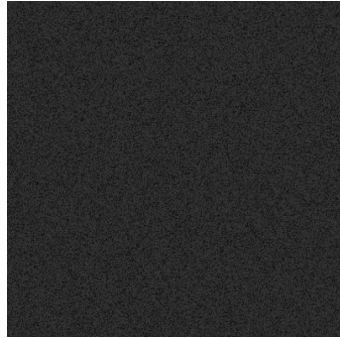

Metallic dark grey

- Post-lacquered aluminium sheeting, 20/10 mm thick
- Satin finish with 30% gloss
- Metallic finish
- Ref. AXALTA - Alesta IP Anthracite Grey X930500089



Dark grey equivalent to RAL 7021

- Pre-lacquered aluminium sheeting, 15/10 mm thick
- Satin finish with 40% gloss



RAL 9005 matt black

- Pre-lacquered aluminium sheeting, 15/10 mm thick
- Matt finish with 2% gloss



Chrome brillant

- PMMA diffusant injecté avec métallisation sous vide et vernis de protection brillant

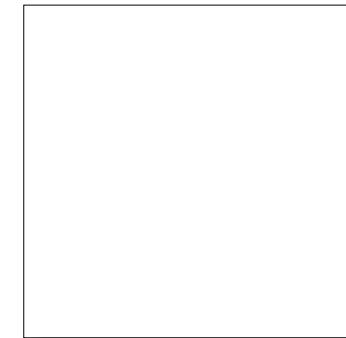

Pure White

- Satin or matt adhesive
- Light diffusing PMMA Light transmittance 50%

3

Technical principles

Overview

Principle

The façade banners for secondary network sites feature:

- the Renault signature, made up of the diamond and the Renault word,
- the Site Name.

Two layout drawings defining the proportions between the diamond and the Renault word are recommended:

- layout v1, for banners 1,733 mm in height,
- layout v2, for banners 783 and 1,332 mm in height.

Contrary to the dealers, the banner is of standard dimensions (and not put in the length or the height of the facade) and always have a non-illuminated Site Name.

3 standard banners are available.

Key

- ① 1,733mm banner
- ② 1,332mm banner
- ③ 783mm banner

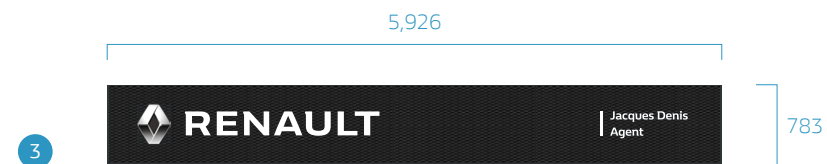
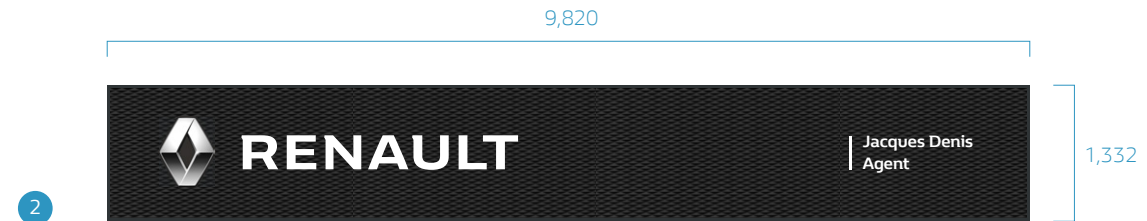

Layout for 1,733mm banners

Principle

This layout shows the proportions between the different components featuring on the 1,733 mm-high banners for secondary network façades.

The banner is realized on the basis of panels of 1942 mm length.

The height of the Renault word is calculated based on the letter "E".

Key

- 1 Dark grey woven mesh
- 2 3D diamond, LED-backlit, with light-diffusing chrome finish
- 3 Renault word in backlit box letters, with white PMMA face, 15/10th mm thick aluminium sheet edges, RAL 7021 dark grey finish
- 4 Matt white adhesive strip cemented on a RAL 9005 matt black aluminium sheet
- 5 Site Name in matt white adhesive cemented on a RAL 9005 matt black aluminium sheet
- 6 "Agent" wording in matt white adhesive cemented on a RAL 9005 matt black aluminium sheet

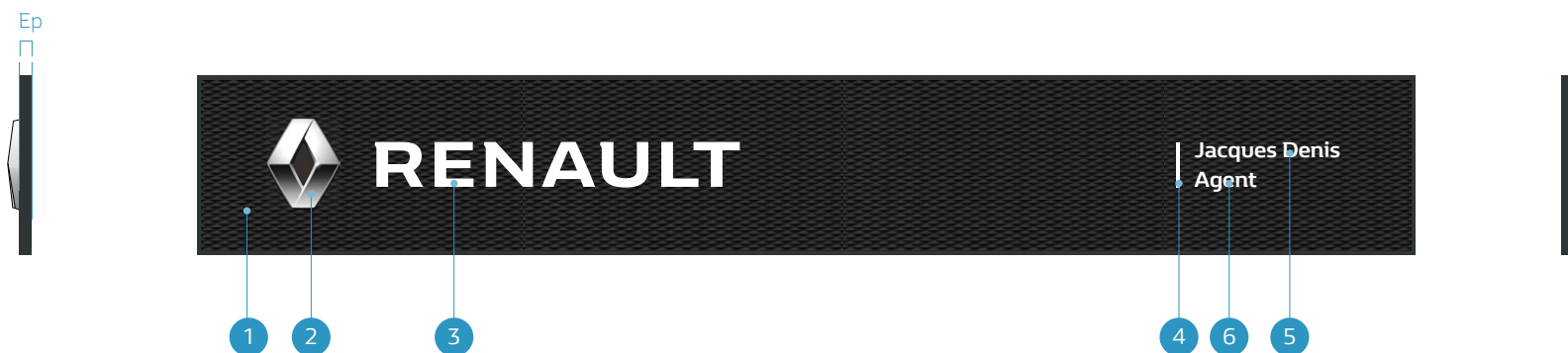
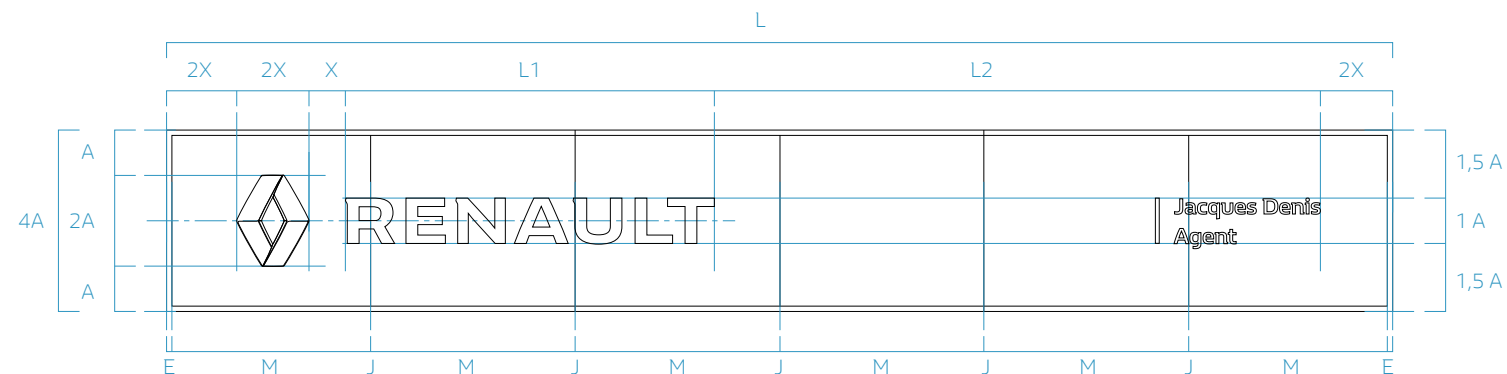

Dimension	1,733 Banner
A	433
2A	866
4A	1733
1,5A	650
X	344
2X	688

Dimension	1,733 Banner
E	45
M	1942
J	5
L1	3496
L2	5862
L	11767
Ep	87

Layout of Site Name v1

Principle

This layout shows the proportions between the different components of the Site Name.

The height of the Site Name is always equal to 33% of that of the Renault word.

NOTE: Dimension "e1" represents the thickness of the lettering.

Key

- 1 Matt white adhesive strip cemented on a RAL 9005 matt black aluminium sheet
- 2 Site Name, Renault Life bold typography, standard tracking, capitals on first letter of surnames and first names, in matt white adhesive cemented on a RAL 9005 matt black aluminium sheet
- 3 "Agent" wording, Renault Life bold typography, standard tracking, capitals on first letter of surnames and first names, in matt white adhesive cemented on a RAL 9005 matt black aluminium sheet

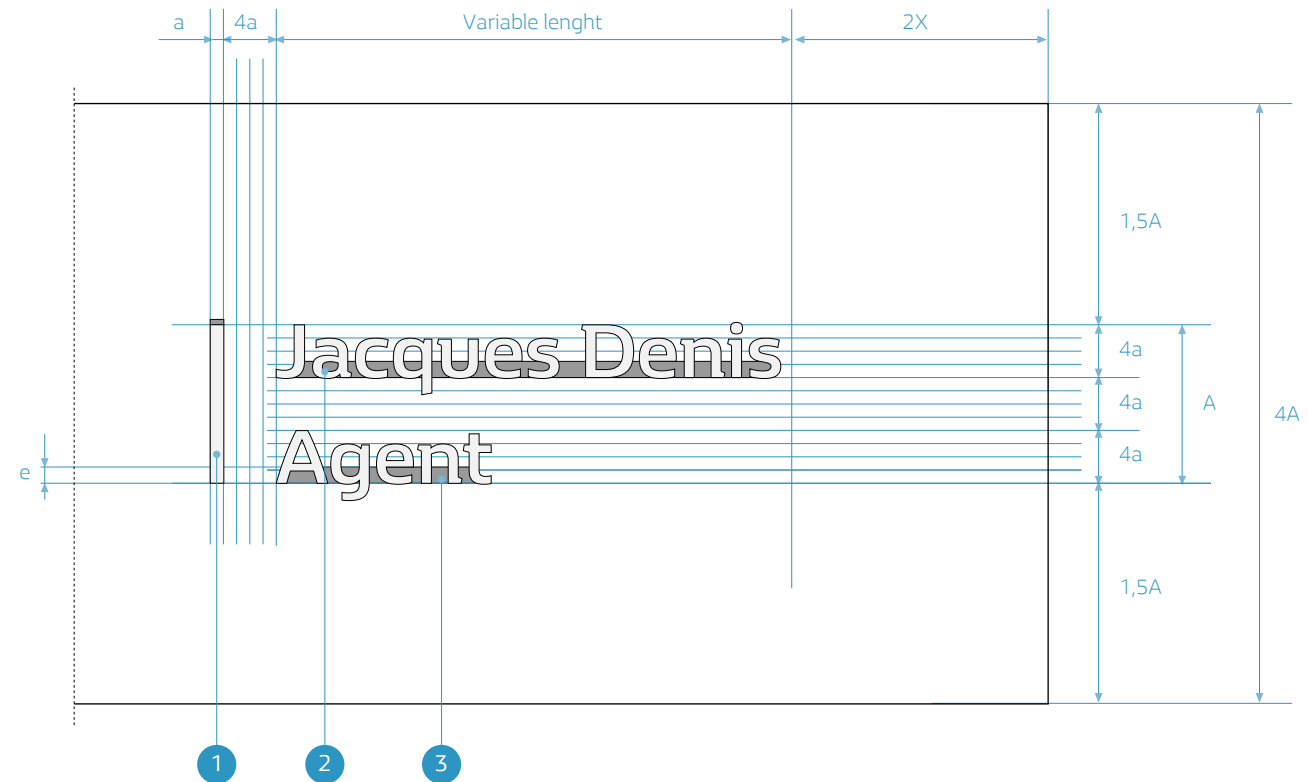

Dimension	1,733 Banner
4A	1733
1,5A	650
A	433
2X	344
a	36
4a	144,3
e	45

Layout for 1,332mm banners

Principle

This layout shows the proportions between the different components featuring on the 1,332 mm-high banners for secondary network façades.

The banner is realized on the basis of panels of 1942 mm length.

The height of the Renault word is calculated based on the letter "E".

Key

- 1 Dark grey woven mesh
- 2 3D diamond, LED-backlit, with light-diffusing chrome finish
- 3 Renault word in backlit box letters, with white PMMA face, 15/10th mm thick aluminium sheet edges, RAL 7021 dark grey finish
- 4 Matt white adhesive strip cemented on a RAL 9005 matt black aluminium sheet
- 5 Site Name in matt white adhesive cemented on a RAL 9005 matt black aluminium sheet
- 6 "Agent" wording in matt white adhesive cemented on a RAL 9005 matt black aluminium sheet

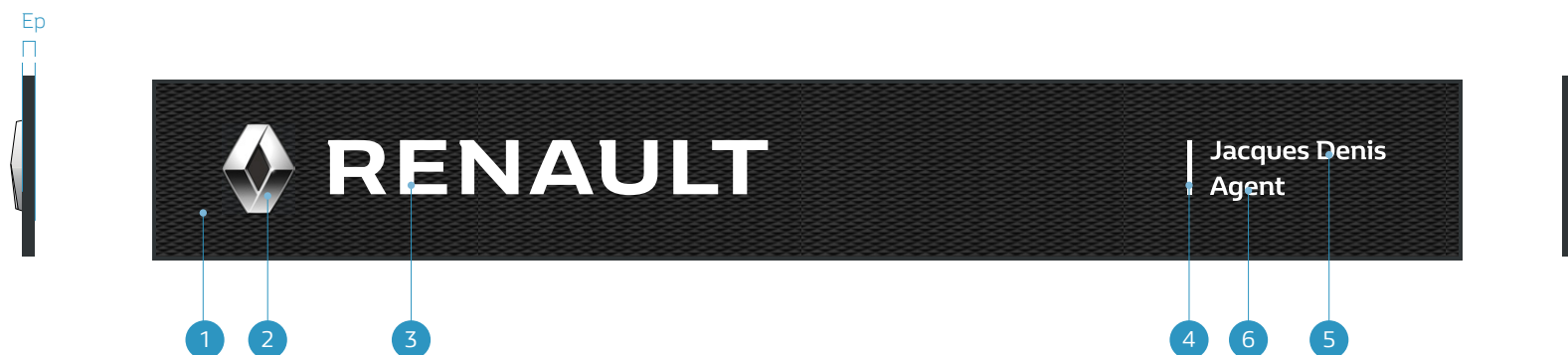
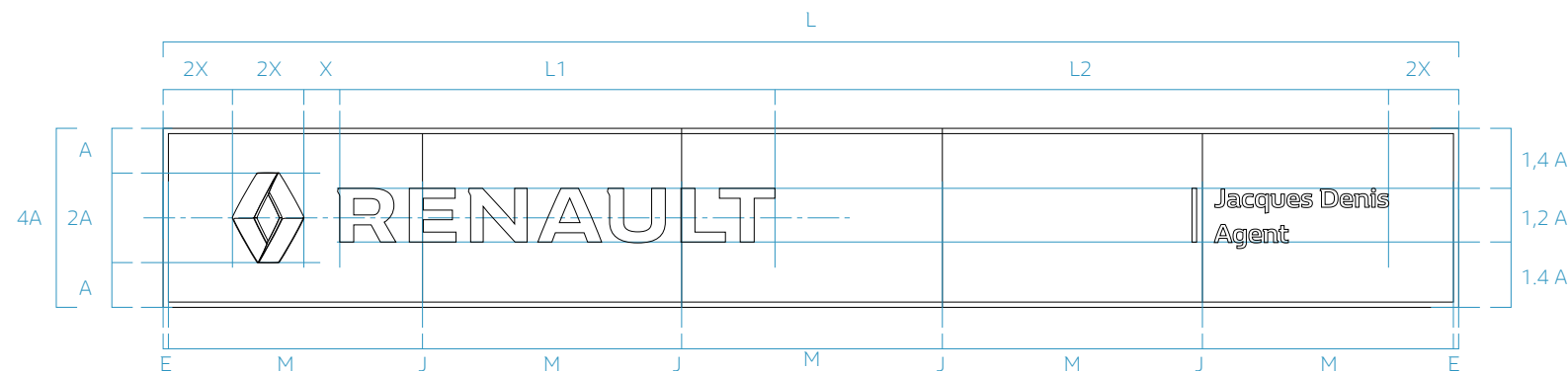

Dimension	1,332 Banner
A	333
2A	666
4A	1332
1,2A	402
1,4A	466
X	268
2X	536

Dimension	1,332 Banner
E	45
M	1942
J	5
L1	2909
L2	5035
L	9820
Ep	87

Layout for 833mm banners

Principle

This layout shows the proportions between the different components featuring on the 783-high banners for secondary network façades.

The banner is realized on the basis of panels of 1942 mm length.

The height of the Renault word is calculated based on the letter "E".

Key

- 1 Dark grey woven mesh
- 2 3D diamond, LED-backlit, with light-diffusing chrome finish
- 3 Renault word in backlit box letters, with white PMMA face, 15/10th mm thick aluminium sheet edges, RAL 7021 dark grey finish
- 4 Matt white adhesive strip cemented on a RAL 9005 matt black aluminium sheet
- 5 Site Name in matt white adhesive cemented on a RAL 9005 matt black aluminium sheet
- 6 "Agent" wording in matt white adhesive cemented on a RAL 9005 matt black aluminium sheet

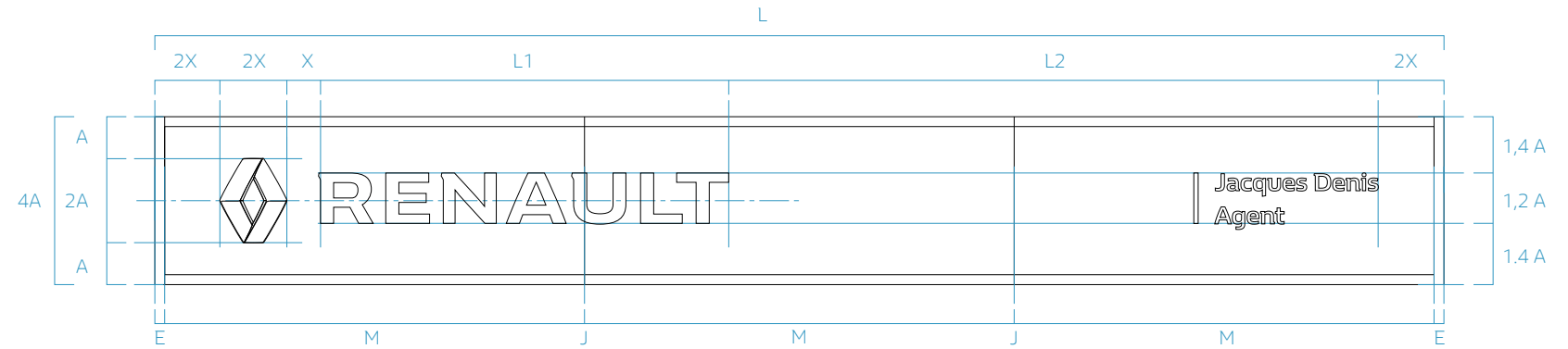

Dimension	783 Banner
A	196
2A	391
4A	783
1,2A	235
1,4A	274
X	152
2X	304

Dimension	783 Banner
E	45
M	1942
J	5
L1	1650
L2	3212
L	5926
Ep	87

Layout of the site name v2

Principle

This layout shows the proportions between the different components of the Site Name featuring on the 783 and 1,332 mm-high banners for secondary network façades.

The height of the Site Name is always equal to 33% of that of the Renault word.

NOTE: Dimension "e2" represents the thickness of the lettering.

Key

- 1 Matt white adhesive strip
- 2 Site Name, Renault Life bold typography, standard tracking, capitals on first letter of surnames and first names, in matt white adhesive cemented on a RAL 9005 matt black aluminium sheet
- 3 "Agent" wording, Renault Life bold typography, standard tracking, capitals on first letter of surnames and first names, in matt white adhesive cemented on a RAL 9005 matt black aluminium sheet

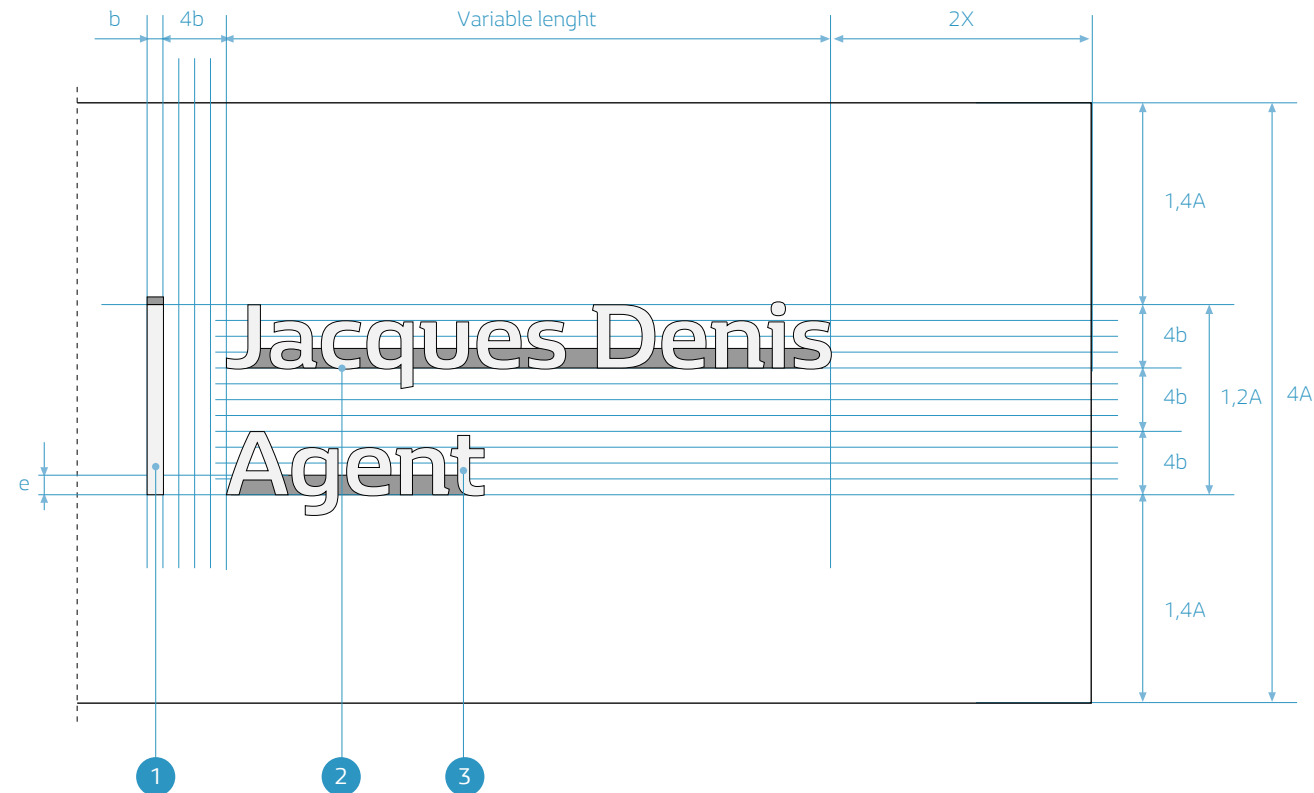

Dimension	783 Banner	1,332 Banner
4A	783	1332
1,4A	274	466
1,2A	235	402
2X	304	536
b	19	33,5
4b	76	134
e	24	41

Use of signature layout drawings

Choice of layout to use

The table opposite shows the signature layouts and corresponding diamond sizes used on the banners for secondary network façades.

- Layout v1 is used with banners 1,733 mm in height.
- Layout v2 is designed to address the potential impact deficit (reduced height of Renault word) with the lower height façade banners.

	783mm Banner	1,332mm Banner	1,733mm Banner
Layout v1			●
Layout v2	●	●	

Renault word layouts

Description

The table opposite gives the positioning dimensions for the Renault word lettering on the banners of secondary network façades.

NOTE: The height of the Renault word is calculated based on the letter "E".

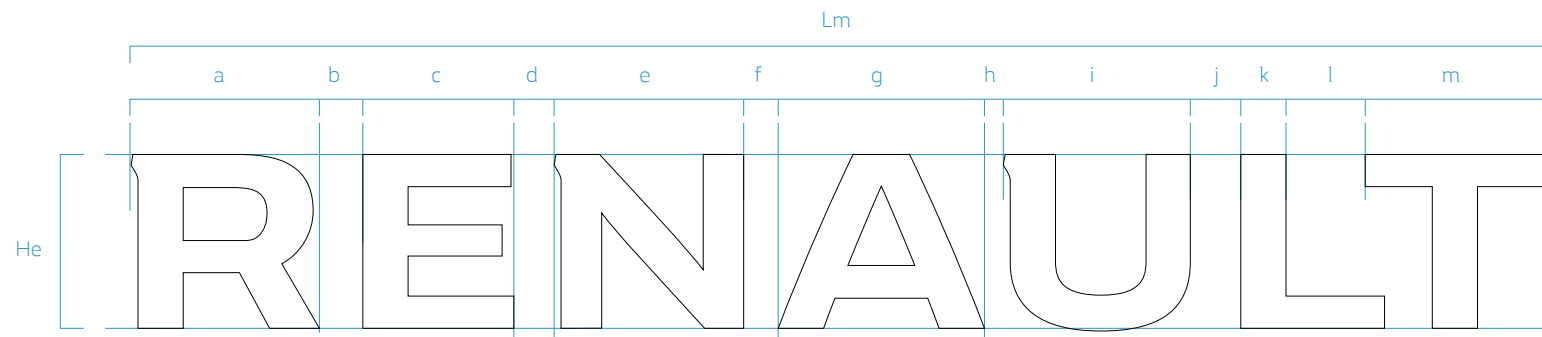

	Layout v2		Layout v1
Dimens	783 Banner	1332 Banner	1733 Banner
ion	228	402	430
He	1853	3268	3496
Lm	247	435	466
a	57	100	107
b	198	349	373
c	53	94	100
d	248	438	469
e	45	81	85
f	270	477	510
g	26	44	48
h	245	432	462
i	66	116	125
j	59	105	112
k	104	183	196
l	235	414	443

m

Lighting of secondary network banners

Description

Illumination of the lettering face by chain-LEDs mounted in the back of the banner.

The converter, which is common for all the letters, is mounted in the banner.

Performance characteristics

Chain LED with minimum IP65 protection rating.

Temperature: 6,500° K Cool White.

Mean luminance: 250 cd/m² with a maximum of 300 cd/m².

The warranty for all LED lighting systems and parts is 5 years, subject to compliance with conditions of use and maintenance.

Light output reduced by 50% after 50,000 hours operation.

Minimum guaranteed lifetime: 50,000 hours.

Supply: 220 volts

12 volt converter with regulated voltage, IP 68 protection.

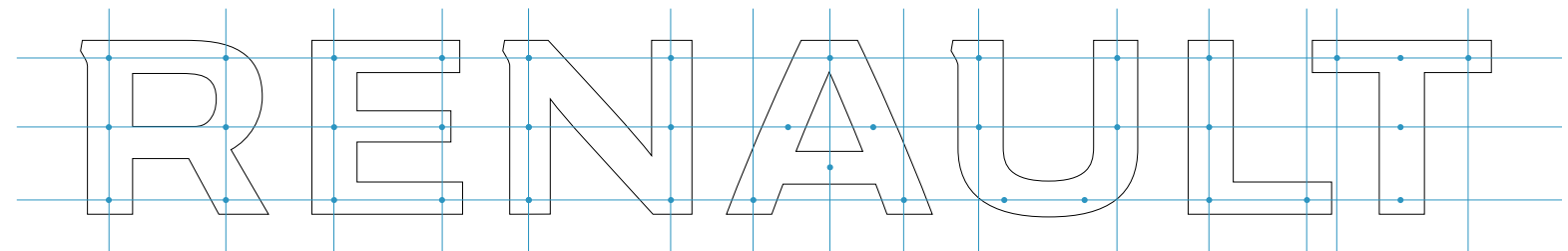
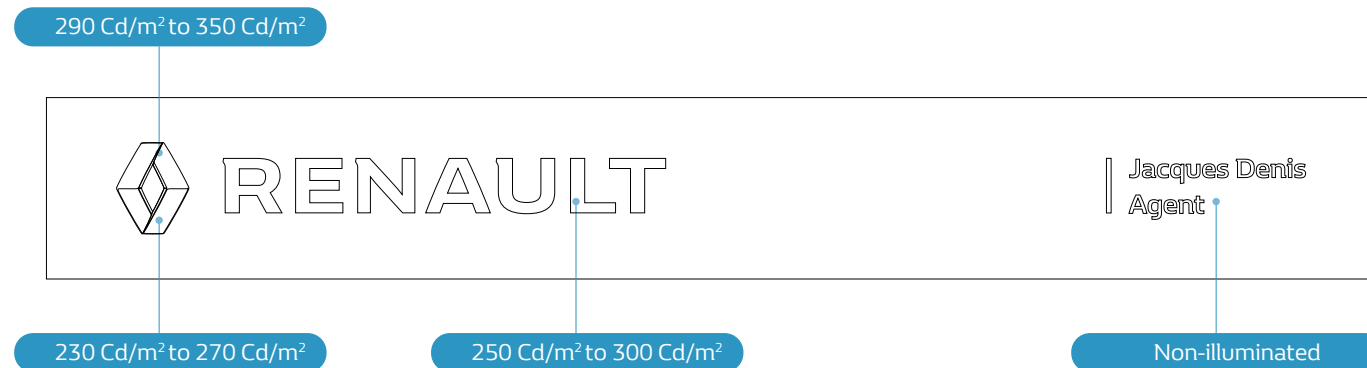

The dots are a schematic representation of the measurement points that should present similar light intensity values in order to obtain even lighting across each of the letters of the Renault word.

The readings, performed with a calibrated luminance meter, should ideally be performed without light interference and at a distance of between 1 and 2 m from the letter face.

3D diamonds are identical to those used on the facades of the dealerships.
A specific specifications describe the principles of lighting and the modalities of manufacturing
Various sizes of diamonds.

Description of the woven mesh

Principle

The woven-metal mesh is made of expanded aluminum sheet, 20/10th mm thick:

- initial format of sheet: 2,500 x 2,000 mm,
- format of finished module: 1,775 x 1,942 mm, 1,325 x 1,942 mm or 825 x 1,942 mm
- mesh size, L. 114.25 x Thk. 21 x H. 25 mm,
- painting: post-lacquered in dark grey metallic satin.

Approximate weight: 12 kg/m²

Behind the woven-metal mesh modules, set back by about 60 mm, a matt black aluminum panel provides a contrast to highlight the light effects on the woven-metal.

Key

- 1 Woven-metal in dark grey metallic satin
- 2 Rear panel in pre-lacquered RAL 9005 matt black aluminium sheet, 15/10th mm thick

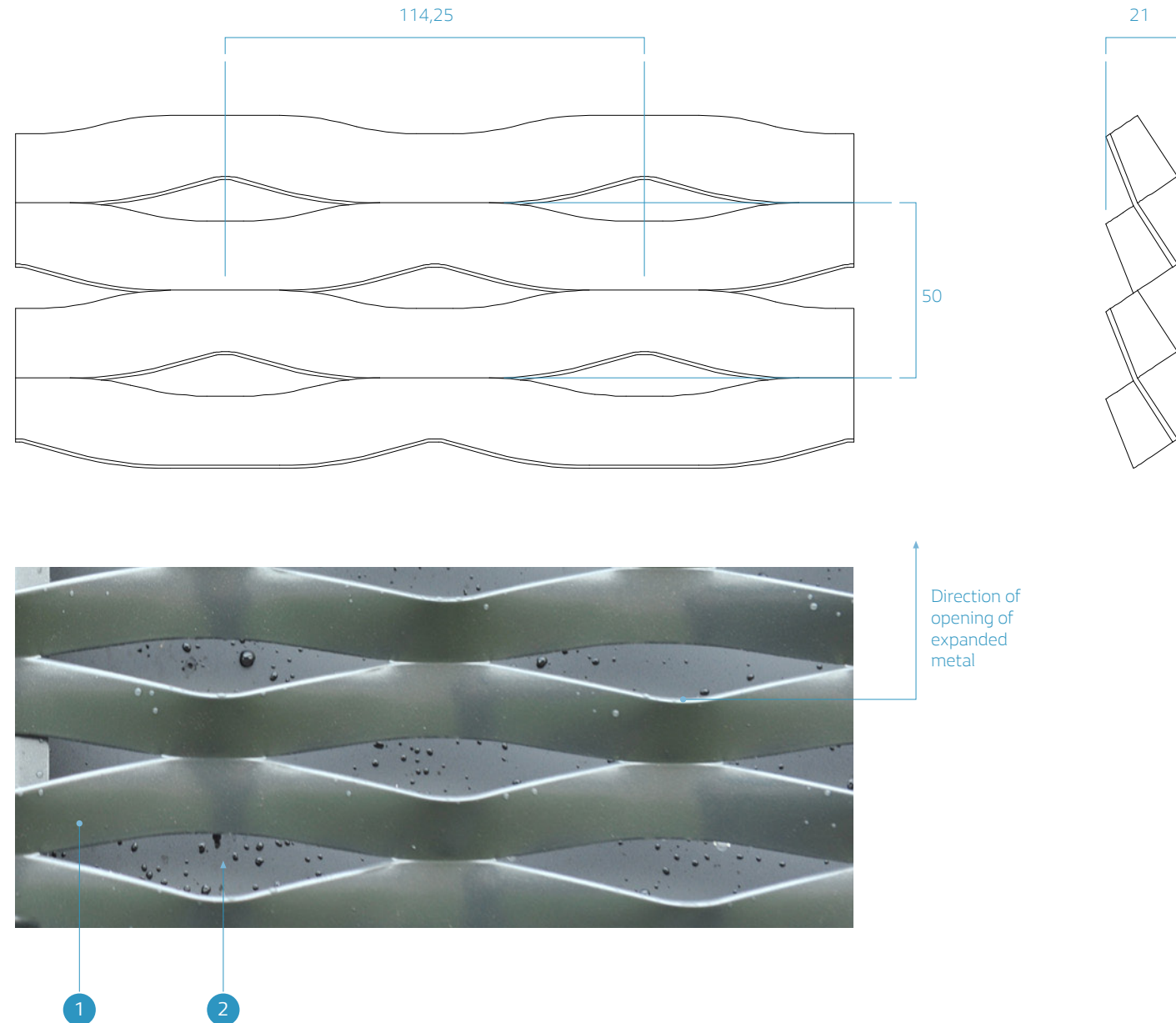

Expected result

Constraints

- It is important to comply with the colour, metallization and gloss of the paint in order to achieve the required visual effect.
- The opening of the metal mesh is always directed upward.
- The junctions between mesh modules must be carefully executed and regular.
- The woven-metal mesh modules must be sufficiently flat and dimensionally uniform in the implementation of the mesh in order to provide good visual continuity, especially at connections.

Key

- 1 General appearance of a mesh module
- 2 Vertical junction between two mesh modules

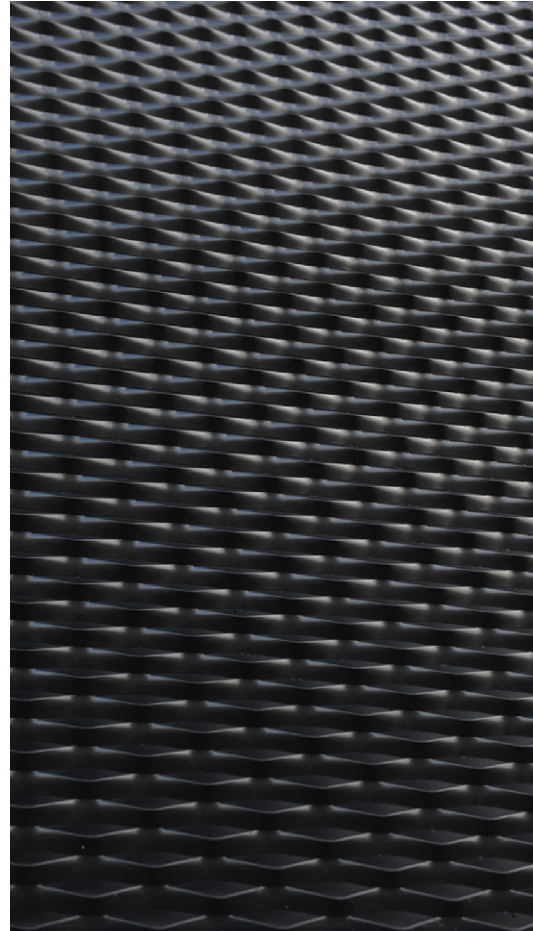

1

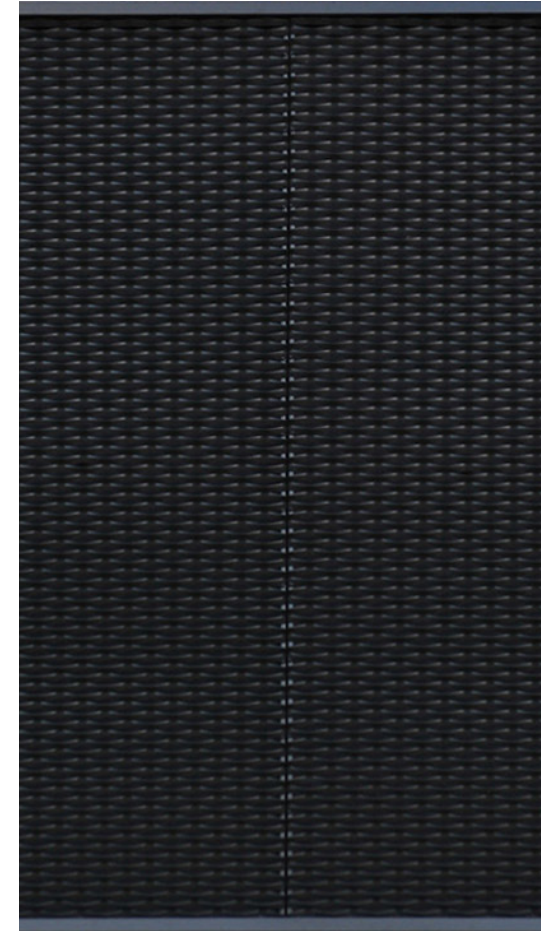

2

Manufacturing

Principle

If the height of the façade is less than 2.40 m, the cladding shall comprise a homogenous surface with a peripheral frame and woven-metal mesh modules approximately of 1,942 mm length, with vertical joints between modules.

Particular care shall be taken to ensure the flatness of the mesh modules, which may require recutting of edges to release stresses generated by the forming of the expanded metal.

Key

- 1 Peripheral frame upright in aluminum sheet 20/10th thick, post-lacquered with dark grey metallic paint
- 2 Peripheral frame top rail in aluminum sheet 20/10th thick, post-lacquered with dark grey metallic paint
- 3 Woven-metal mesh module : 1,942mm length
- 4 Vertical junction between two mesh panels
- 5 Edge-to-edge joint centred on rail with alignment b

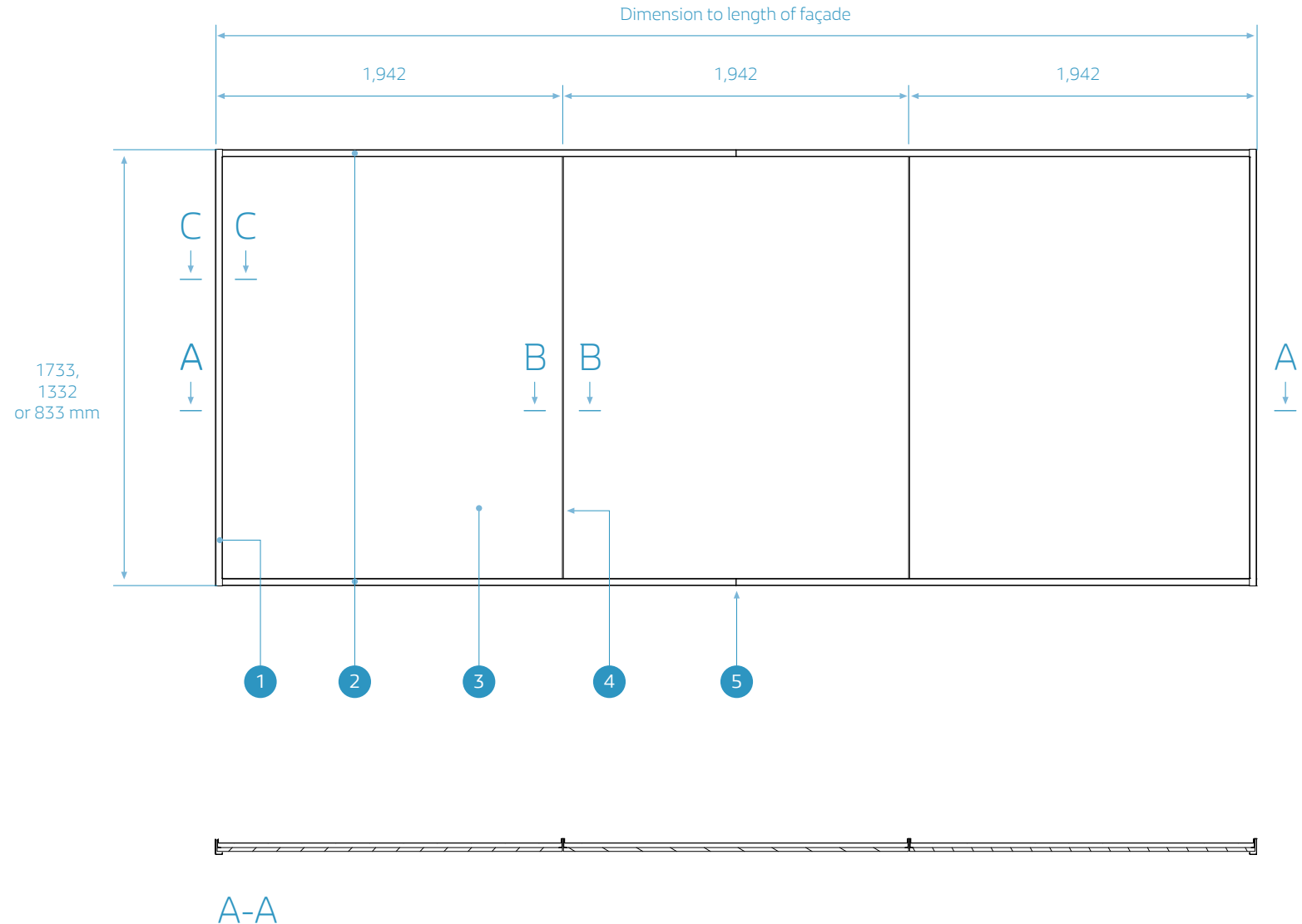

Details and assemblies

Principle

Note that the vertical joint between two mesh panels always comprises a recessed joint with a maximum width of 5 mm.

Key

- 1 Rear panel in pre-lacquered RAL 9005 matt black aluminium sheet, 15/10th mm thick
- 2 Woven-metal mesh module with 1,940 mm length
- 3 Perforated vertical angle in 3 mm aluminum, welded to back of mesh for stiffening
- 4 Aluminium alignment bracket post-lacquered with dark grey metallic paint
- 5 Rear element of peripheral frame for wall mounting, made of aluminum sheet 20/10th thick, post-lacquered with dark grey metallic paint
- 6 Peripheral frame upright in aluminum sheet 20/10th thick, post-lacquered with dark grey metallic paint

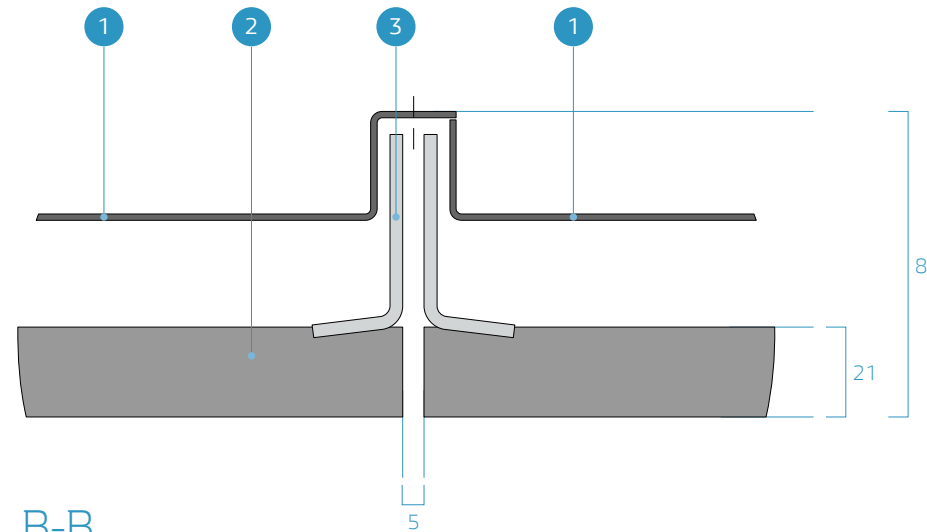

B-B
Vertical junction
between modules

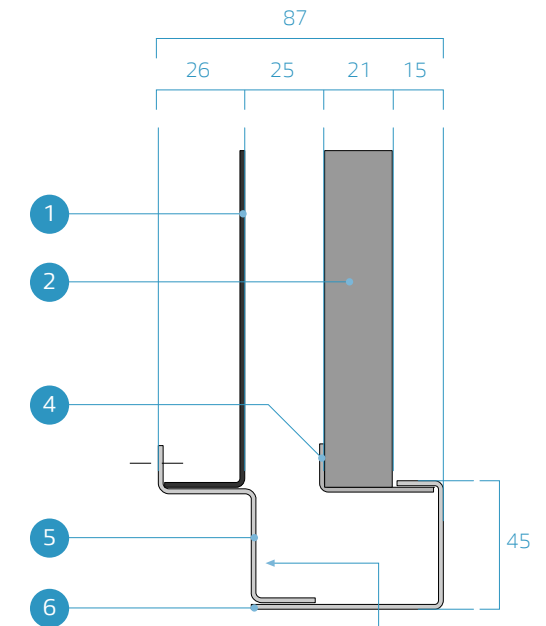

C-C
Cross-section
of peripheral frame

NOTE
This part, 50 mm in width, is located arranged at intervals of 400 mm to facilitate the evacuation of leaves or other material liable to pass through the mesh

Perforation of vertical pieces

Principle

The vertical angles used to stiffen the mesh modules are perforated at regular intervals to reduce visible shadows cast on the black background.

Key

- 1 Vertical angle piece in 3 mm aluminum, welded to back of mesh for stiffening
- 2 Oblong hole 100 x 12 mm

