



IMPLEMENTATION GUIDE
RETAIL CONCEPT WITHIN THE PRIMARY NETWORK
PRICE TOTEM

Version V1.0 OCTOBER 2023

01 GENERAL

COMPONENTS

1.1 PRICE TOTEM

A CONCENTRATE OF INFORMATION ON THE VEHICLE

PRINCIPLE

The price showcase is essential to give the customer a quick overview of all the information about the vehicle being presented (price, options, accessories, associated service packages).

The price showcase has several elements that are printed at the dealership:

> On the front:

- A USP sheet provided by Marketing.
- A price poster.
- An emission/consumption datasheet.

> On the back:

- An accessory sheet provided by Marketing.
- An A4-sized space for point-of-sale advertising (campaigns on after-sale offerings or other additional services), provided by Marketing.

INSTALLATION RULES

The updating of the media contained in the Price Totem is ensured by the dealer, to always be consistent with the vehicle on display.

The price totem is positioned next to each vehicle, on the driver's side, 600mm in front of the vehicle, allowing the door to open and preserving circulation between the car and the totem. It must also be parallel to the vehicle and inclined at 45° to the back wall.



1.2 COLORS & MATERIALS

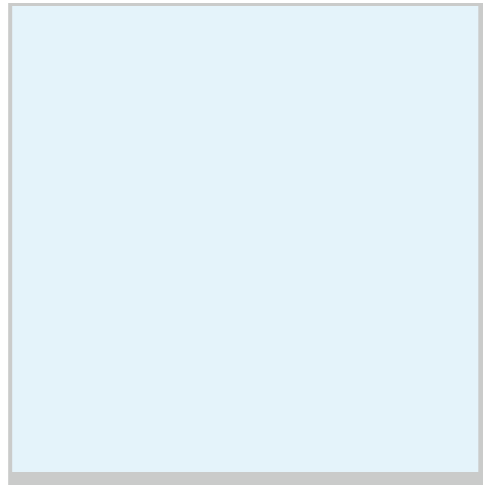

-extruded crystal PMMA,
12mm thick

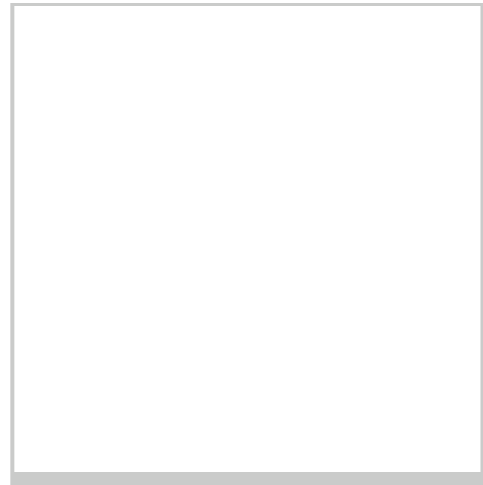

document holder

-anti-glare crystal PETG, 3mm
thick

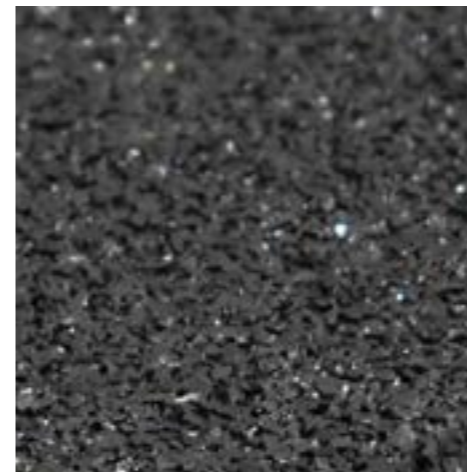

round support

-HET supplier
-brick made with recycled
rubber



Dacia Kaki

- for print
- RAL DESIGN 140 50 10

02

TECHNICAL PRINCIPLES

2.1 PRESENTATION

GENERAL CONCEPT

The price display module is made up of a PMMA crystal upright fixed in a round brick of recycled rubber. The weight of this brick holds everything together without the possibility of falling.

The upper part includes three A4 format visuals protected by a transparent panel. These visuals are printed by the dealer who updates them regularly as the vehicle's specifications evolve.

The price display module is only available in a double-sided version.

1 display price

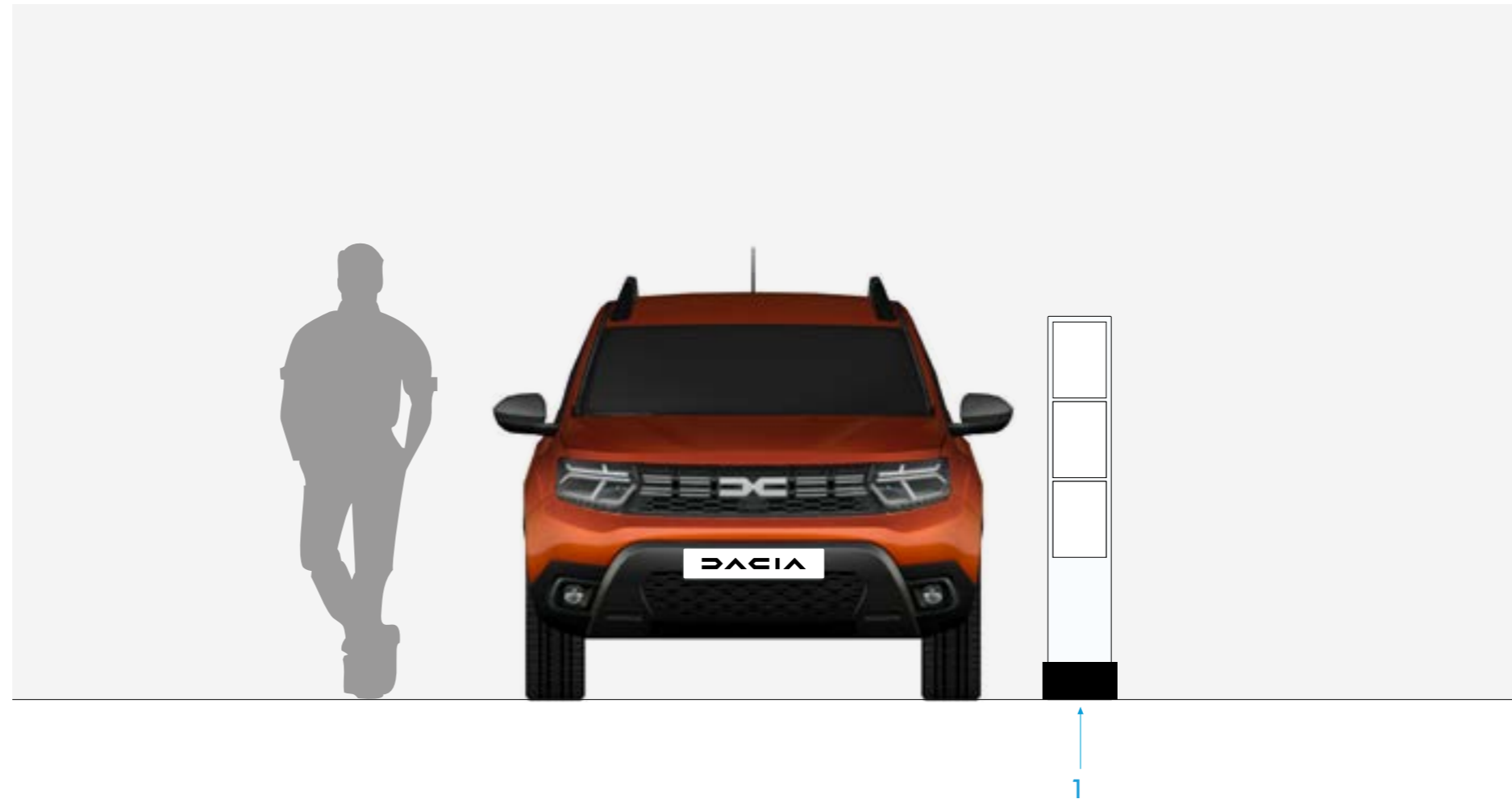

2.2 GENERAL DESCRIPTION

- 1 Anti-glare crystal PETG document holder, 3 mm thick, horizontal fold in the lower section. Fastened at the back at two points
- 2 A4 format visuals
- 3 Extruded crystal PMMA front panel, 12 mm thick.
- 4 Round recycled rubber brick

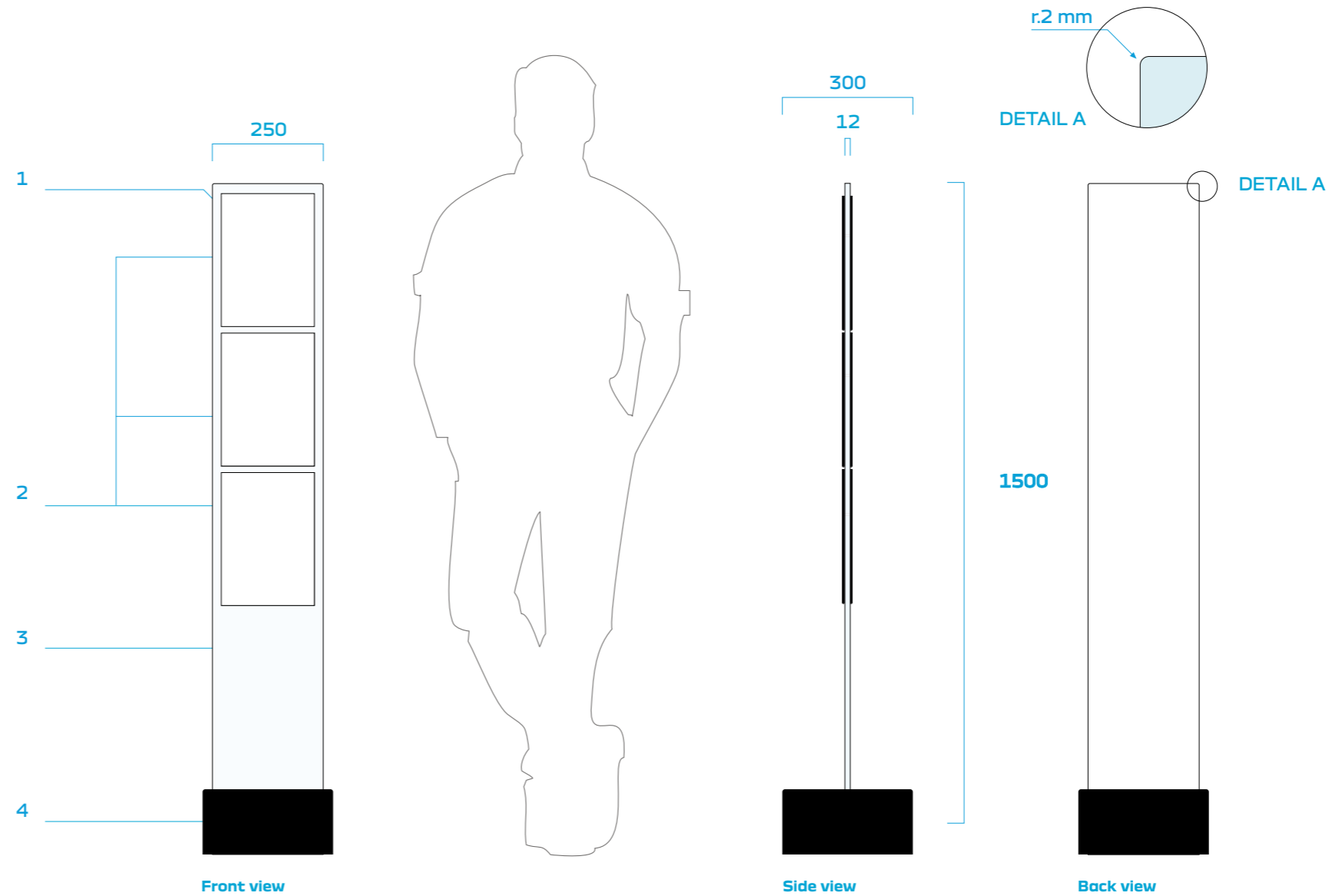

2.3 THE RUBBER BRICK

PRINCIPLE

The round rubber base acts as a weight that helps stabilize the module.

The base is entirely made of rubber which allows total adhesion to the concession floor.

The slot on the top of the brick allows you to forcefully accommodate the plexiglass plate which fits perfectly inside.



Round brick



Round brick + plexiglass
(already supplied)

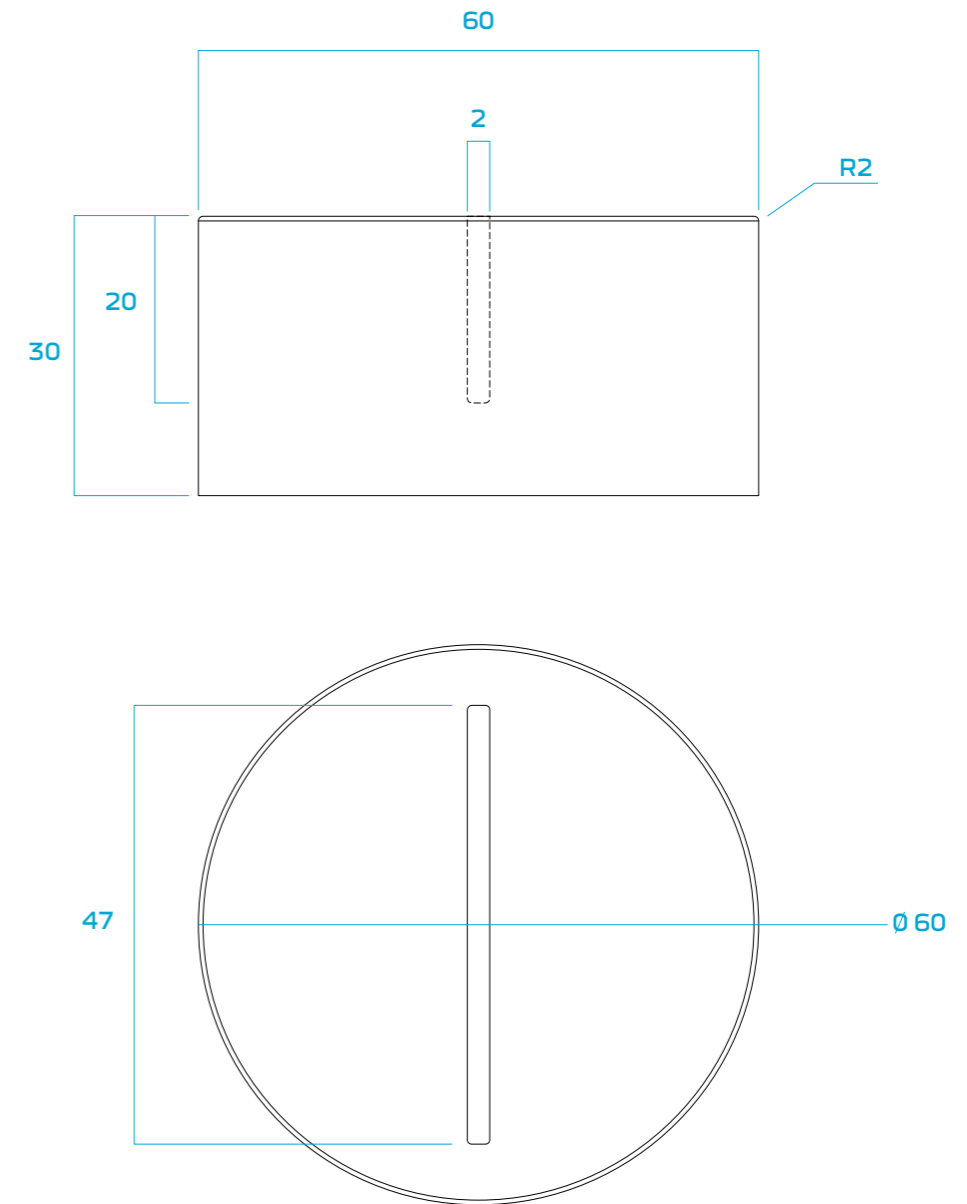

2.4 DOCUMENT HOLDER

PRINCIPLE

The visuals (90 g white paper) are placed in "document holders" held in place by screws on body.

These document holders, made of 3 mm crystal PETG, have a 180° horizontal fold at the bottom, enabling access from the top to change the visuals.

The document holder is attached at two points at the back by countersunk bolts in the body of the display module.

- 1** Front of the document holder
PETG, 3 mm thick, Include a tab for handling
- 2** Dummy outline of the A4 sheet
- 3** Drilled hole for the fastening of the document holder to the display module

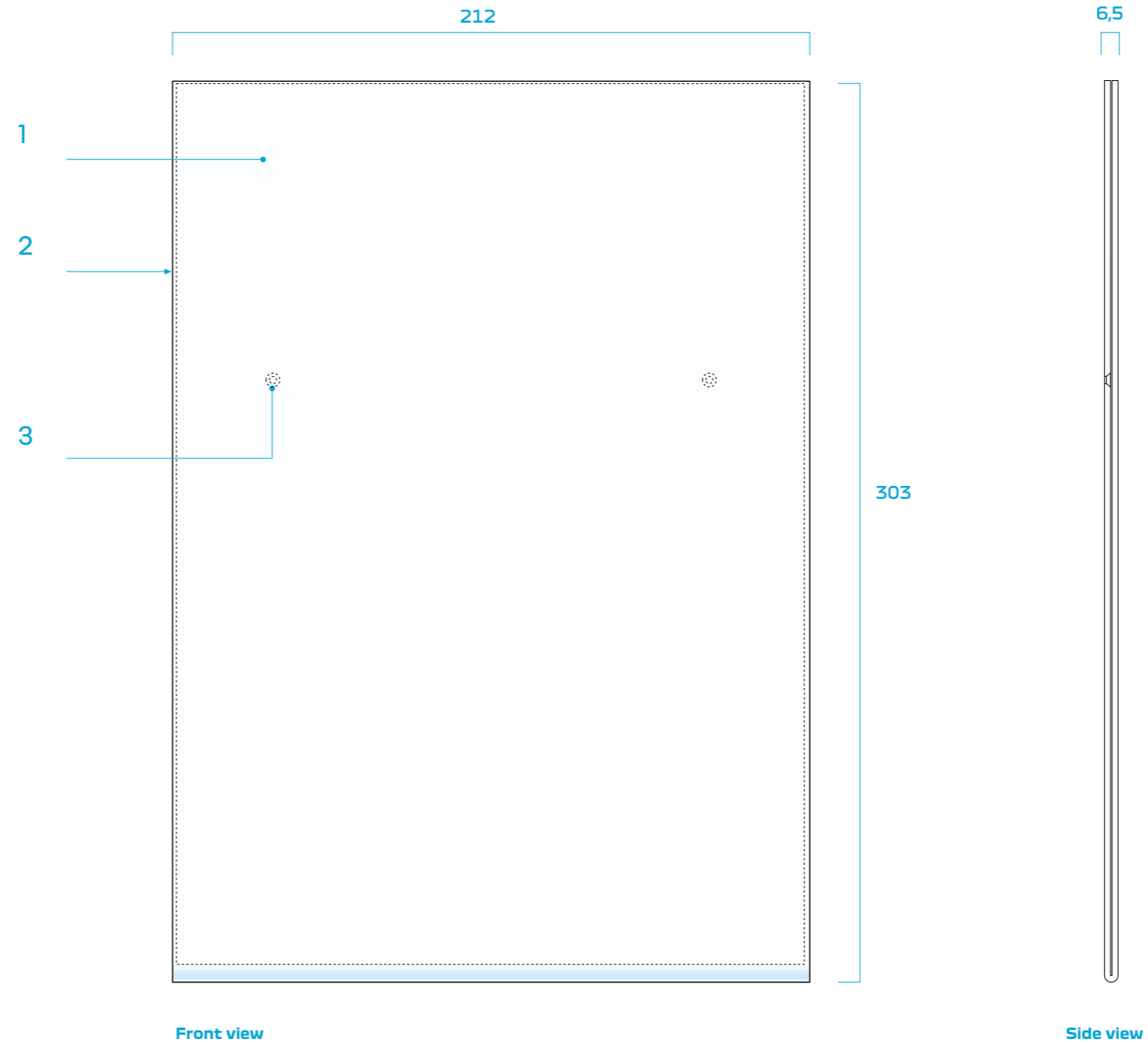

TECHNICAL PRINCIPLES
2.5 DIMENSIONS

PRINCIPLE

There are two side on the price display module:

- on one side there're three visuals
- on the other side, two visuals.



2.6 EXPLODED VIEW

- 1 Front cover
- 2 PETG document holder
- 3 Body of the display module
- 4 Rubber brick

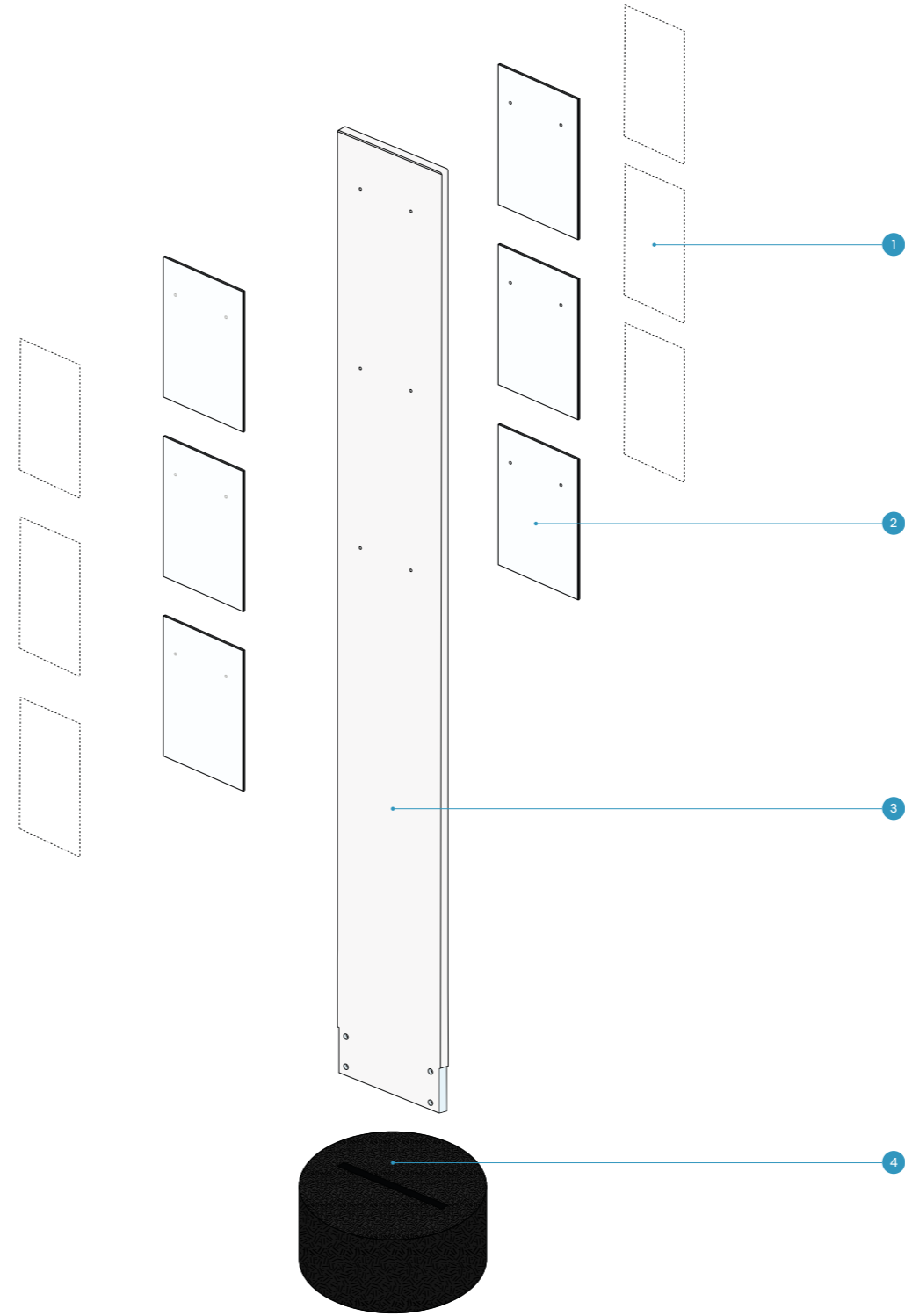

TECHNICAL PRINCIPLES

2.7 PRICE & USP

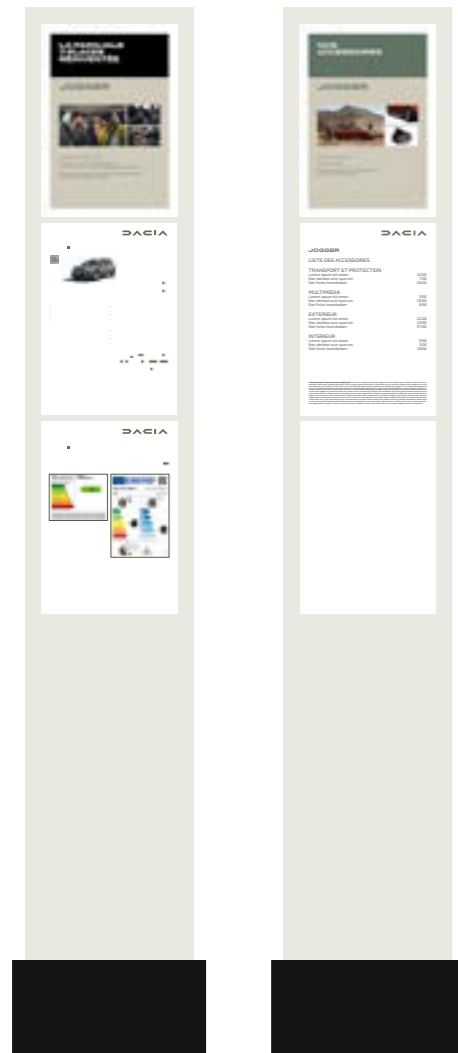

Recto

Verso

CORPORATE CONTENT

USP poster
QR Code with link to the product e-brochure

DEALERSHIP CONTENT

Price poster
- Model board price
- Price of the exposed version
- Price of the options of the vehicle exhibited
- Price of AXS of the vehicle exhibited (installation included)
- Financial offer, service included

Sheet with information on tires and energy class
or
Financing sheet (Mobilize) depending on country

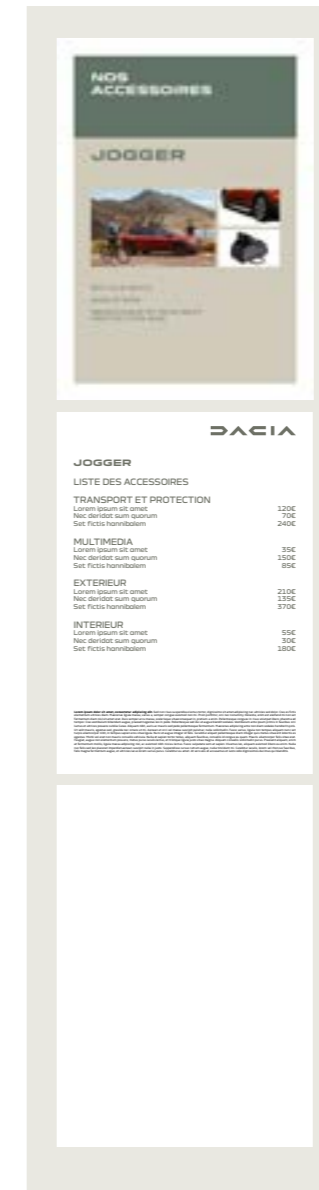

New AXS poster
QR Code with link to the AXS e-brochure

AFS seasonal offer linked to the new car.

2.8 DETAILS OF THE CONTENT OF THE VISUALS IN A4 FORMAT

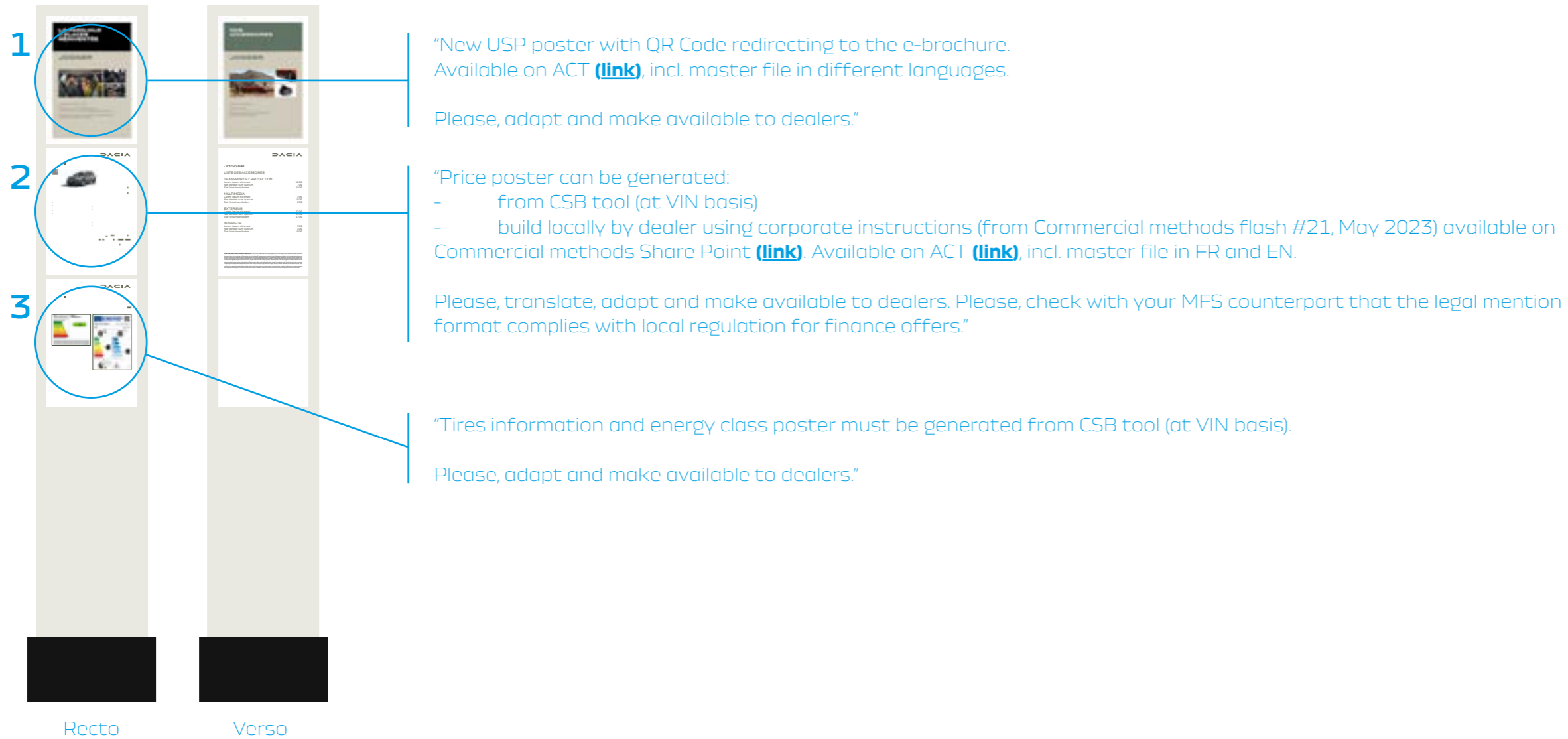

2.8 DETAILS OF THE CONTENT OF THE VISUALS IN A4 FORMAT

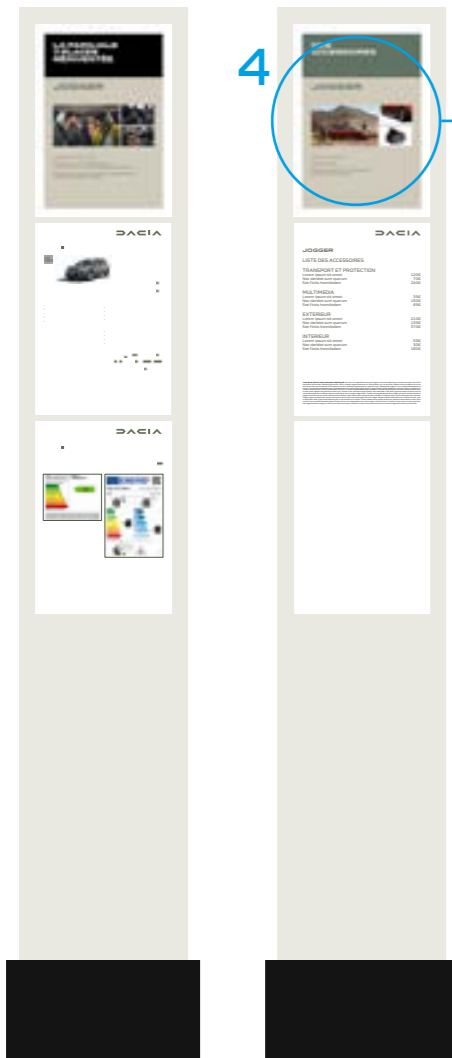

Recto

Verso

Please adapt & make available to dealers

Note for localisation:

QR code: link to AXS e-brochure (preferably), or to AXS section of Product plan, or to AXS online eshop/catalog (for instance CAX)

If you need to change the content, please mind:

Products: 3 AXS chosen by the country related to:

- Brand markers & product positioning
- Contribution to business
 - DO: keep good balance between exterior & interior AXS
 - DON'T: show same AXS on all models (ex. carpets)

Photos:

1 lifestyle AXS on the left + 2 focus studio on the right, related to the 3 "hero AXS

Templates available on ACT-AFS [\(link\)](#):

Modèles	N° de campagne
Spring	MI001503
Sandero	MI001379
Duster	MI001498
Jogger	MI001551
Logan	MI001378

2.8 DETAILS OF THE CONTENT OF THE VISUALS IN A4 FORMAT

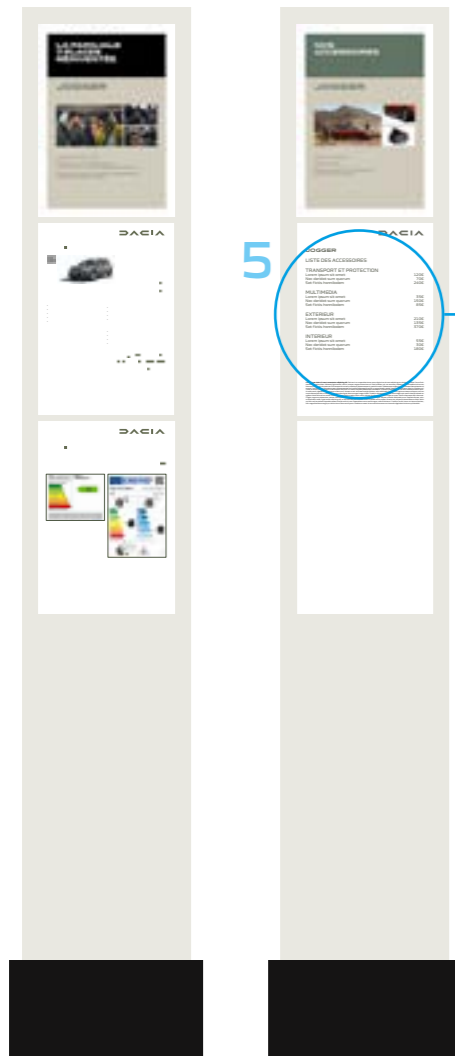

5

Please choose, as examples, the 3-5 the most important AXS seasonal or the most relevant AXS that you want to highlight on the given model.

Recto

Verso

03

TECHNICAL REQUIREMENTS

GENERAL TECHNICAL REQUIREMENTS

1.1 PREAMBLE

Dacia expects all those involved in the new interior design concept for Dacia sales spaces to meet their obligations in terms of results as per the requirements of the Technical Specifications. The general rules and specificities set out below are to be considered as the minimum necessary that has to be done to achieve the expected result.

1.2 SAFETY OF PERSONS AND PROPERTY

The supplier shall be able to provide proof that it has analysed the risks related to the services it is to provide and that its personnel and any sub-contractors have undergone sufficient training. Strict compliance with legislation in terms of safety and protection of workers is required.

1.3 RESPECT FOR THE ENVIRONMENT

Materials and methods which make it possible to reduce harm to the environment shall be used wherever possible (recyclable materials, energy-saving technologies, toxicity of materials and products used, etc.).

The supplier shall be able to provide proof that it has the various administrative permits (operating permit, environmental permit) necessary to manufacture the various items of equipment and that it complies with the operating conditions required by the legislation in force or by the specific operating conditions in the countries concerned.

A global approach such as the ISO 14001 standard is recommended.

1.4 QUALITY

The supplier shall be able to provide proof that it works in accordance with ISO 9000 quality assurance standards, formal certification being particularly recommended in this regard. The signmaker shall attach a specific Quality Plan to its offer to assure Dacia of its capacity to supply finished products and spare parts that are compliant with the contractual requirements, within the set time periods. It shall request its sub-contractors to do likewise.

The procedures applied must make it possible to :

- Be sure that the parts and products purchased, manufactured and supplied shall neither be used nor delivered before they have been checked and be recognized as compliant.
- Procedures shall be set out for identifying causes of non-compliance, which make it possible to provide sustainable solutions that can be applied more widely to resolve the non-compliance and prevent it reoccurring.

These operations shall be recorded in the appropriate documents and be approved by Renault prior to being applied more widely.

- Track changes in the quality of products and assembly and removal services using inspection and audit indicators (incidents, complaints, etc.).

This tracking shall result in preventive or corrective actions; they shall be approved by Renault before being applied.

1.5 COMPLIANCE OF MESSAGES AND COLOURS

Visuals must comply with the official images contained in this document.

All shades have a 40% satin finish unless specified otherwise. Particular attention should be paid to complying with the colour code.

Compliance with the tolerances for the L.a.b. is required.

GENERAL TECHNICAL REQUIREMENTS

2.1.1 STANDARDS

The reference base to be followed for design and manufacturing shall, at the very least, be that required by Eurocode standards.

The regulations relating to the dimensioning of structures in force in each of the countries concerned shall be complied with taking climatic conditions into account.

The following obligations in terms of results must be met:

- Supported under their own weight, the equipment must appear perfectly horizontal and vertical.
- The parallel alignment of separate elements must be observed.
- Under normal wind conditions (Cf. NV65 and NF EN1991-1-4 (Eurocode 1)), the permissible bend between the fastening and the point most distant from the fastening (dimension «d») shall not exceed $d/100$.

2.1.2 CLIMATIC CONDITIONS

Wind loads to be considered for the design of structures shall be taken from the Eurocode 1 rules (EN 1991-1-3): zones 4 (28 m/s), roughness IIIb, force coefficient equal to 1.80. Any structure situated in an unfavorable geographical area with regard to this load case shall be subject to a special design basis in order to meet the applicable standards.

2.1.3 DESIGN RULES

2.1.3.1 ALUMINIUM STRUCTURES

Design rules for aluminium structures - most recent edition of DTU rules (currently, July 1976).
Applicable standard for the execution of structures: NF EN 1090-2 and Eurocode 9.

2.1.3.2 STEEL STRUCTURES

Design rules for steel structures CM 66 » - most recent edition.
Applicable standard for the execution of structures: EN 1093 and Eurocode 3.

2.1.3.3 RUBBER SUPPORT BLOCKS

The round support blocks are made by the service provider HET.
Standard applicable for the execution of the elements to be found in their official documents.

2.1.3.4 DESIGN CALCULATIONS FOR PLASTIC ELEMENTS

Adapt the CM 66 rules using a safety coefficient of 2 for the stresses.

2.1.4 MATERIALS

2.1.4.1 GENERAL REMARKS

The materials used shall all be first-choice materials suitable for their envisaged use and they shall be used in accordance with the rules of best industry practice for the profession and in compliance with the standards and regulations in force in France and in the Countries in which they are intended to be used.

The materials used shall not have any defect that is likely to compromise the durability of the structures. The equipment shall be easy to clean, maintain and service.

The materials shall be capable of withstanding harsh climatic conditions such as rain, snow, hail, condensation, dust and salt spray.

Operation must be guaranteed between - 20 and + 80 ° C.

GENERAL TECHNICAL REQUIREMENTS

2.1.4.2 STEELS

Steels shall be either «hot finished» as per NF EN 10210 or «cold finished» as per NF EN 10219-1 and 2. The quality of the steels shall be stated on the production drawings and it goes without saying that the mechanical properties of the different types of steels must be taken into account for stability calculations.

All elements shall be manufactured in a covered, sheltered location.

After machining, welding, drilling, notching, etc. the elements shall be prepared prior to anti-corrosion treatment: brushing of welds, careful deburring, cleaning, shot peening and sand blasting.

The anti-corrosion treatment shall be performed by hot galvanization of a minimum of 80 µm and shall provide fault-free protection for at least the period of the ten-year guarantee. No machining may be carried out once the parts have undergone anti-corrosion treatment.

All fasteners and hardware (including hinges) shall be made of 18/10 stainless steel (NFE 25.033).

2.1.4.3 ALUMINIUM

The reference standard is NF EN 573-1. Parts used in a supporting structure shall be chosen from the «6000» series. For parts which are not used in a supporting structure, the «1000» series shall be acceptable.

The alloys are to be weldable.

The parts shall be carefully deburred and the welds shall be brushed before any protective treatment.

The visible parts of equipment shall be treated by the application of paintwork performed according to a «Qualicoat»-type procedure.

2.1.4.4 RUBBER

The round support blocks are made by the service provider HET.

Applicable standard & technical characteristics for the execution of the elements to be found in their official documents.

2.1.4.5 PMMA

The PMMA shall meet at least the following characteristics:

· Opal white (values for a test piece of 3mm thick)	Flat parts machined «cast» PMMA	Flat parts unmachined «extruded» PMMA
· Tensile strength	> 75 MPa	> 70 MPa
· Bending strength	> 130 MPa	> 120 MPa
· Bending modulus	> 3,250 MPa	> 3,000 MPa
· Unnotched CHARPY impact test strength	> 12 MPa	>10 MPa
· Expansion	< 1 mm / 1 m / 10°C	<1 mm / 1 m / 10°C
· Light transmittance	> 50 %	>33 %

The thermoformed panels shall be made of white, light diffusing, extruded PMMA in compliance with the sheet manufacturer's heating parameters.

Where parts made of PMMA are more than 100 cm high, they shall be hung from the top by an adhesive PMMA cleat.

The thickness of the sheets shall be calculated in compliance with the tensile strength standards set out above.

GENERAL TECHNICAL REQUIREMENTS

2.1.4.6 POLYCARBONATE

The polycarbonate sheet shall meet at least the following characteristics:

- Uncoloured appearance
- Density > 1.2 g/cm³
- Tensile strength: 60 Mpa
- Expansion < 0.7 mm / 1 m / 10°C
- Light transmittance > 90%

2.1.4.6 EXPANDED FOAM

These following characteristics must be met:

- Material 9010 white PVC
- Density > 50 g/cm³
- UV-stabilized: 14 MPa
- Shore hardness D > 75
- Expansion < 1 mm / 1 m / 10°C

2.1.4.7 PAINT

Painted parts must have an even appearance across their entire surface.

Defects such as pores, fissures, grains of dust, runs or waves of paint shall not be tolerated.

Samples of painted rough parts shall be tested and accepted by Dacia, after having undergone the following tests performed by a certified body:

- Colour based on a LAB test with a MINOLTA 508 D colorimeter with D65 illuminant and the observer at 10° and specular component included (the tolerances in the CIELAB colour space are L +/- 1, a +/-1.5, b +/- 1.5).
- Gloss at 40 °: based on a test according to NF T 30064 standard.
- Gloss at 60 °: based on a test according to NF T 30064 standard
- Adhesion: resistance to peeling based on grid test. Class 1, as per P UW 150 1. NF T 30038 standard
- Colour fastness: QUV as per NF T 30036 after 200 hours of exposure.

Samples of each of the elements shall be supplied, upon request, to Dacia for inspection.

2.1.5 ELECTRICAL EQUIPMENT

Assemblies with electrical equipment shall comply with the essential safety requirements of the European Union. Within this framework, the supplier shall obtain a certificate (for each type of equipment) which must clearly state the compliance of the assemblies, and thus of the components, with:

- requirements relating to the safety and protection of users and all other persons (directive 73/23/EEC without any lower voltage threshold)
- requirements relating to electromagnetic compatibility (directive 89/336/EEC).

The rating plate on each item of equipment shall display the CE mark indicating compliance with these requirements.

The regulations relating to low-voltage signage in force in each of the countries concerned shall be complied with taking climatic conditions into account.

In addition, the following requirements shall be met:

Electrical equipment shall be compliant with the standards in force from the series NFC 15-100, NFC 20-010 and NFC 20-030, NFC 71, NFC 32 for France and the IEC 60364 international standard.

GENERAL TECHNICAL REQUIREMENTS

This concerns the following in particular:

- Category one electrical installations and low-voltage illuminated signage installations.
- The fire behaviour of electrical equipment and the degree of protection of enclosures,
- Flexible and rigid low-voltage cables.

In addition, the equipment shall comply regulations relating to the suppression of interference in inhabited areas and shall thus be delivered with interference suppression.

2.1.5.1 IP RATING

All the electrical equipment shall have a protection rating of at least IP 44-D.

2.1.5.2 PROTECTION AGAINST ELECTRIC SHOCK

All equipment shall be «class 1».

2.1.5.3 FASTENERS

The converters shall be placed in areas not subject to standing water.
The cables and sheaths shall be fastened to structures at 50 cm intervals.

2.1.5.4 CABLE ROUTING

Every cable or sheath passing through a metal part shall be routed through a cable gland.
Connection boxes.

An IP 44 sealed plastic connection box shall be provided at the inlet to each assembly. This box shall be equipped with a 5-input connection pin for 4 mm wiring.

All the connection boxes shall have the markings P1+P2+P3+T+N.

2.1.5.5 LEDs

The white LEDs used shall have the following characteristics:

- Lifetime: 50,000 hours for a loss of initial luminous flux of 50 % at the end of the period
- 5 year guarantee for operation 10 hours per day with a maximum loss of luminous flux of 20 %
- Operating temperature of LEDs: between - 20° C and +50 °C.
- Minimum protection index: IP 67
- The LEDs used must comply with the following international standards: IEC 62504 TS Ed. 1, IEC 61231, IEC 62560 Ed 1, IEC 62031 LED module safety, IEC 61347-2-13 LED

2.1.5.6 CONVERTERS

The power supply converters for the LEDs shall have the following characteristics:

- Wide power supply voltage range (100 to 300 volts)
- Reversible protection against increase in temperature and overload
- Protection against short-circuits with automatic restart
- Minimum protection index: IP 67
- Operation compliant with: EN 55015, EN 61000-3-2, EN 61547, EN 61558-2-17.

GENERAL TECHNICAL REQUIREMENTS

2.1.6 FASTENERS AND HARDWARE

All fasteners and hardware used shall be made of stainless steel (non-magnetizable).
Aluminium «pop» rivets are accepted as long as the steel rods are systematically removed.
For welding, the wires and electrodes are to be compliant with NF 81.830.

2.1.7 ANCHORING SYSTEMS AND FASTENINGS

The plinths for all equipments shall be completely removable without having to remove another element of the assembly. The plinths shall cover the attachment plates or fastenings. The attachment plates shall be easily accessible once the plinths have been removed.
For each of the assemblies which require a foundation block or fastening to a separate structure, the signmaker shall provide the elements necessary, as well as the conditions to be used to make design calculations for these elements (wind conditions and design calculation methods).

2.1.8 IDENTIFICATION PLATE

Each finished product shall be marked with a metal identification plate on the structure which shall show at least the following information:

- Name of the signmaker
- Product code and batch
- Month and year of manufacturing
- The CE Marking if it is illuminated.

2.1.9 STORAGE

The finished products shall be stored in a dry and well-ventilated location.
Dacia inspectors shall be able to have access to them at any time.

GENERAL TECHNICAL REQUIREMENTS

2.2. GUARANTEES

The suppliers undertake to offer the guarantee conditions below for their products:

- 2 year guarantee on the installation against defects and faulty workmanship,
- 5 year guarantee on the electrical equipment including the LEDs and converters,
- 5 year guarantee on the adhesive elements,
- 5 year guarantee on digital printing (anti UV treatment),
- 5 year guarantee on workshop-lacquered sheet metal,
- 5 year guarantee on the chrome-plated emblems,
- 7 year guarantee on sheet metal and profiles pre-lacquered by the aluminium manufacturer,
- 10 year guarantee on the internal structures,
- 10 year guarantee on the PMMA acrylic panels.

DOCUMENTARY SYSTEM

SEVERAL DOCUMENTS RESPOND TO THE ISSUES THE DEPLOYMENT OF THE NEW INTERIOR RETAIL CONCEPT

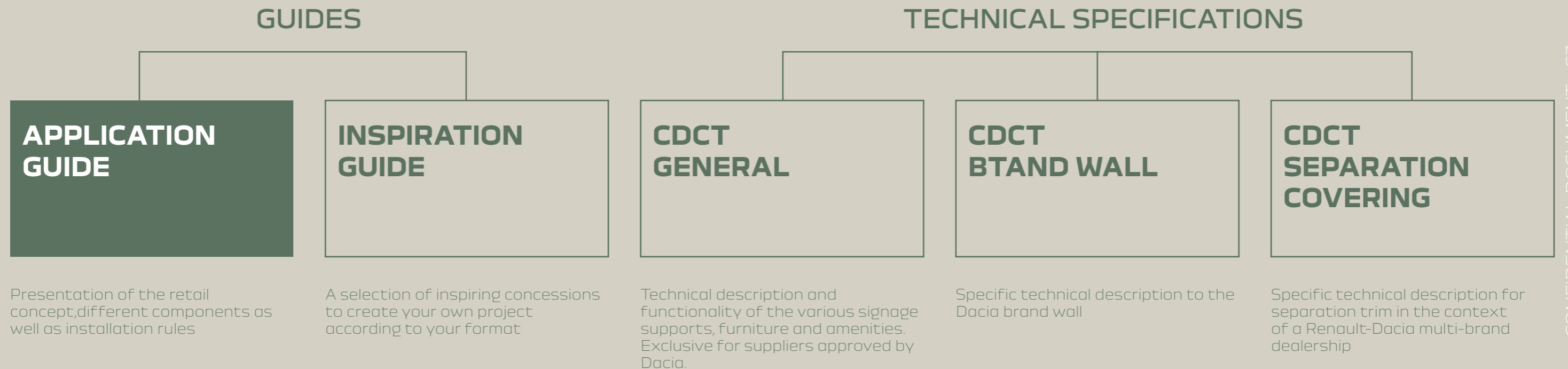

The source files as well as all the guides can be downloaded on the Brand Stores Platform <https://brandstores.renault.com>